

TMI-2 Special Sessions

**1982
ANS Winter Meeting**

Washington, D.C.

Published by EG&G Idaho, Inc.
for the U.S. Department of Energy
under contract no.
DE-AC07-76ID01570

DISCLAIMER

This book was prepared as an account of work sponsored by an agency of the United States Government. Neither the United States Government nor any agency thereof, nor any of their employees, makes any warranty, express or implied, or assumes any legal liability or responsibility for the accuracy, completeness, or usefulness of any information, apparatus, product or process disclosed, or represents that its use would not infringe privately owned rights. References herein to any specific commercial product, process, or service by trade name, trademark, manufacturer, or otherwise, does not necessarily constitute or imply its endorsement, recommendation, or favoring by the United States Government or any agency thereof. The views and opinions of authors expressed herein do not necessarily state or reflect those of the United States Government or any agency thereof.

FOREWORD

The American Nuclear Society 1982 Annual Winter Meeting included four Special Sessions on the research and development work arising from the TMI-2 accident of March 28, 1979. Research and development continue to yield data on the mechanisms, consequences, and implications of the accident sequence which occurred nearly four years ago. Paper summaries and slide presentations included in the following pages offer an overview of the material discussed in the ANS Winter Meeting TMI-2 Special Sessions. These summaries are presented in the order in which they appeared in the September Preliminary Meeting Schedule.

This volume includes the material available at the time of publication in late October 1982. The ANS Meeting was conducted in Washington, DC during the week of November 14, 1982.

CONTENTS

FOREWORD

TMI-2 REGULATORY PERSPECTIVES AND CORE REMOVAL OPERATIONS

TMI-2 Reactor Vessel Head Removal and Damaged Core Removal Planning:
J. A. Logan (EG&G Idaho, Inc.), C. W. Hultman (Bechtel National),
T. J. Lewis (EG&G Idaho, Inc.).

Axial Power Shaping Rod Insertion Test:
K. Parlee (United Engineers & Constructors), J. A. Wiessburg (EG&G
Idaho, Inc.), W. Austin (GPU Nuclear), G. Carter (B&W).

TMI-2 "Quick Look" Examination:
W. A. Franz (EG&G Idaho, Inc.), R. L. Rider (Bechtel Northern),
W. A. Austin (GPU Nuclear), N. Cole (MPR Assoc.).

TMI-2 Core Examination: First Results:
D. E. Owen, M. R. Martin (EG&G Idaho, Inc.).

An Overview of the TMI-2 Core Examination Program:
K. C. Sumpter (EG&G Idaho), K. A. Trickett, E. Feinauer (DOE-Idaho
Operations Office), D. E. Owen, M. R. Martin (EG&G Idaho).

TMI-2 INSTRUMENTATION AND MECHANICAL EQUIPMENT SURVIVABILITY

The Instrumentation and Electrical Program at TMI-2:
W. F. Schwarz (EG&G Idaho, Inc.).

TMI-2 SPND and Thermocouple Data Analysis:
M. E. Yancey (EG&G Idaho, Inc.).

In-Containment Radiation Monitoring at TMI-2:
M. B. Murphy (Sandia National Laboratory).

Preliminary Examination of MINAC for TMI-2 Debris Examination:
M. E. Lapidés (Electric Power Research Institute).

Thermal Analysis of the TMI-2 Primary Pressure Boundary and Potential
Impact on Requalification Plans:
S. W. Tagart, Jr. (Electric Power Research Institute), K. E. Moore
(B&W).

Investigation of Hydrogen Burn Damage in the TMI-2 Reactor Building:
N. J. Alvares, D. G. Beason (Lawrence Livermore National Laboratory),
G. R. Eidam, D. L. Reeder (EG&G Idaho, Inc.).

Analysis of the TMI-2 Hydrogen Burn:
J. O. Henrie (Richland Hanford Operations), A. K. Postma (Benton City
Technology).

TMI-2 FISSION PRODUCT CHARACTERIZATION AND DECONTAMINATION METHODS

Characterization of Fission Product Deposition in the TMI-2 Reactor Coolant and Auxiliary Systems:

Jack A. Daniel (SAI, Rockville), James C. Cunnane (Battelle Columbus Laboratories).

Fission Product Transfer in the TMI-2 Purification System:

T. E. Cox (EG&G Idaho, Inc.).

Analysis of TMI-2 Samples Using the Molecular Optical Laser Examiner:

J. E. Doyle, J. L. Alvarez (EG&G Idaho, Inc.).

Preliminary Results of the TMI-2 Radioactive Iodine Mass Balance Study:

C. A. Pelletier (SAI, Rockville), T. E. Cox, D. L. Reeder (EG&G Idaho, Inc.), P. G. Vollique, C. O. Thomas (SAI, Rockville).

Dose Reduction and Contamination Control in the TMI-2 Reactor Building:

G. R. Eidam (EG&G Idaho, Inc.), D. W. Leigh (Bechtel National).

Surface Deposition Measurements of TMI-2 Gross Decontamination Experiment:

C. V. McIsaac, D. C. Hetzer (EG&G Idaho, Inc.).

Evaluation of Nonchemical Decontamination for TMI-2 RCS Application:

H. R. Gardner (Quadrex, Richland), R. P. Allen (Pacific Northwest Laboratory), L. M. Polentz (Quadrex, Richland), W. E. Skiens (Pacific Northwest Laboratory), G. A. Wolf (Quadrex, Richland), L. E. Anderson (Electric Power Research Institute).

TMI-2 WASTE MANAGEMENT

Overview and Update on Waste Management Issues at TMI-2:

R. S. Daniels (Bechtel National), T. W. McIntosh (DOE-HQ), J. K. Reilly, (DOE-Idaho TMI).

Special Handling Requirements for Highly Loaded Organic Resins:

R. E. Ogle, J. M. Bower (EG&G Idaho, Inc.), T. E. Rekart (GPU Nuclear).

Research and Disposition of Highly Loaded Organic Resins:

R. C. Schmitt, K. C. Sumpter (EG&G Idaho, Inc.).

High Integrity Container for High-Specific Activity Wastes:

R. L. Chapman (EG&G Idaho, Inc.), R. T. Haelsing (Nuclear Packaging, Inc.).

TMI-2 Reactor Building Sump Water Level Measurements and Removal:

Ronald H. Greenwood (GPU Nuclear).

Zeolite Processing of the TMI-2 Reactor Building Sump and Reactor Coolant System:

K. J. Hofstetter, C. G. Hitz (GPU Nuclear).

Controls of Radiolytic Gases in Liners of Radioactive Zeolites:
J. Greenborg (GPU Nuclear), J. O. Henrie (Richland Hanford
Operations), G. J. Quinn (EG&G Idaho, Inc.).

TMI-2 REGULATORY PERSPECTIVES
AND CORE REMOVAL OPERATIONS

1 2 3 4 5 6 7 8 9 10 11 12 13 14 15 16 17 18 19 20 21 22 23 24 25 26 27 28 29 30 31 32 33 34 35 36 37 38 39 40 41 42 43 44 45 46 47 48 49 50 51 52 53 54 55 56 57 58 59 60 61 62 63 64 65 66 67 68 69 70 71 72 73 74 75 76 77 78 79 80 81 82 83 84 85 86 87 88 89 90 91 92 93 94 95 96 97 98 99 100

TMI-2 REACTOR VESSEL HEAD REMOVAL
AND

DAMAGED CORE REMOVAL PLANNING:

J. A. Logan (EG&G Idaho, Inc.), C. W. Hultman (Bechtel National),
T. J. Lewis (EG&G Idaho, Inc.)

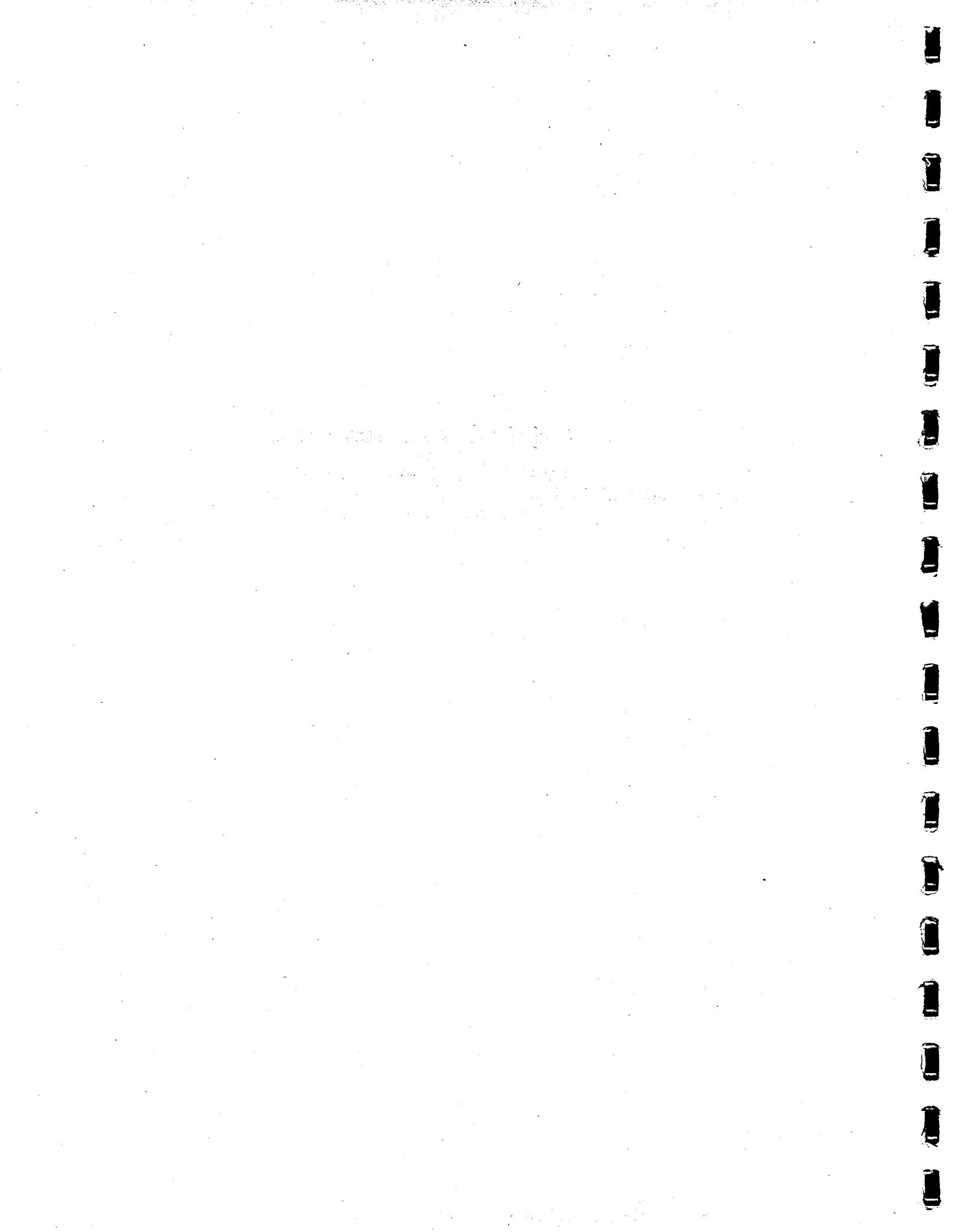

TMI-2 REACTOR VESSEL HEAD REMOVAL AND DAMAGED
CORE REMOVAL PLANNING*

J. A. Logan, EG&G Idaho, Inc.

C. W. Hultman, Bechtel National Corp.

T. J. Lewis, EG&G Idaho, Inc.

Major milestones in the cleanup and recovery effort at TMI-2 will be the removal of the reactor vessel closure head, plenum, and damaged core fuel material. The data collected during these operations will provide the nuclear power industry with valuable information on the effects of high temperature-dissociated coolant on fuel cladding, fuel materials, fuel support structural materials, neutron absorber material, and other materials used in reactor structural support components and drive mechanisms. In addition, examination of these materials will be used to determine accident time-temperature histories in various regions of the core.

After conducting dose reduction and decontamination activities, the first operations leading to reactor vessel head, plenum, and core removal were conducted in June and July 1982. These operations included Axial Power Shaping Rod (APSR) insertion tests, and "Quick Look" or closed circuit television (CCTV) viewing of the upper reactor vessel internals. These operations are reported in other papers presented at this meeting.

Other activities in recent months include the formation of task groups to determine the best approaches for head, plenum, and core removal. With regard to head removal, the principal task group will devise a method to accomplish safe head removal as soon as practical in a manner which will not impede (and if possible, will enhance) the subsequent operations of plenum removal and core removal.

* Work supported by the U.S. Department of Energy, Assistant Secretary for Nuclear Energy, Office of Coordination and Special Projects, under DOE Contract No. DE-AC07-76ID01570.

The recent activities involved in the "Quick Look" have provided information helpful for planning these operations. During the "Quick Look," coolant samples taken within the reactor vessel above the core showed that the reactor coolant in this location has characteristics equivalent to those in coolant routinely taken from the Reactor Coolant System. The samples have a concentration of about 3800 ppm, turbidity of 14 NTU units, and specific radioactivity 10 μ ci/ml. About one fourth of the specific radioactivity is due to cesium-137 (a significant gamma emitter), while the remainder is due to strontium-90, a beta emitter not affecting personnel as much as the cesium activity. Since reactor coolant system specific activity due to cesium has shown a continuous decrease due to use of the Submerged Demineralizer System (which is continuing), it is probable that the reactor coolant specific activity will be lower in cesium activity when reactor vessel head removal operations commence than it is at present.

In addition, "Quick Look" examinations have thus far disclosed no damage to the plenum and no material adhering to it other than a thin layer of finely divided particulates. These indications, along with the above-mentioned decreasing reactor coolant specific activity, enhance the prospects for relatively uncomplicated head and plenum removal.

The head removal task group is evaluating alternate methods for head removal, i.e. whether head removal should be undertaken dry (that is, without flooding part or all of the fuel handling canal prior to or during head removal), or wet. Some concerns associated with dry head removal arise from the fact that the top of the plenum (a 14-foot diameter structure about 10 feet tall) extends about one foot above the reactor vessel bolting flange, and little is now known about the quantity of fuel debris that may be located on this portion of the plenum. Thus, unless advance actions are taken to determine the quantity of such fuel deposits and to remove them, the possibility exists of high radiation intensity in

the vicinity of the reactor vessel if the head were lifted dry, and a potential would exist for undesirably high radiation levels of airborne particulate radioactivity.

The attractiveness of dry head removal arises from its relatively modest equipment fabrication and preparation requirements. The requirements can be satisfied without constructing an airlock outside the 23-foot diameter equipment hatch in the wall of the reactor containment building to permit large equipment introduction.

Wet removal of the head (or provision of backup wet removal capability) would require establishing capability for flooding the entire fuel handling canal, or at least the portion in the vicinity of the reactor vessel, to a depth of several feet above the reactor vessel. This flooding would suppress local area radiation and airborne particulate activity during and after head removal, and would provide capability for coping with the water-borne contamination resulting from head removal. Most wet removal scenarios require fabrication and installation of equipment taking six months to a year to accomplish, and construction of an airlock outside the equipment hatch to provide an entry pathway for the large equipment involved. One compensating aspect of the equipment requirements and associated airlock construction requirements for wet removal capability for head lift is that similar equipment and construction will probably be necessary to support subsequent plenum and core removal operations.

Follow-up "Quick Look" activities, together with on-going task group efforts, will soon lead to appropriate decisions as to head, plenum, and core removal methods, and associated equipment, systems, and facilities to be provided for those efforts.

Faint, illegible text covering the majority of the page, possibly bleed-through from the reverse side.



TMI-2

Reactor Vessel Head Removal and Damaged Core Removal Planning

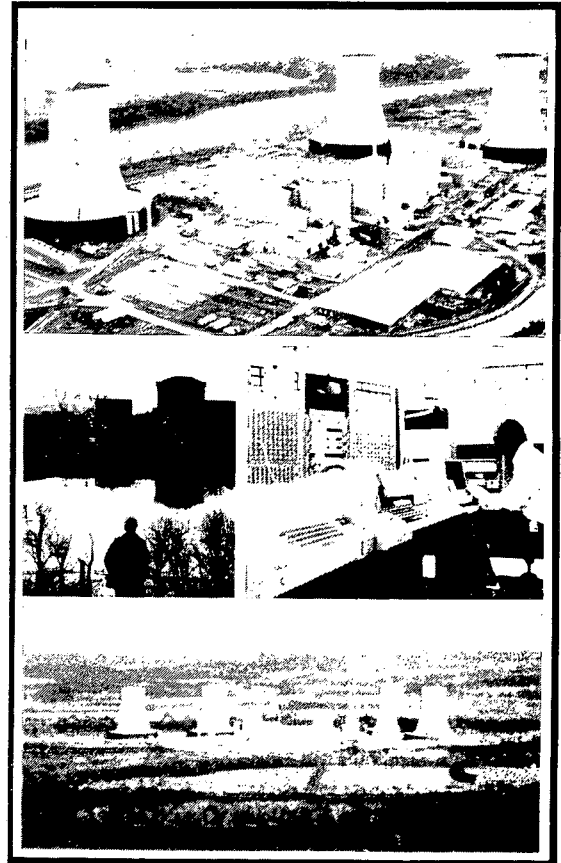

Returning the TMI-2 Plant to Safe Conditions

- Reactor vessel head removal
- Plenum assembly removal
- Damaged core, fuel, and debris removal

Head Removal Requirements

- Refurbish and requalify polar crane
- Characterize underhead radiation and debris
- Decontaminate pathways and work areas
- Develop procedures for contamination control
- Prepare for contingency canal flooding
- Develop equipment

S2 4023

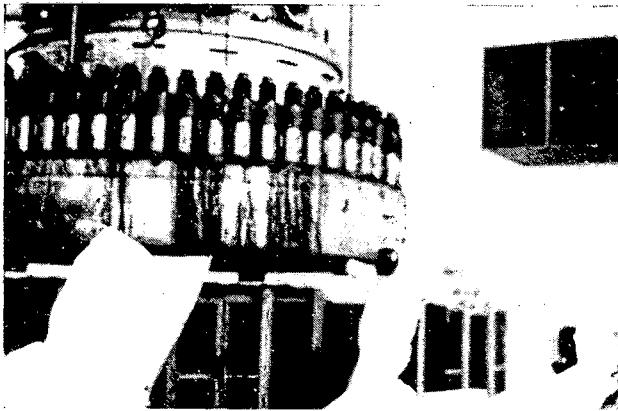

**Reactor Vessel
Head
Removal**

S2 4022

Head Removal Status

- Reference plan developed
- Polar crane inspection complete
- Underhead characterization engineering complete
- Pathway decontamination continuing
- Head removal equipment ordered
- All but 3 of 69 control rod leadscrews uncoupled

S2 4024

Reference Plan Developed

- Dry head removal with contingency flooding ability
- Area containment by “tenting”
- Head removal via “bag out” method
- Vessel isolation following head removal

S2 4025

Contamination Control During Head Removal

- Canal area “tented”
 - Constant air inflow and exhaust through HEPA filters
- Head lifted through “bag out” procedure
 - Largest ever performed
- Workers protected with “shadow shields”
- Storage stand shielded with portable water tanks
- Vessel isolated using
 - Partially flooded plenum indexing feature
 - Cover with access ports

S2 4027

Head Removal Preparations

- Decontaminate pathway and work area
 - To relax protective clothing requirements
 - To reduce heat stress and allow longer stay times
- Prepare for canal flooding
 - Long-term sealing and alternate flood methods needed
- Uncouple remaining 3 control rod leadscrews
- Make normal head lift preparations

S2 4026

Polar Crane Plans

- **Refurbishment**
 - Bridge, trolley, main hoist, temporary power supply
- **Requalification**
 - Will be 170 tons per ANSI B30.2 Para 2-2.2.2
- **Exceptions**
 - Load test to 195 tons instead of required 212 tons

S2 4033

Polar Crane Status

- **Inspection**
 - Structurally sound with no major problems
- **Decontamination**
 - Low pressure spray complete
 - Handwipe with detergents ongoing

S2 4034



Plenum Assembly Removal

S2 4028

Plenum Assembly Removal Requirements

- **Inspect plenum**
 - **Binding at close tolerances**
 - **Core materials stuck to upper grid**
 - **Loose debris**
- **Insert or remove remaining APSRs**
- **Eject stuck core materials from upper grid**
- **Provide tooling**
- **Provide storage enclosure**
- **Attempt trial lift**

S2 4029

Plenum and Fuel Removal Status

- Reference problem definition and conceptual design developed
- Removal system technical specifications developed
- Preliminary plenum removal plan developed
- Conceptual design of defueling test assembly for training and equipment checkout developed

S2 4032

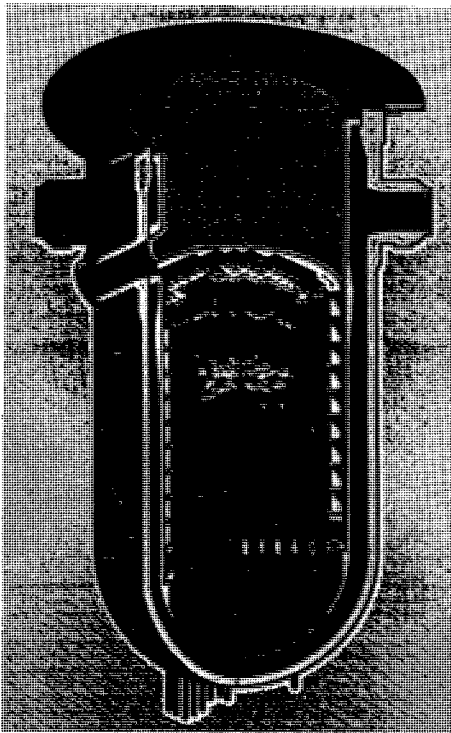

Core, Fuel, and Debris Removal

S2 4030

Fuel and Core Debris Removal Requirements

- Characterize debris bed
- Flood canal
 - Control turbidity and suspended and dissolved activity
- Provide tooling
- Modify spent fuel pool and racks
- Provide interim storage and shipping canisters
- Ensure equipment hatch accessibility

S2 4031

AXIAL POWER SHAPING ROD INSERTION TEST:
K. Parlee (United Engineers & Constructors),
J. A. Wiessburg (EG&G Idaho, Inc.), W. Austin (GPU Nuclear),
G. Carter (B&W)



AXIAL POWER SHAPING ROD INSERTION TEST*

K. Parlee, United Engineers and Constructors, Inc.

J. Weissburg, EG&G Idaho, Inc.

W. Austin, General Public Utilities Nuclear Corp.

G. Carter, Babcock & Wilcox

Test

On 23-25 June 1982 the eight TMI Unit 2 Axial Power Shaping Rods (APSRs) underwent insertion testing to determine the mechanical motion of the drive and rod systems. The purpose of the test was twofold:

1. To gain insight into the extent of core and upper plenum damage from knowing the ability to move some or all of the APSRs. This early insight will be factored into plans for subsequent inspections, head and upper plenum removal, and core removal.
2. To insert as many of the APSRs into the core as possible, since prior to head removal it is necessary to decouple the APSR leadscrews, which is most easily accomplished with assemblies fully supported.

The test involved an attempt to insert eight APSRs the remaining distance of their travel into the Unit 2 core. The distance from full APSR removal (100%) to full rod insertion (0%) is approximately 350 cm. Before testing, all the rods were at 25%, with approximately 90 cm of rod not inserted into the core. During testing, the acoustic emissions of the rotary drive mechanisms were recorded to verify the motion of the drive and rod systems.

* Work supported by the U.S. Department of Energy, Assistant Secretary for Nuclear Energy, Office of Coordination and Special Projects, under DOE Contract No. DE-AC07-76ID01570.

Possible damage to the integral position indication systems required confirmation by the supporting data system. The eight rods were inserted one at a time, very slowly compared to the standard rate of insertion.

The procedure called for withdrawing each assembly less than 1 cm and then inserting it fully into the core. Motion was monitored by detecting pole slippage, either acoustically or electrically, and by the individual position indicators. Pole slippage occurs when the electrical field in the stator rotates but the mechanism rotor does not stay in synchronism, either lagging or remaining stationary. The portable service power supply was used to run each APSR mechanism, one at a time.

Pretest Support

The test was supported by the results of two prior tests: (a) static testing of each APSR stator's electrical properties, measuring insulation and winding resistance, and capacitance and inductance, (b) and motion testing by EG&G Idaho and B&W at the Diamond Power Test Facility in Lancaster, Ohio.

The static tests indicated that the stators were electrically operational. The motion tests (a) confirmed that leadscrew motion can be monitored using pole slippage, (b) confirmed that latching could be determined acoustically, (c) measured mechanism forces transmitted to the leadscrew as a function of stator power, (d) measured stator heat-up rates without cooling water, (e) measured leadscrew motion under latching conditions, (f) confirmed the ability to use a portable power supply to provide the necessary experimental control, (g) determined the effect that water in the housing, or the absence of water, has on mechanism performance.

Test Procedure

Testing of individual APSRs followed a basic sequence. First, using a portable service power supply, the latching current was applied to the selected APSR mechanism. Confirmation of latching was obtained acoustically by means of a pickup attached to the mechanism.

Next, operating in the single-step mode, attempts were made to move the control assembly a total of 0.5 cm outward. During each step, electrical and acoustic outputs were monitored for evidence of pole slipping, i.e., a stuck assembly. The current selected for this and subsequent operations varied; the force applied by the drive line varied from about 225 to a maximum of 630 kg. After moving or attempting to move the assembly outward, inward motion was attempted, first in the single-step mode, monitoring electrically and acoustically for evidence of pole slipping.

Finally, if the initial inward motion was successful, the assembly was moved inward in the "jog" mode, again monitoring for pole slipping. Confirmation of motion was obtained from the absolute position indication system. When the assembly reached the bottom of its travel, its position was confirmed by both the absolute rod bottom indication and by evidence of pole slipping. When sticking occurred at any juncture of this sequence, controlled increases in force (current) were made, up to the maximum 630 kg force.

Summary of Results

Insertions were performed under closely controlled conditions with rod motion responses ranging from a maximum of 0%, indicating full rod insertion, to a minimum of 25%, indicating that approximately 90 cm of the rod was not inserted into the core. Two rods were fully inserted. Two rods were inserted to within 20 cm of the full "down" position, the distance out approximately equal to the length of a close-fitting dashpot motion snubber for the rod

assemblies. Two rods moved in less than 20 cm. And two did not move in at all, although the drive rotor assembly did latch and unlatch properly, and showed minor rotational movement before reaching maximum force on the nonmovable leadscrews. The configuration of maximum to minimum insertion was not regular. Further study may show some relation between leadscrew travel and apparent damage indicated by other previously gathered data, such as thermocouple damage and other instrument integrity.

Evaluation

The test was totally successful, in that all data channels worked properly and all expected events were clearly recorded. The effort, as a recovery step, was totally successful, since each rod was either completely inserted, or driven in until supported by a resistance greater than the downward force needed to perform the rod-leadscrew joint uncoupling. The configuration restoration was partially successful, since the travel for all eight rods was equal to about half the total cumulative distance the rods were extended out from the core prior to the test.

TMI-2

Axial Power Shaping Rod Insertion Test

R.D. Meininger
Senior Project Engineer
TMI Technical Support

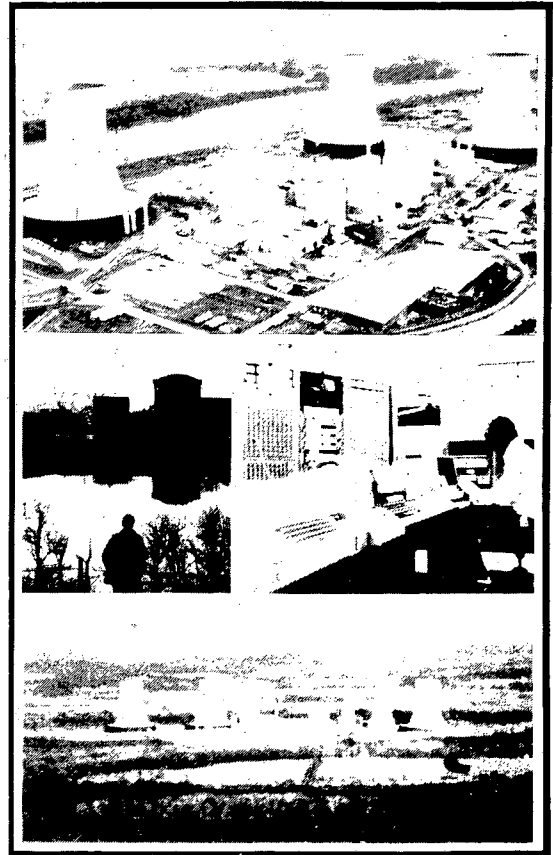

TMI-2 Reactor Vessel

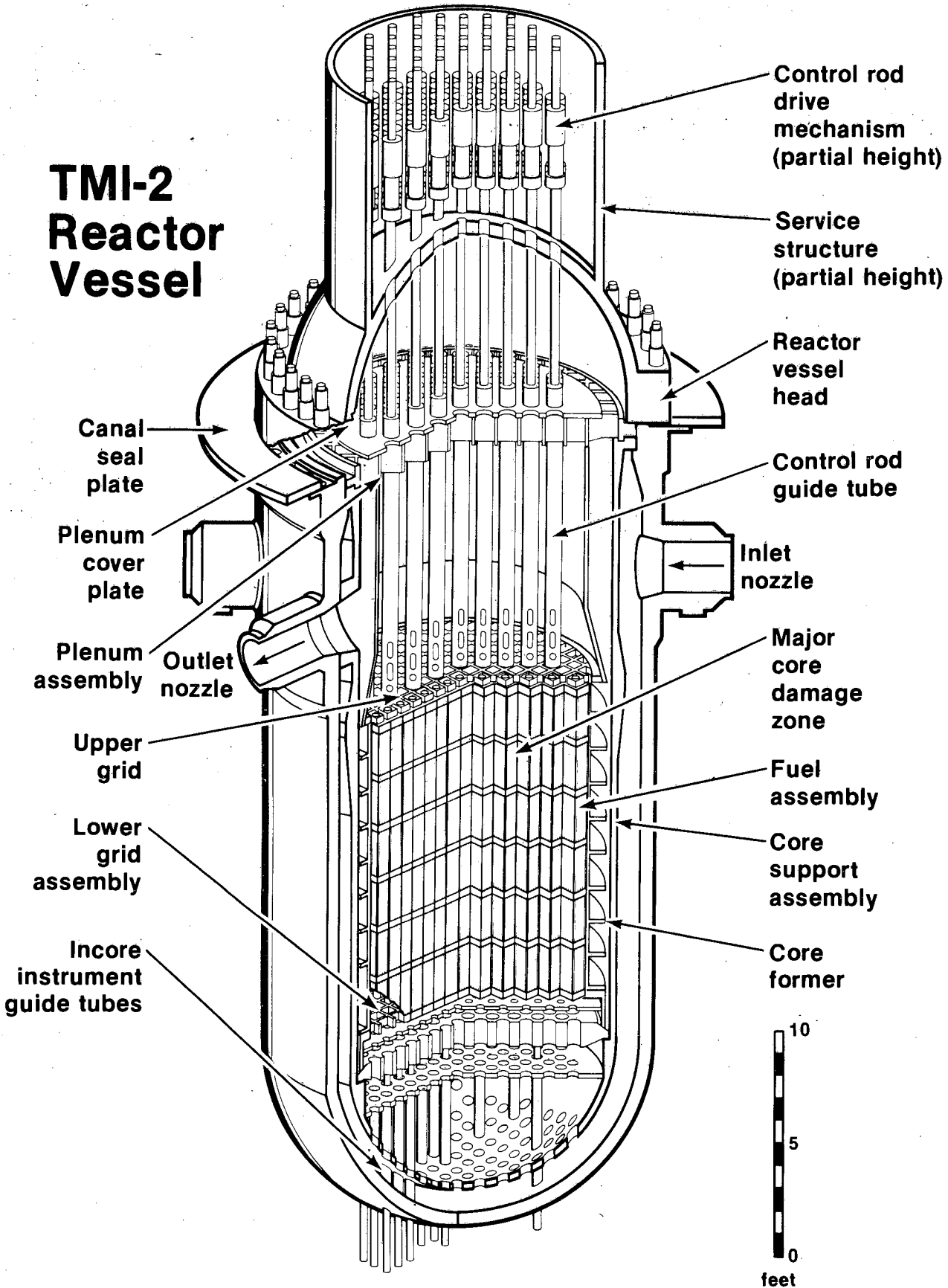

Control and Shaping Rod Locations

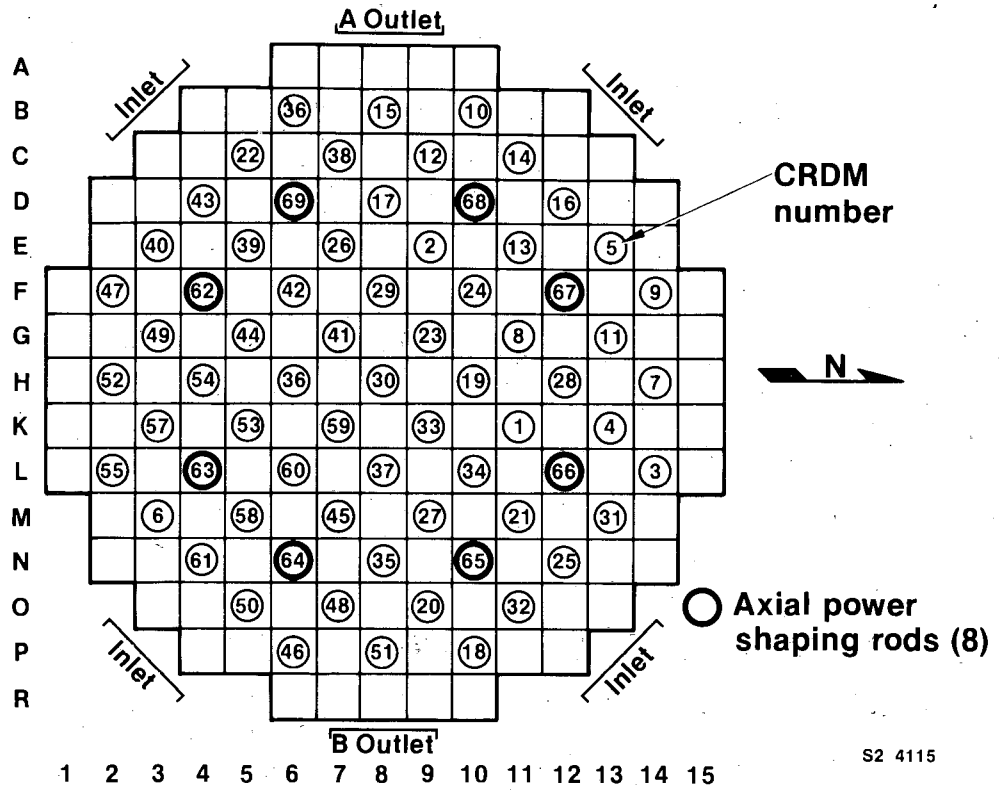

S2 4115

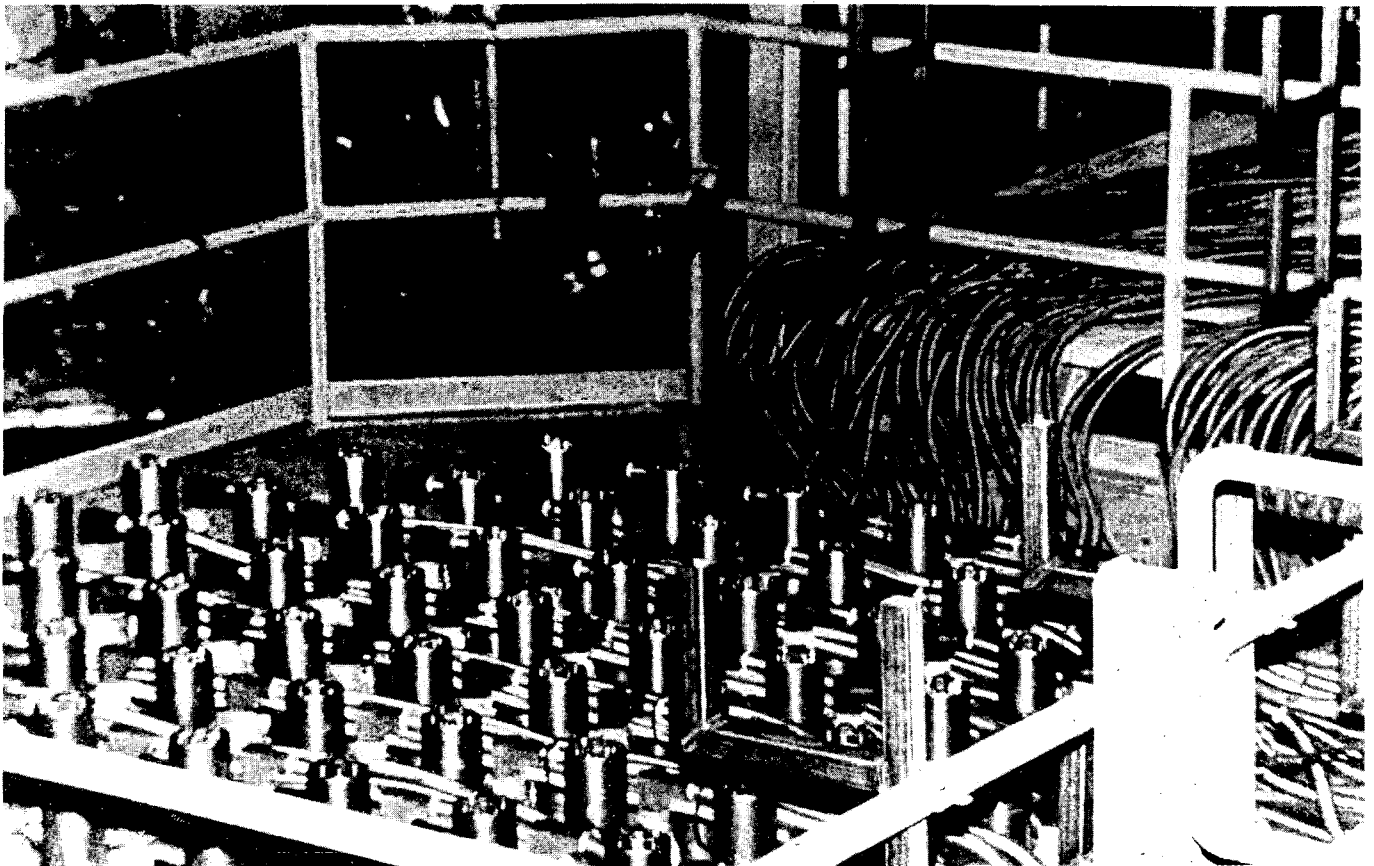

APSR Insertion Test Objectives:

- **To assess extent of core and upper plenum damage, needed to plan:**
 - Other inspections
 - Head/upper plenum removal
 - Core removal
- **To insert APSR's to "hard stop" position, needed to uncouple leadscrews for head removal**

S2 4116

APSR Insertion Test

- **Considerations:**
 - First deliberate disturbance in damaged core
 - Potential for reactivity increase
- **Consequent requirements:**
 - Power one APSR at a time
 - Rigorous procedure, detailed review and approval
 - Reactivity monitoring
 - Licensed operator in absolute control
 - Characterize APSR behavior before TMI-2 insertion test

S2 4117

Preparatory Testing

- In Situ testing, TMI-2:
 - To determine electrical condition
 - To acquire data for rotor position prediction
- Motion testing, Diamond Power:
 - To characterize operation
 - Electrically
 - Acoustically
 - In air
 - In water
 - To confirm rotor position predictability

S2 4118

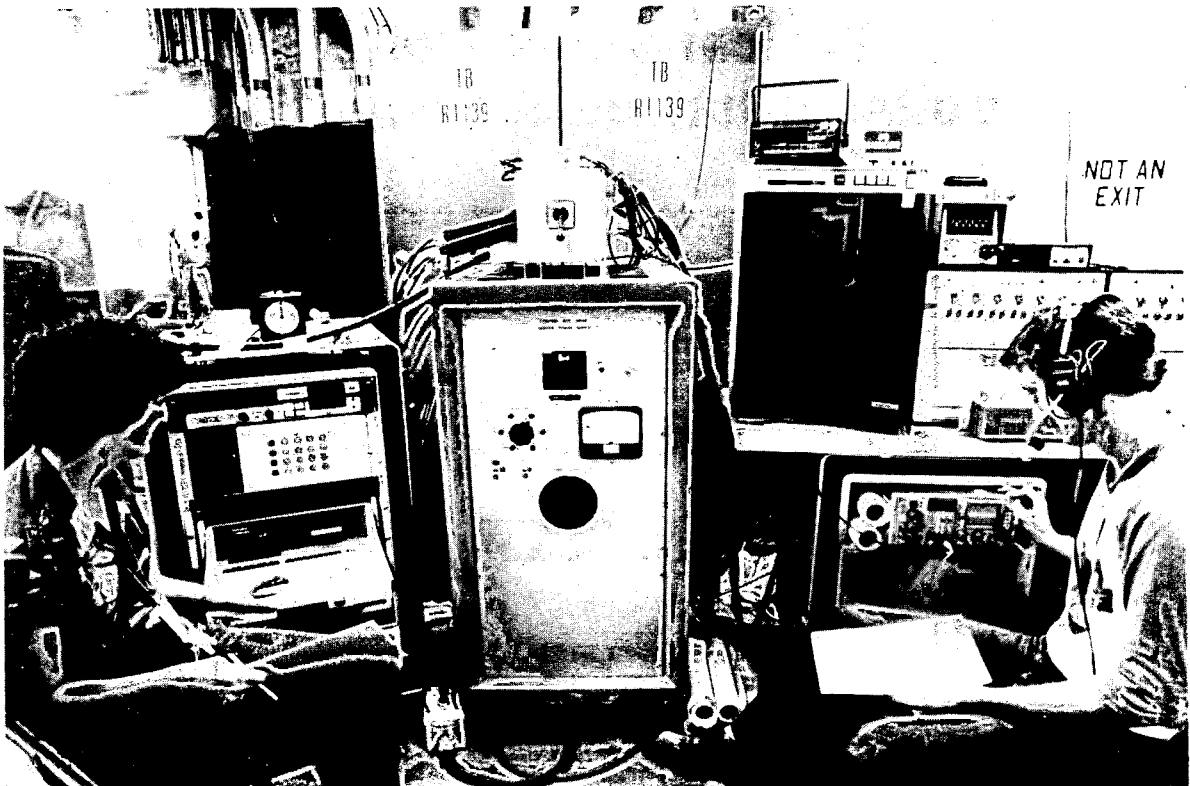

Preparatory Testing: Data Acquired

- Stepping motor waveforms
 - Stator voltage
 - Stator current
- Acoustic signatures
 - Operating noises, like latch, pole slip
- Stator temperature, heat-up rate
- Absolute position

S2 4119

Typical Stator Coil Voltage/Current Waveforms

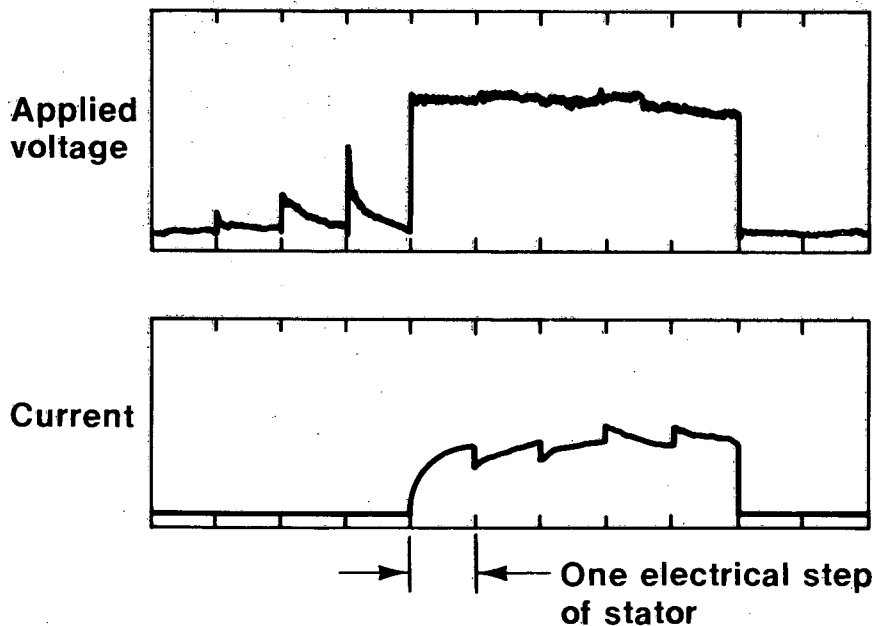

S2 4120

Preparatory Testing: Results

- In Situ tests:
 - All TMI-2 CRDM's electrically functional
 - Rotor positions predicted
- Motion tests:
 - Electrical and acoustical responses defined for
 - Latch/unlatch, pole slip
 - Motor operation, force as f(power)
 - Motor noises, impacts
 - Rotor position is predictable
 - Uncooled stator heatup rate acceptable
 - Solid basis for TMI-2 insertion test procedure

S2 4121

TMI-2 Insertion Test Results

APSR No:	Initial position, % *	Final position	
		% *	Inches * (approx.)
62	26	5	7
63	25	19	27
64	25	25	36
65	25	0	0
66	25	4	6
67	26	1	1
68	25	23	33
69	26	26	37

* Means % or inches of withdrawal, where 100% \cong 144 inches. APSR's were in pre-accident positions.

S2 4122

TMI-2 Insertion Test Observations

- Four APSR's moved 6'' or less
 - Indication: Physical damage/binding
- The other four APSR's moved 30'' or more
 - Indications: Little physical damage/binding, or, extensive physical damage, up to total absence of poison rods and guide tubes.

S2 4123

Estimate of Damaged Assemblies Using 1979 Core T/C Data (°F)

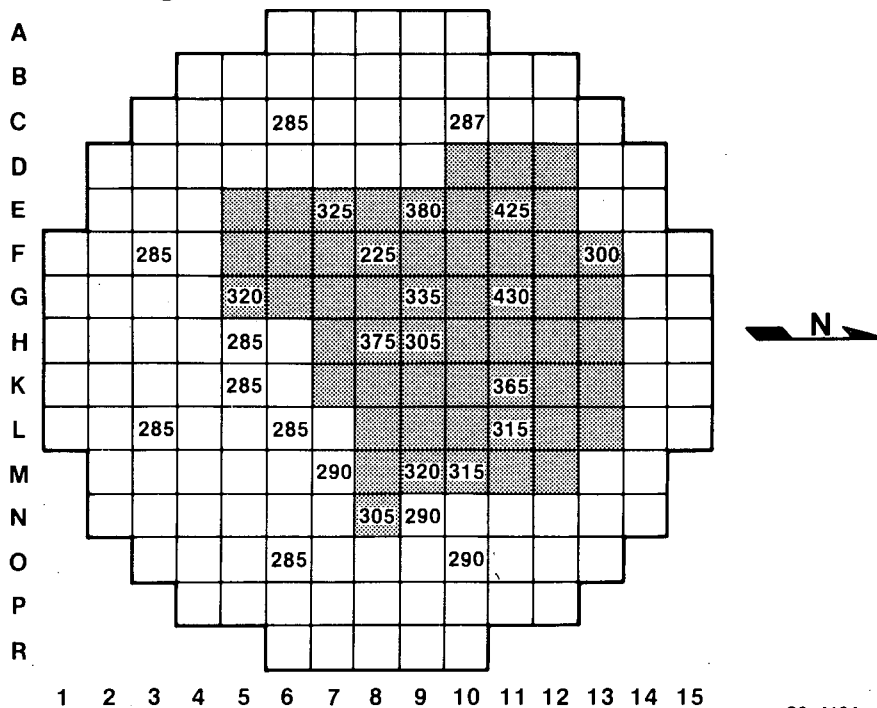

S2 4124

APSR Percent Withdrawn After Dynamic In Situ Test

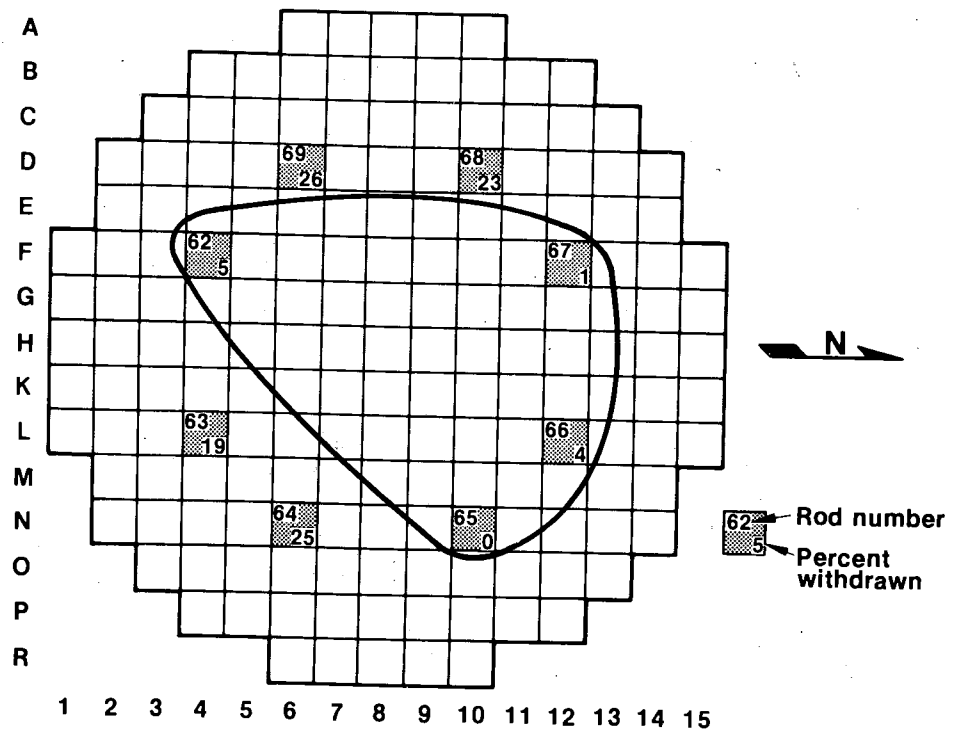

S2 4125

Conclusions

- From APSR insertion test only:
 - Uncoupling of all APSR's should be possible
 - All APSR drives survived, remained operable
- From APSR + in-core instrument test data:
 - Upper plenum is relatively undamaged
 - Large void in upper core is suspected

1941

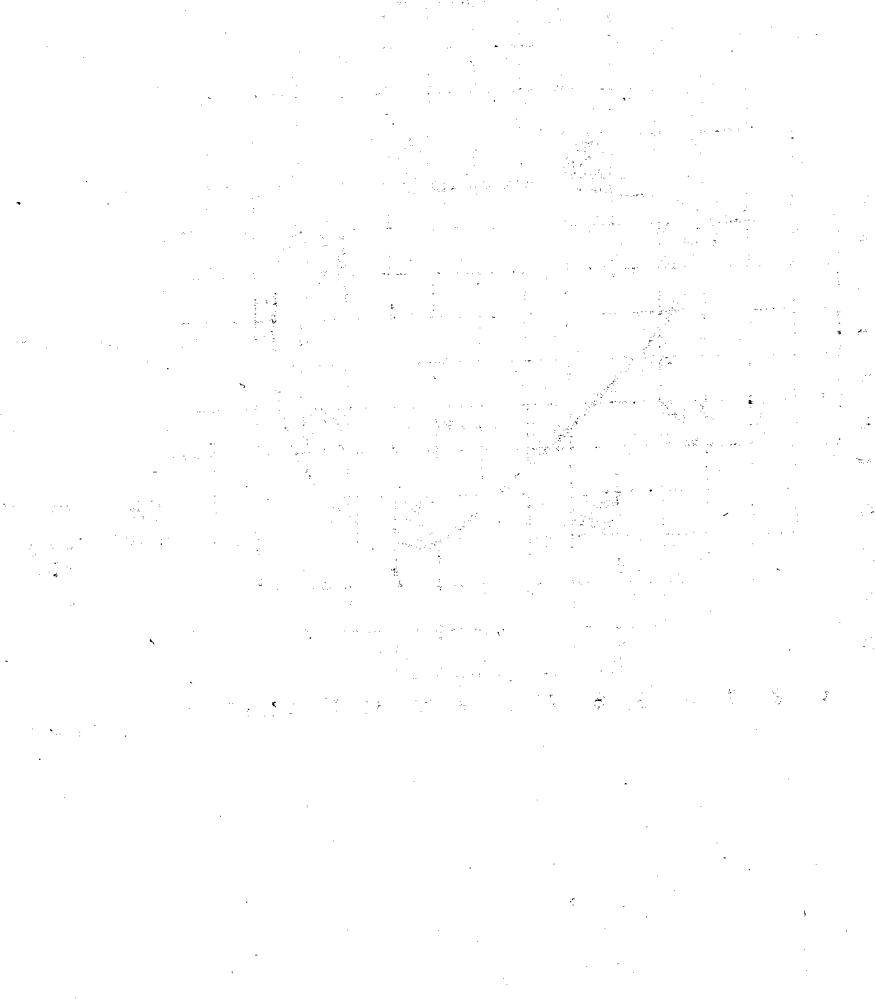

1942

1943

1944



TMI-2 "QUICK LOOK" EXAMINATION:
W. A. Franz (EG&G Idaho, Inc.), R. L. Rider (Bechtel Northern),
W. A. Austin (GPU Nuclear), N. Cole (MPR Assoc.)

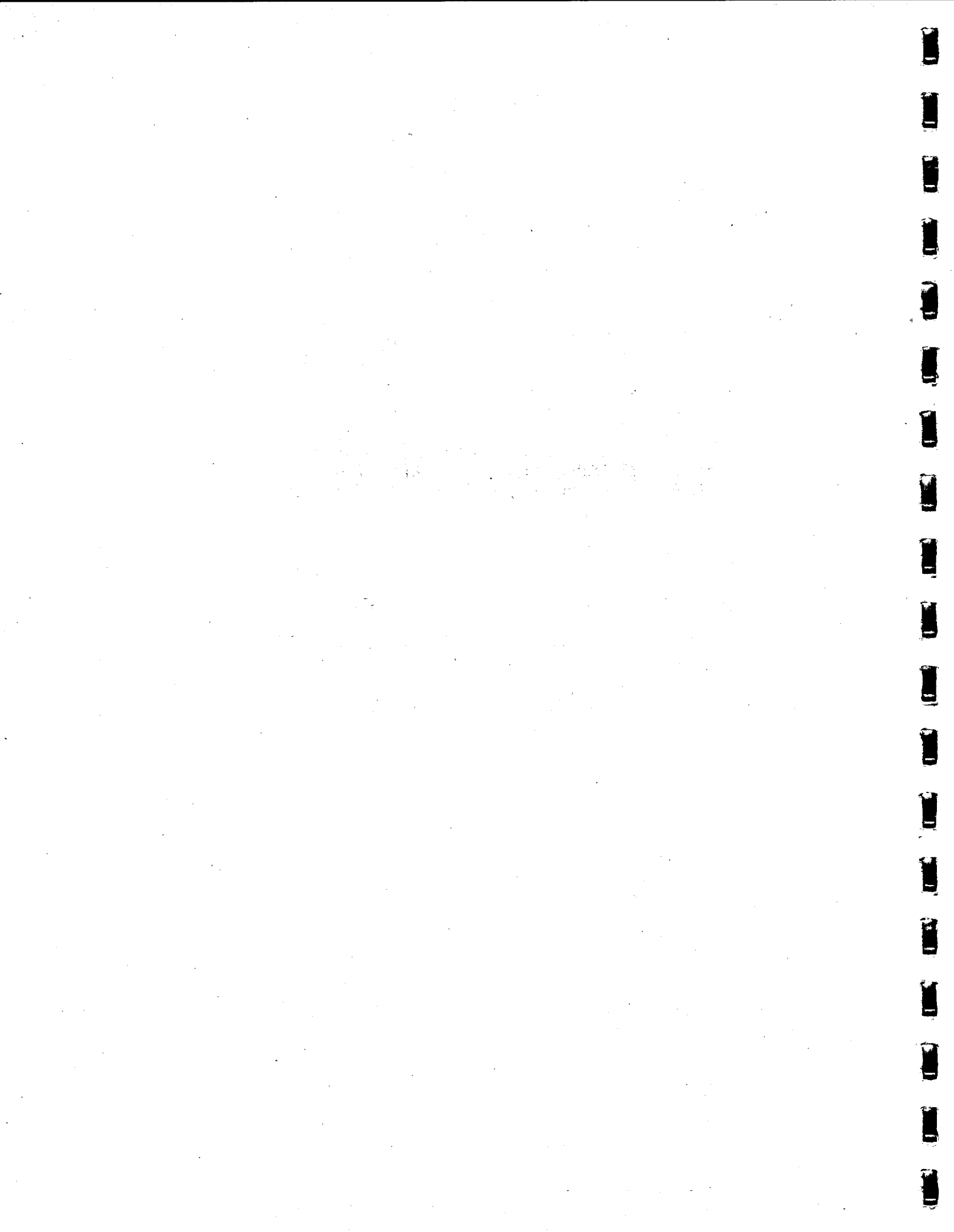

TMI-2 "QUICK LOOK" EXAMINATION*

W. A. Franz, EG&G Idaho, Inc.

R. L. Rider, Bechtel Northern Corp.

W. A. Austin, General Public Utilities Nuclear Corp.

N. Cole, MPR Associates, Inc.

The purpose of this work, conducted under the Department of Energy's Reactor Evaluation Program, was to gain the earliest possible access to the TMI-2 reactor vessel and to determine the condition of the plenum assembly and the reactor core. Completion of this examination has also provided substantial progress towards removal of the reactor vessel head and eventual defueling. The work was carried out by GPU Nuclear Corporation and their subcontractors, Bechtel Northern Corporation and Babcock & Wilcox (B&W). The work was sponsored and directed by the Technical Integration Office, operated for the Department of Energy by EG&G Idaho, Inc.

Uncoupling and parking of Control Rod Drive Mechanism (CRDM) leadscrews is a normal prerequisite to head removal for B&W pressurized water reactors. Because of the predicted core damage at TMI-2, it was uncertain whether all, or any, of the leadscrews could be uncoupled normally. In addition, some determination of the conditions within the reactor vessel was deemed necessary before committing to head removal.

* Work supported by the U.S. Department of Energy, Assistant Secretary for Nuclear Energy, Office of Coordination and Special Projects, under DOE Contract No. DE-AC07-76ID01570.

Two methods were developed for gaining through-head access. The first involves removal of an entire CRDM, providing a 6.8-cm-diameter access through the nozzle. In case normal uncoupling proved unsuccessful, contingency techniques were developed to disconnect the leadscrew. Two contingency procedures, one ex-head and one in-head, were developed. Both separate the leadscrew from the CRDM by cutting it with a plasma arc torch and separate the remaining leadscrew section from the control rod spider by shearing the pins connecting the leadscrew shaft to the bayonet fitting.

A second technique for through-head access, the so-called Quick Look technique, was developed at the suggestion of the Technical Assessment and Advisory Group (TAAG), a group of senior technical people funded by DOE to advise GPU Nuclear on the TMI-2 recovery. This simplified method involves uncoupling and removing a CRDM leadscrew by basically normal methods and inserting a Closed Circuit Television (CCTV) camera directly through the space vacated by the leadscrew. The leadscrew is 3.8 cm in diameter, and its removal provides a direct path into a control rod guide tube in the plenum assembly. The guide tube provides a direct path to the upper grid and the top of the reactor core.

From an inspection standpoint, the key difference between the two through-head access methods, other than the diameter of the pathway, is that removal of an entire CRDM, as in the first method, also removes the leadscrew support tube. The leadscrew support tube is a shroud that extends from the nozzle on the head to about 3.8 cm from the guide tube in the plenum assembly. With this shroud removed, access is available to the underside of the head and the top of the plenum assembly. When only the leadscrew is

removed, as in the Quick Look, access to this area above the plenum assembly is blocked. In spite of this possible disadvantage, the Quick Look access technique has the advantage of operational simplicity and some plant prerequisites are easier to satisfy.

Following initial mockup testing, the Quick Look was given a field test in TMI Unit 1. At the time, Unit 1 was shut down for repairs to its steam generators, and preparations were being made to remove the reactor vessel head and partially inspect the core. The Quick Look procedure was applied to a peripheral CRDM, and the results were very good. Especially important was the ability of the camera manipulator, using the CCTV cable and an attached tilt cable, to position the camera outside the insertion guide tube through flow holes at the bottom. This allowed a view of the four adjacent fuel assembly endfittings and adjacent guide tubes.

Following the successful test in Unit 1, work was started to apply the inspection technique to Unit 2. Conditions inside the Unit 2 reactor building are, of course, more difficult than those in Unit 1. And this inspection would be the first time since the accident that the reactor coolant system would be depressurized and the water level lowered. Both the primary and secondary levels were lowered to eliminate the possibility of unborated water leaking into the primary side. Water level control was established for both systems and the level dropped to just below the tops of the CRDM leadscrews in the scram position. This level coincided with the elevation of the main steam lines, simplifying secondary side level control.

Quick Look examination results are in three areas: initial venting and uncoupling of one or more CRDMS, video inspection, and reactor coolant and debris analysis. Results of samples of gas and liquid obtained during CRDM venting are presented.

Uncoupling results, including successes and failures and projected conditions causing any failures, are discussed. Results of the video inspection are presented, including a videotape of inspection highlights. Liquid samples obtained at several levels in the reactor vessel are evaluated, including analysis of any debris obtained.

TMI-2

Quick Look Examination

W.A. Franz
Senior project engineer
Reactor Evaluation Program

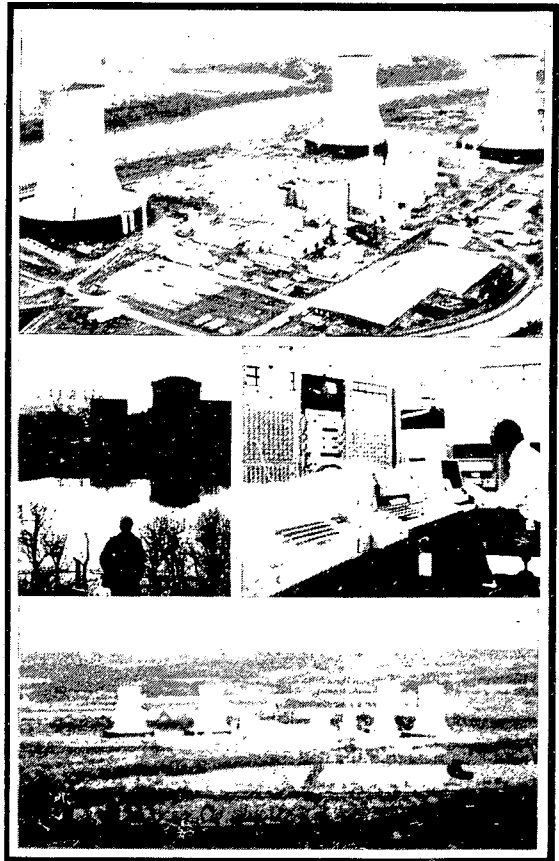

Purpose of Quick Look

- As-early-as-possible verification of core damage
- Provide information required for subsequent reactor disassembly
- Resolve concerns about breaching primary coolant system boundary

Quick Look Communications

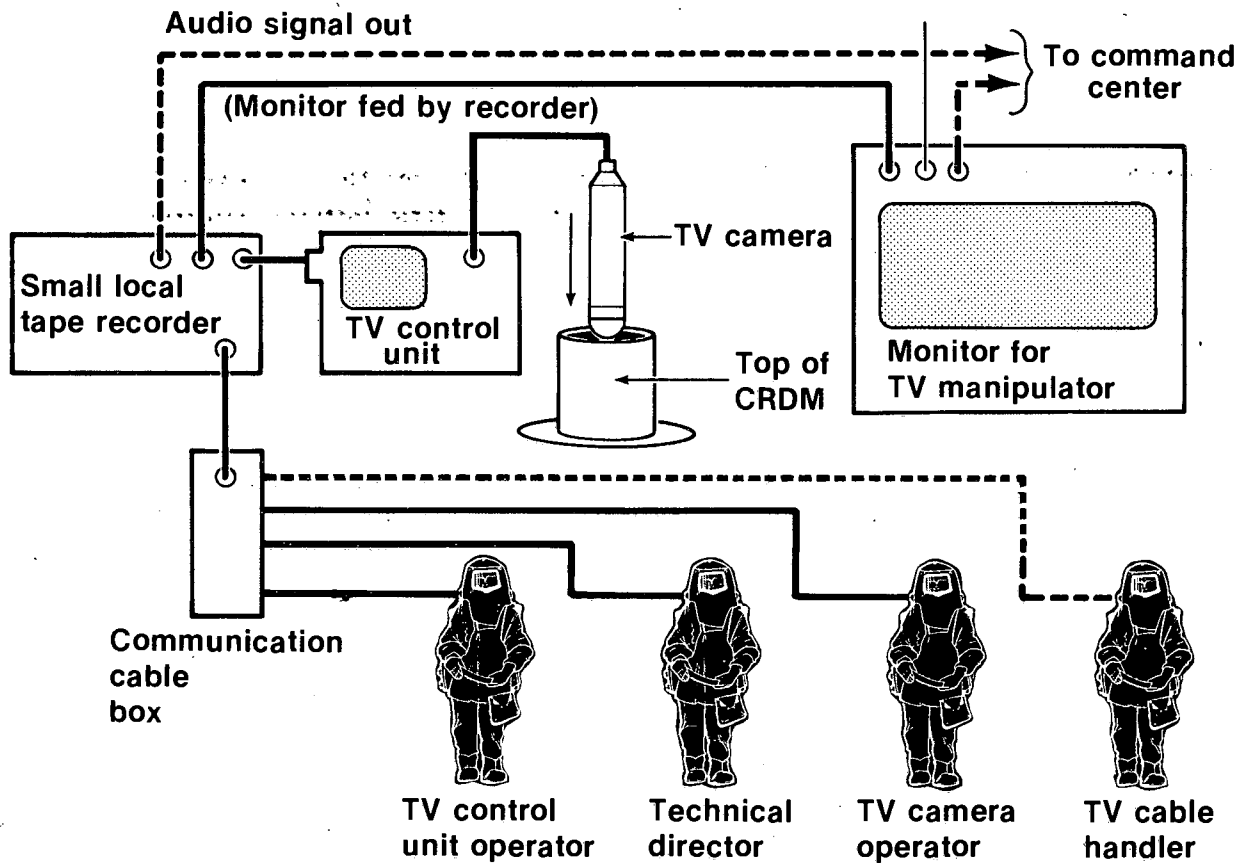

S2 3294

Split Headset Communications

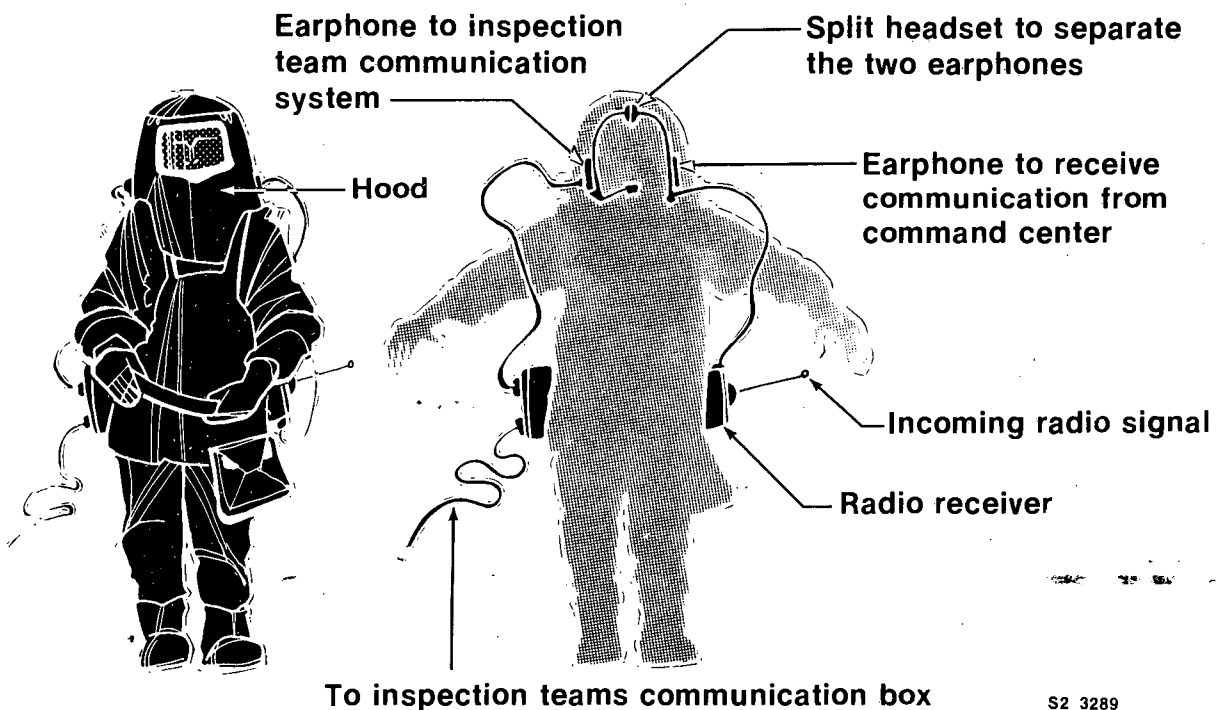

S2 3289

Leadscrew Pull Sequence

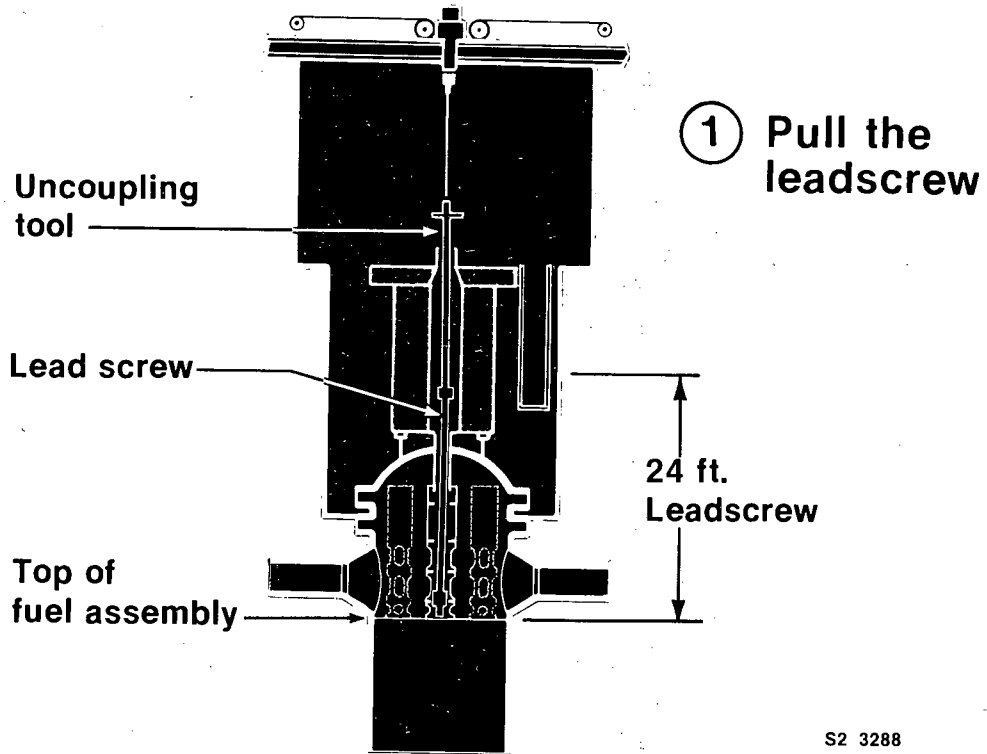

S2 3288

Leadscrew Pull Sequence

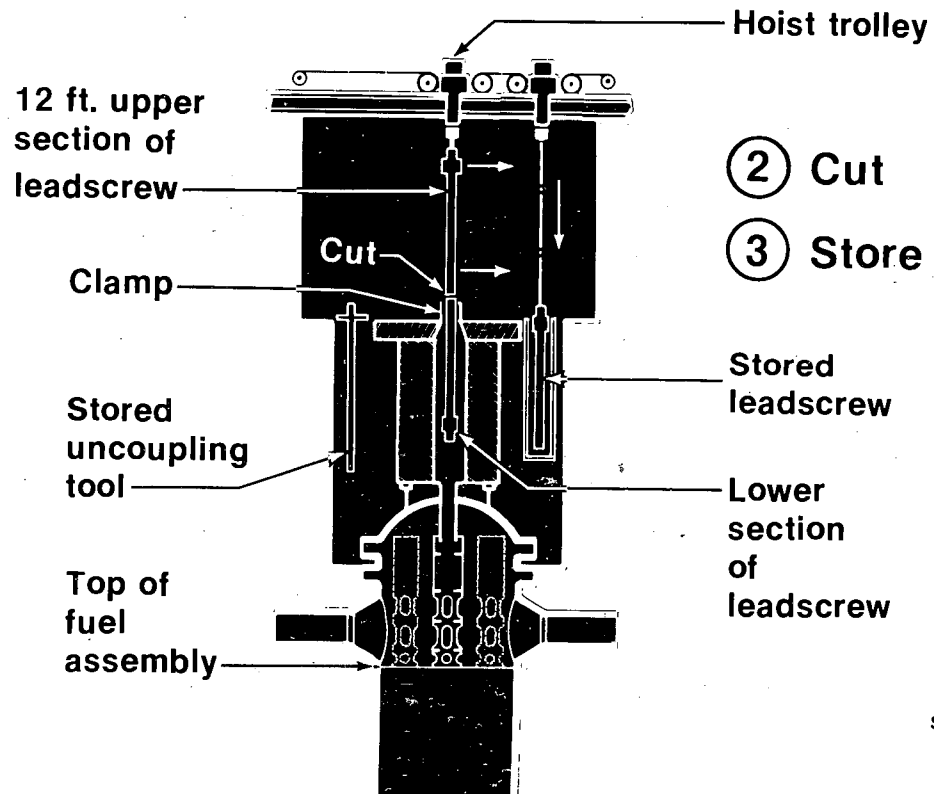

S2 3292

Quick Look Camera Path

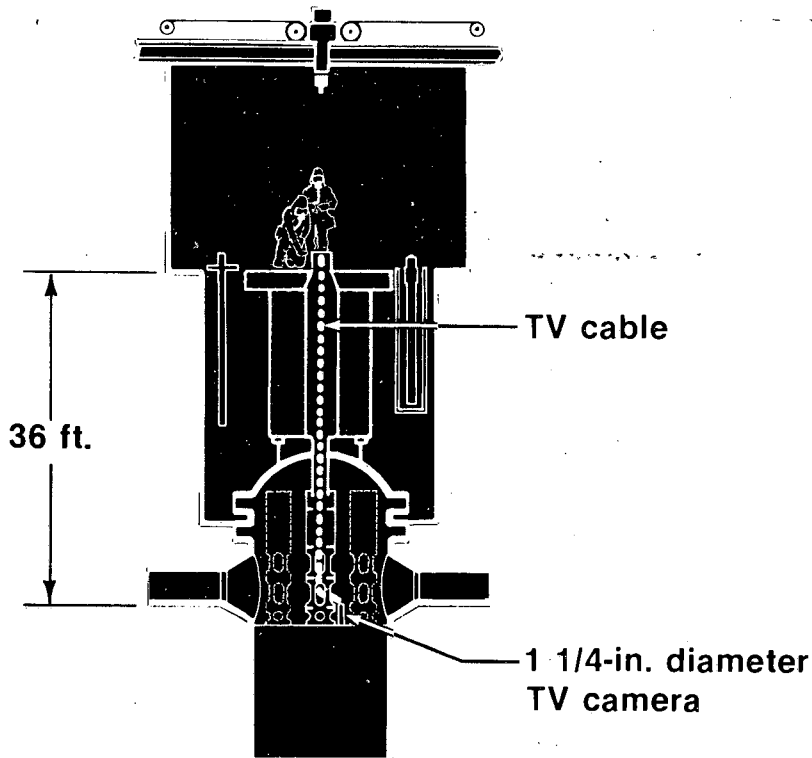

S2 3286

Top View of Upper Grid Assembly Showing Camera

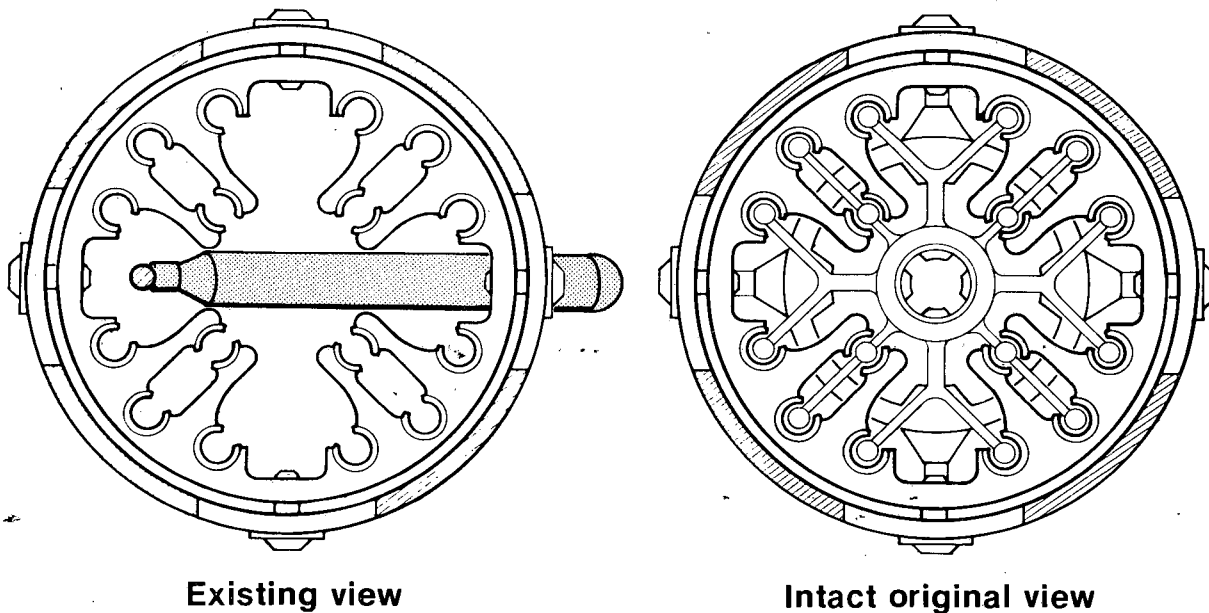

S2 3293

Top View Showing Camera "Kicking Out" to View Neighboring BPR

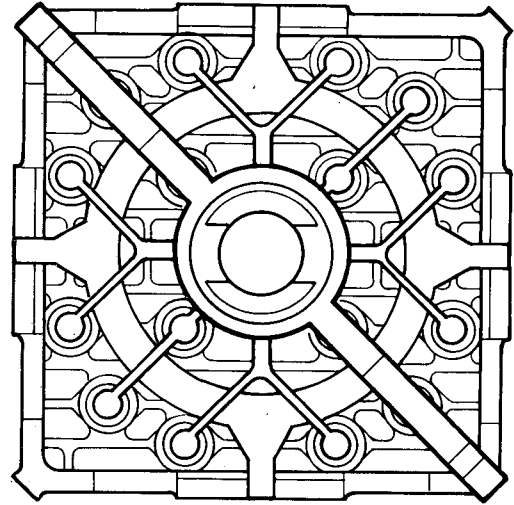
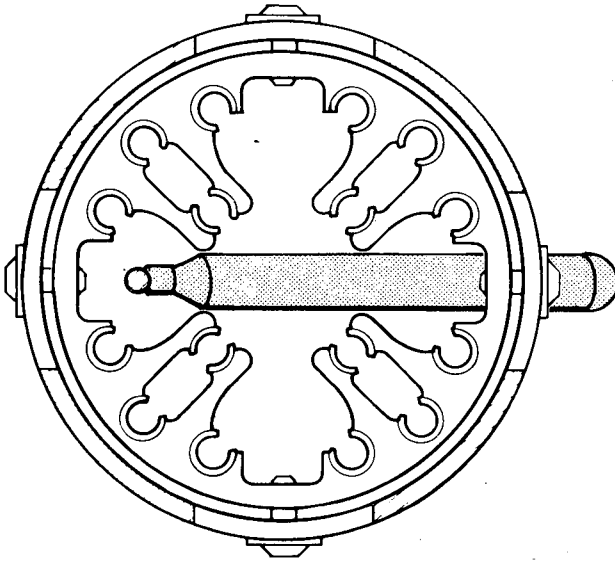

S2 3420

Camera Access

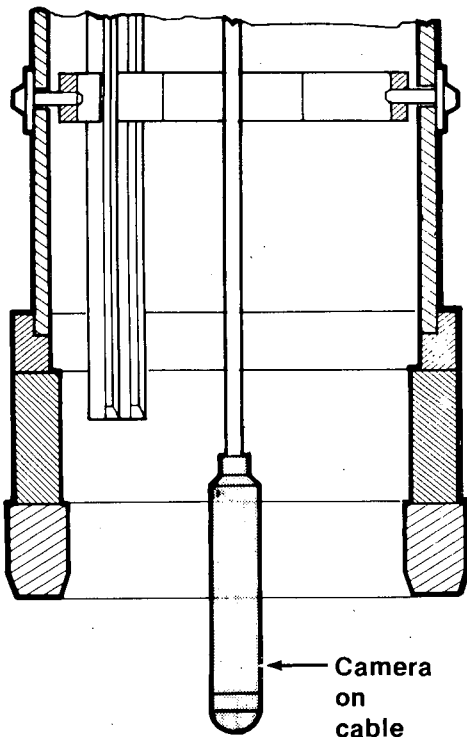

Existing view

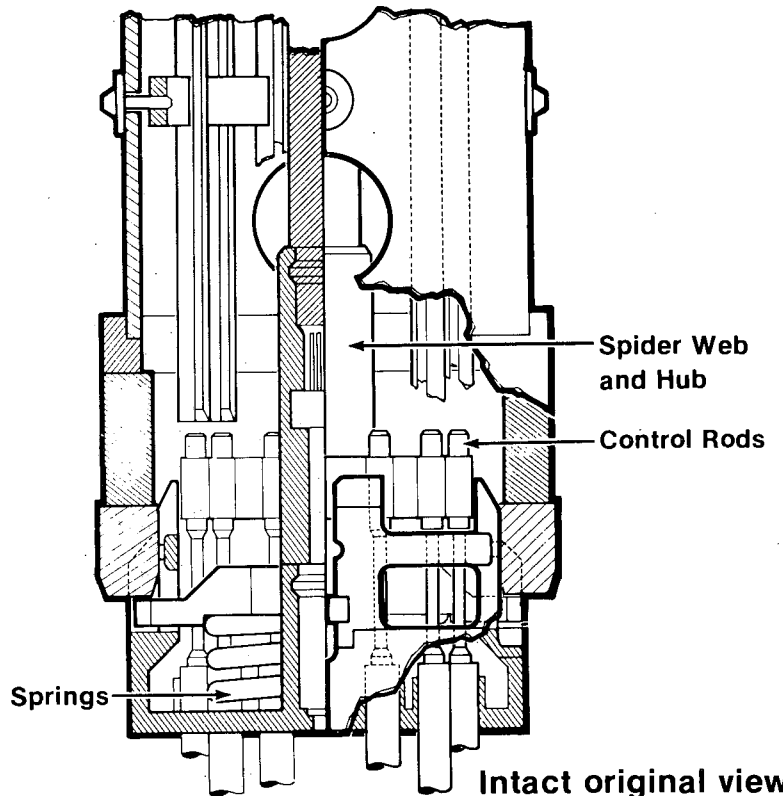

Intact original view

S2 3287

Predicted Upper Grid Area Damage

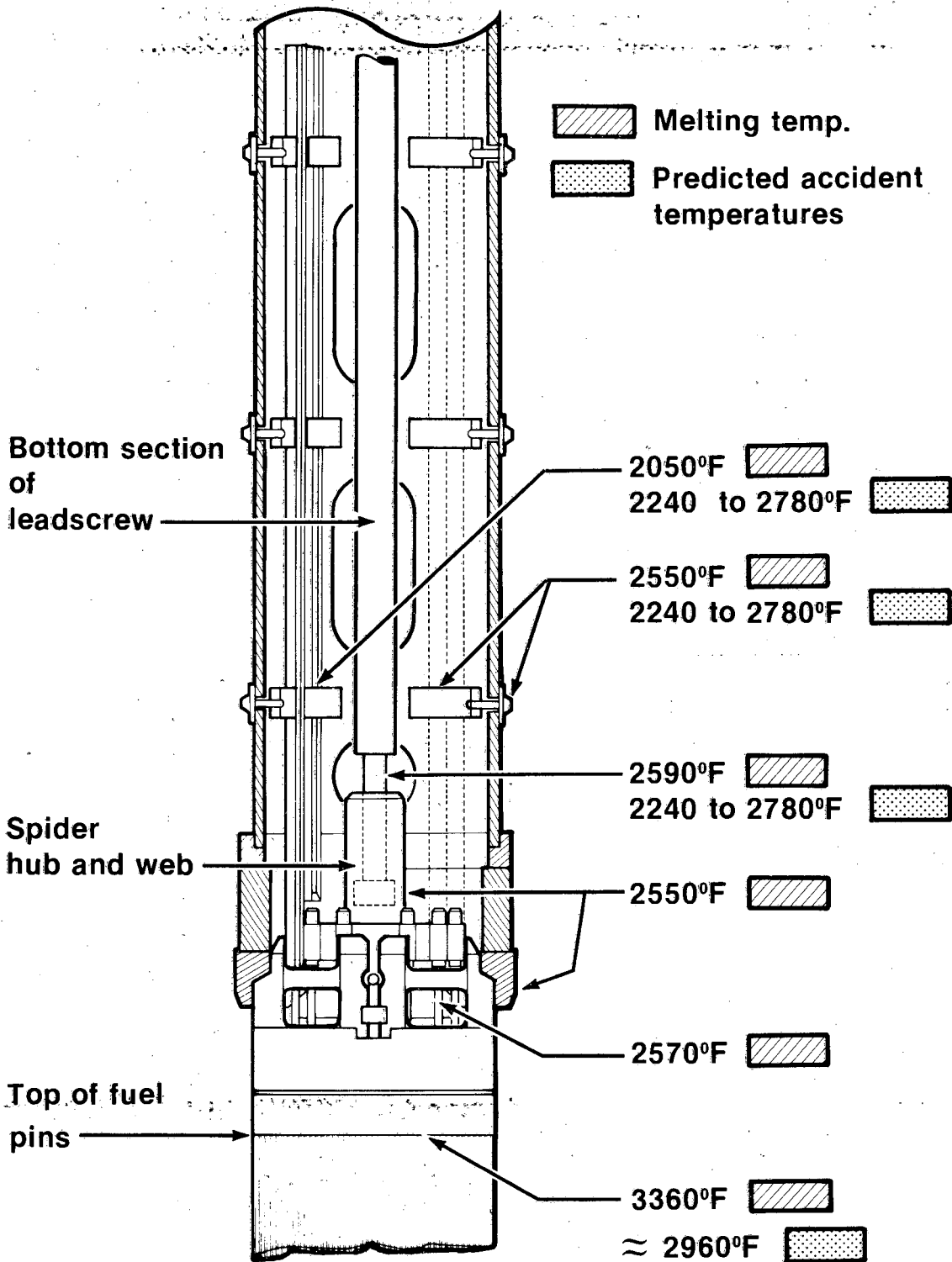

Possible TMI-2 Core Damage

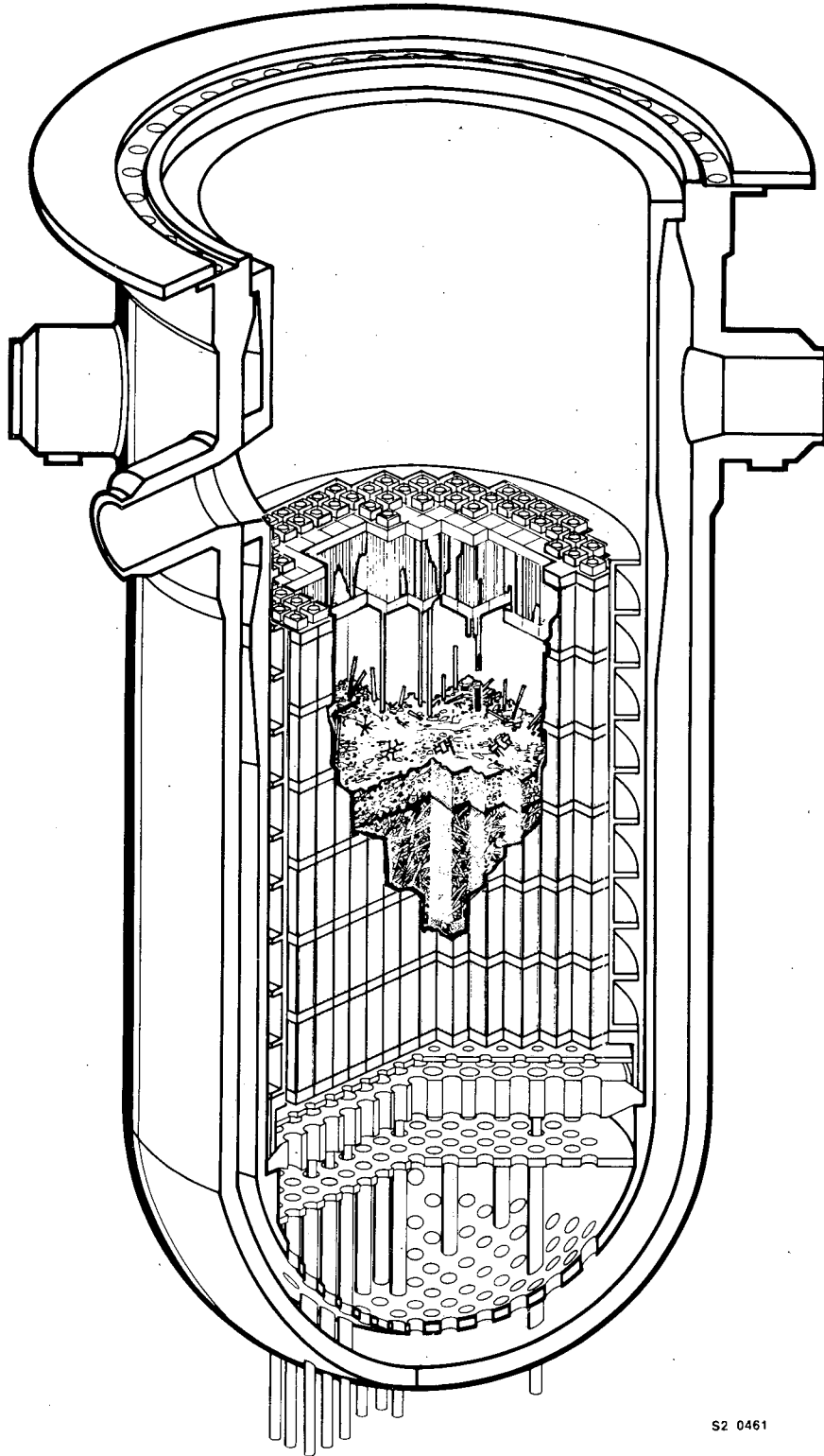

S2 0461

Edge of Visible Damage

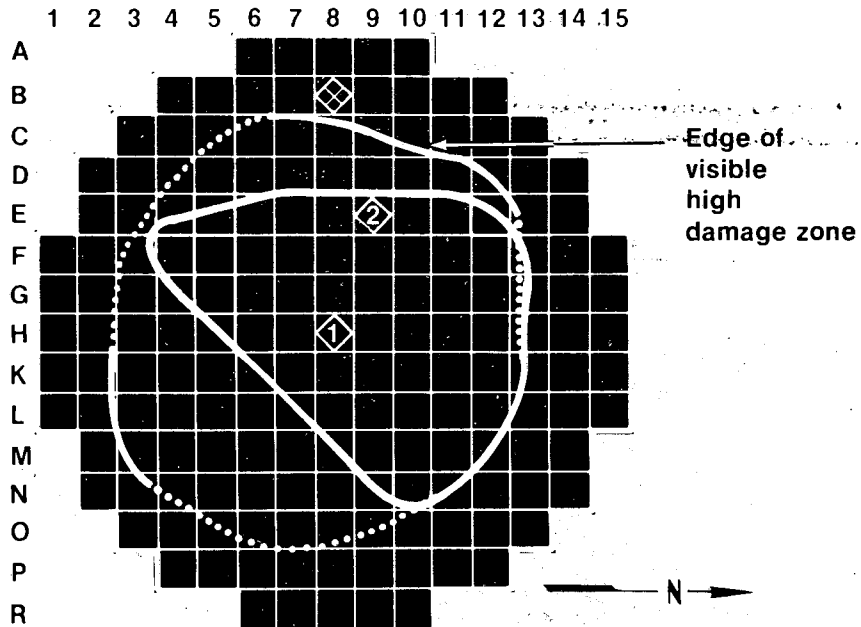

S2 3296

Conclusions

- Damage verified within range of predictions
 - Near the median predictions
- Next disassembly steps defined
- Reactor accessibility proven

S2 3290

TMI-2 CORE EXAMINATION: FIRST RESULTS:
D. E. Owen, M. R. Martin (EG&G Idaho, Inc.)

THE UNIVERSITY OF CHICAGO
LIBRARY

TMI-2 CORE EXAMINATION: FIRST RESULTS^a

D. E. Owen M. R. Martin

EG&G Idaho, Inc.

Although full access to the TMI-2 core has not been attained, a preliminary look into the core and the examination of some core materials have been achieved. The preliminary look (the so-called "Quick Look") during the summer of 1982 successfully maneuvered a closed circuit TV (CCTV) camera into the reactor vessel at 3 locations. The core materials which have been examined include the makeup system filter debris. The purpose of this paper is to present the latest findings from the core materials examinations as well as selected information from the "Quick Look" examinations and assess their implications on the condition of the TMI-2 core.

The makeup-letdown system of TMI-2 recirculates and purifies reactor coolant and supplies water to the reactor coolant pump seals. This system also supplies high-pressure injection of borated water during an accident. This system contains a number of particulate filters which plugged during the latter stages of the TMI-2 accident. A small sample of the debris from one filter was analyzed by B&W and EG&G Idaho in 1981. These analyses indicate that the debris was only 6 percent uranium, indicating a relatively low fuel (UO_2) content. The principle component of the debris was Zr, presumably ZrO_2 from oxidized fuel cladding. Ag, In, and Cd, the constituents of the control rod alloy, were also detected at a fairly high concentration indicating that at least some of the control rods failed. The debris particle sizes were <1 to $5\mu m$, with some larger (presumably) agglomerates of $25-50\mu m$. The particle size data may be misleading, however, because this preliminary sample was ball-milled to achieve homogeneity prior to analysis.

a. Work supported by the U.S. Department of Energy Assistant Secretary for Nuclear Energy, Office of Coordination and Special Projects, under DOE contract No. DE-AC07-76ID01570.

In early 1982, before the Quick Look, five makeup system filters caked with particulate debris were removed from the filter housings. Loose debris from these housings was also obtained by vacuuming the housings following filter removal. The debris was sent to EG&G Idaho and LANL for detailed physical and chemical analyses. The results of these analyses will be reported, including SEM photographs, particle size data, chemical composition and fission product content. The preliminary B&W and EG&G Idaho analyses on the particulate filter sample from 1981, described above, seem to indicate that substantial quantities of fuel cladding were oxidized and the cladding, fuel, and control rods were extensively fragmented. Based upon the quantity of particulate core debris which reached the makeup system filters, debris relocation throughout the primary system appears extensive.

The findings of the makeup filter debris analyses are presented and their implication on core temperatures and extent of core damage are assessed. The Quick Look findings are addressed briefly and they too are analyzed for what they reveal about the level of core damage. The results of the core materials studies are compared to the Quick Look findings to determine if a consistent picture of the core condition emerges from these two core examination activities.

AN OVERVIEW OF THE TMI-2
CORE EXAMINATION PLAN:
K. C. Sumpter (EG&G Idaho), K. A. Trickett,
E. Feinauer (DOE-Idaho), D. E. Owen,
M. R. Martin (EG&G Idaho)



AN OVERVIEW OF THE TMI-2
CORE EXAMINATION PLAN

K. C. Sumpter, EG&G Idaho, Inc.
K. A. Trickett, DOE-Idaho
E. Feinauer, DOE-Idaho
D. E. Owen, EG&G Idaho, Inc.
M. R. Martin, EG&G Idaho, Inc.

The TMI-2 Core Examination Plan presents a logical organization for the sampling, examination, and ultimate utilization of the data made available from the recovery program of the TMI-2 Nuclear Plant. The plan emphasizes cooperative efforts not only between the defueling team and those dedicated to the analysis of the data but also among the various laboratories and commercial facilities participating in the program.

Dealing with the defueling sequence, the core examination addresses three basic objectives: understanding severe core damage initiation, propagation, and termination; supporting the technical basis for existing regulation; and improving LWR design and operation. The mere understanding of the March 1979 accident mandates fundamental reasons for examining the TMI-2 core. During all phases of the recovery effort the plan intends to utilize the information used to assist the actual defueling operation. By the same token specialized equipment to obtain data meeting the plan objectives is available to the defueling contractor. For instance, prior to removing the head a closed circuit television camera was lowered into a leadscrew guide tube in an attempt to gain first hand knowledge of the reactor internals. The camera inspection offered an opportunity to assess temperature profiles by observing guide tube brazements, component oxidation, component relocation, and adjacent assembly inspection. The leadscrew removed from the reactor was sent to the Idaho National Engineering Laboratory (INEL) for metallurgical examination again offering the first substantial opportunity to evaluate actual upper plenum temperatures achieved during the accident.

After head removal the plan suggests minimal activity with the plenum assembly in place. Plenum cover distortion, observations debris examination, and sampling provide the basis for post-head/pre-plenum inspection.

It is also worth noting an alternative core damage method is presented using the 52 instrumented fuel assemblies. Only if a significant delay in plenum assembly removal is encountered should the alternative be considered. It is suggested feeler gauges such as piano wire be inserted from the cable spreading room into the core. Depending on the degree of insertion a measure of damage could be achieved. Actual inspection and sampling of the plenum assembly will take place away from the defueling activity if appropriate. TV camera inspection is suggested to evaluate the condition of the peripheral fuel assemblies not only for data collection but also for defueling preparations. Correlations with the hot and cold legs, and variations in debris and plenum damage will be noted including any asymmetry. Also at this time a core topography measurement system will be introduced. This system will measure the core cavity before the plenum assembly is lifted thus mapping the as-is condition. The system uses existing range finding technology and will have little impact on the defueling process. It is further expected that this measurement will be used throughout the defueling operation to permanently document the morphology of the damaged core. Used in conjunction with photographic techniques a permanent three dimensional map will be available for subsequent analysis.

Much of the sample choices will be made during the on island activities with the main examination activity proceeding after the material has been shipped to the INEL. However, it is imperative that the data acquisition group and refueling group work closely. Several sample selection categories have been developed and viewed as reasonable considerations to allow some perturbation in the defueling sequence as follows: at least one intact fuel assembly, assemblies exhibiting gradation of damage, typical debris, debris changes (morphology), and non fuel features. One of the key issues being worked is core damage stratification preservation and--most significant--coolable geometry configuration, a difficult issue. The suggested utilization of liquid Nitrogen "cold fingers" provides a method of stabilizing and removing

"undisturbed" vertical samples subsequently immobilized for transportation to the INEL. Every attempt is being made to use engineered technologies and minimize the disruption to the defueling operations. Several pieces of data have been obtained through laboratory examination of the make-up filters and the first leadscrew removed from the core. These data along with the observations made during the quick look camera inspection in July have been integrated into the remaining core examination objectives. The plan is guided by the Core Damage Assessment Technical Evaluation Group and includes discussions pursuant to further examination of the reactor vessel head, plenum, intact assemblies (if any), partial assemblies, fuel and structural debris, and fuel rod stubs.

Finally the core examination plan addresses data application and why the information is necessary. Basic degraded core accident understanding lending some insight to the effects of reactor operation, component survivability, flow behavior in the core, and material distribution during this class of accident are issues needing additional confirmatory analysis and are uniquely available through the TMI-2 core examination. As the data are obtained and evaluation by the TEG, industry, and others is performed, assessment regarding subsequent information needs will be necessary.

1. The first part of the document discusses the importance of maintaining accurate records of all transactions. It emphasizes that proper record-keeping is essential for the integrity of the financial system and for the ability to detect and prevent fraud. The text also notes that records should be kept for a sufficient period to allow for a thorough audit.

2. The second part of the document outlines the specific requirements for record-keeping. It states that all transactions must be recorded in a clear and concise manner, and that the records must be accessible to all authorized personnel. The text also mentions that records should be stored in a secure location and that appropriate controls should be in place to prevent unauthorized access or modification.

3. The third part of the document discusses the role of internal controls in ensuring the accuracy and reliability of financial records. It highlights that internal controls are designed to prevent errors and to detect any irregularities. The text also notes that internal controls should be regularly reviewed and updated to reflect changes in the business environment.

4. The final part of the document provides a summary of the key points discussed. It reiterates the importance of accurate record-keeping and the role of internal controls in maintaining the integrity of the financial system. The text concludes by stating that these measures are essential for the success of any organization.

TMI-2 INSTRUMENTATION AND MECHANICAL EQUIPMENT SURVIVABILITY

0 0 1 2 3 4 5 6 7 8 9 10 11 12 13 14 15 16 17 18 19 20 21 22 23 24 25 26 27 28 29 30 31 32 33 34 35 36 37 38 39 40 41 42 43 44 45 46 47 48 49 50 51 52 53 54 55 56 57 58 59 60 61 62 63 64 65 66 67 68 69 70 71 72 73 74 75 76 77 78 79 80 81 82 83 84 85 86 87 88 89 90 91 92 93 94 95 96 97 98 99

THE INSTRUMENTATION AND ELECTRICAL PROGRAM AT TMI-2:
W. F. Schwarz (EG&G Idaho, Inc.)

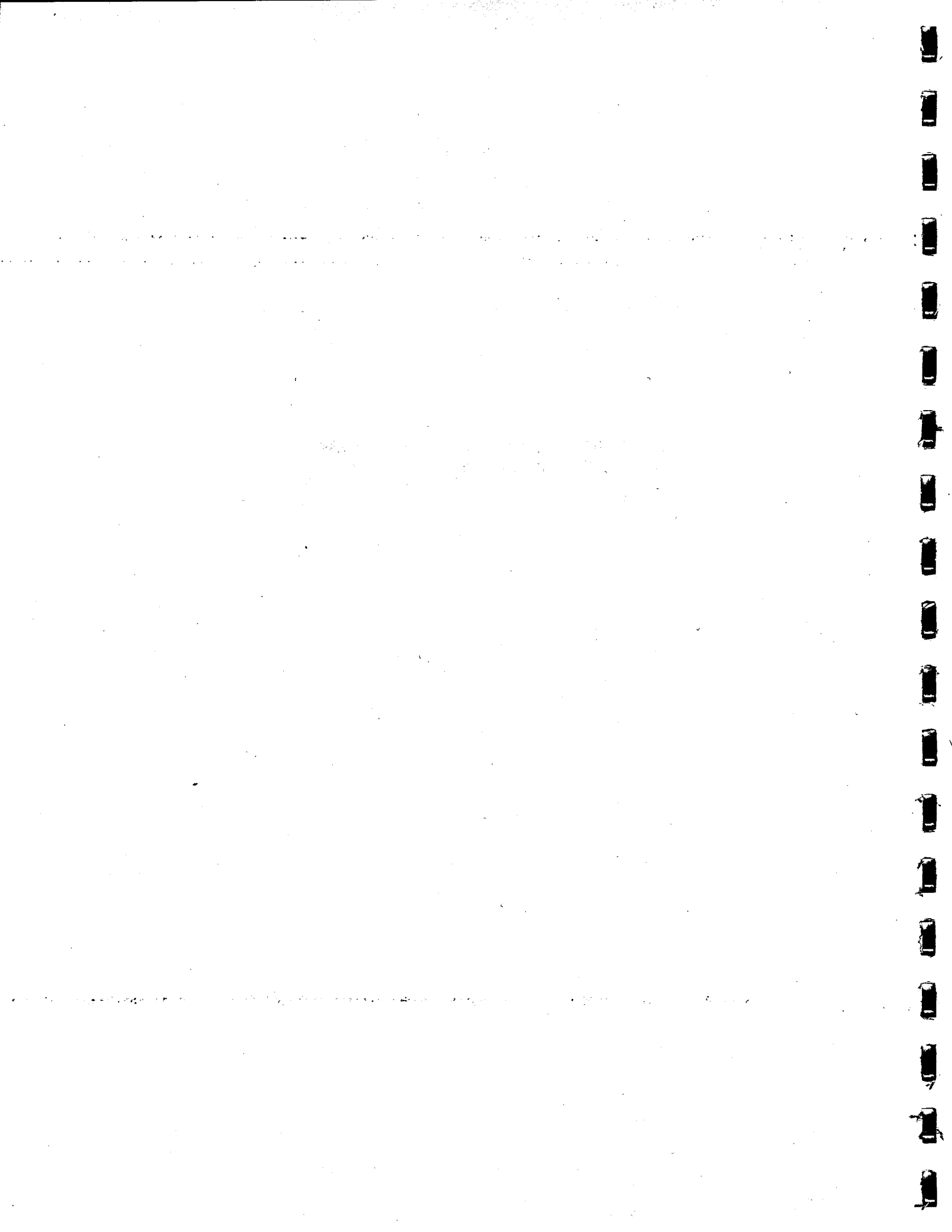

THE INSTRUMENTATION AND ELECTRICAL PROGRAM AT TMI-2*

W. F. Schwarz, EG&G Idaho, Inc.

The Instrumentation and Electrical (I&E) Program has the basic objective of acquiring data on the ability of the instrument and electrical components and systems to continue to perform their intended functions during and after a loss of coolant accident. In order to meet the objective, the I&E program has developed an examination and test plan. Since it would be impossible to examine the more than 1,000 instruments in the TMI-2 containment building, a list of 226 samples was developed by an industry committee. This list was later expanded to include all 52 in-core thermocouples and all 416 in-core self-powered neutron detectors (SPNDs) and background elements.

Evaluation consists of first testing these devices in situ, typically by passive resistance and reactance measurements and by time domain reflectometry (TDR) techniques. The objective is to determine the condition and operability of each device. 573 instruments, including the 468 in-core detectors, have been in situ tested to date. About 80% of the devices tested exhibited some anomaly. In addition, some dynamic testing has been conducted: eight control rod drive mechanisms were operated to assess movability of their control rod assemblies. All eight operated normally.

Results of the in-core instrument in situ tests indicate extensive core damage. There are seven SPNDs and one background element (BE) in each instrument assembly at 52 locations in the core. These normally have very high center conductor-to-sheath resistances, so low resistances or shorts were considered failures due to damage. At more than half of the 52 locations, all SPNDs and the BE were failed. At the other remaining locations, one or two

* Work supported by the U.S. Department of Energy, Assistant Secretary for Nuclear Energy, Office of Coordination and Special Projects, under DOE Contract No. DE-AC07-76ID01570.

SPNDs at the core bottom appeared normal, but the others were failed. Most of the 52 in-core thermocouples are still providing consistent, believable temperature readings. The original junctions were in a plane about 18 cm (7 in.) above the top of the core. The cables pass down through the core, exiting through the bottom of the reactor vessel. Half of these thermocouples showed a charging effect when resistance readings were taken; that is, the meter current charged the thermocouple cable as if it were a resistive-capacitive circuit with a long time constant. This indicates wetted insulation and hence physical damage. Resistance data also indicate that most of the thermocouples are shorter, and their present "junctions" are not at the original location.

Following in situ and dynamic testing, selected devices are physically removed from containment and sent to various laboratories for detailed physical examinations. At this writing, 16 have been removed and several have undergone examination, including four radiation monitors, two pressure transducers, three pre-amplifiers, a pressure switch, and several cable samples.

Three identical area radiation detectors were examined at Sandia National Laboratories (SNL), and all were failed. One was damaged by water entering a connector; the others had failed GM tubes. When repaired, they all showed a multivalued output effect, as did a new reference detector. At incident levels several decades above the specified range for these detectors (10^{-4} to 10 R/h), the ratemeter readings began decreasing with increasing radiation. At this writing, the manufacturer is being consulted on the matter, and there are plans to advise users of this effect.

Charge converters used in the loose parts monitoring system were found by SNL to be radiation sensitive, and to fail at about 10^5 R accumulated dose. They degrade in a way which produces a decreasing output for a constant noise level, meaning that an increasing noise level might not be detected. This has been reported before, and there has since been an increased effort to assure that other users are aware of it.

The TMI-2 dome radiation monitor has been delivered to SNL for examination and analysis. This single instrument, a shielded ion-chamber device, was mainly responsible for the decision to begin evacuation of communities adjacent to TMI during the 1979 accident. It is now known that this instrument indicated radiation levels that were unrealistically high, probably by several orders of magnitude. Thus, results of Sandia's evaluation will be of great interest to the I&E Program.

All results of the I&E Program which are of potential interest to the owner/operators of other nuclear generating stations are systematically communicated to them. Results having any apparent safety implications are additionally evaluated by the Institute of Nuclear Power Operations (INPO) for their significance, and recommendations for appropriate changes are made. By these activities and others, the information being acquired at TMI-2 is being used to further improve the reliability and safety of nuclear plants.

Faint, illegible text, possibly bleed-through from the reverse side of the page. The text is too light to transcribe accurately.

TMI-2

Instrumentation and Electrical Program

L.A. Hecker
Engineer
I & E Program

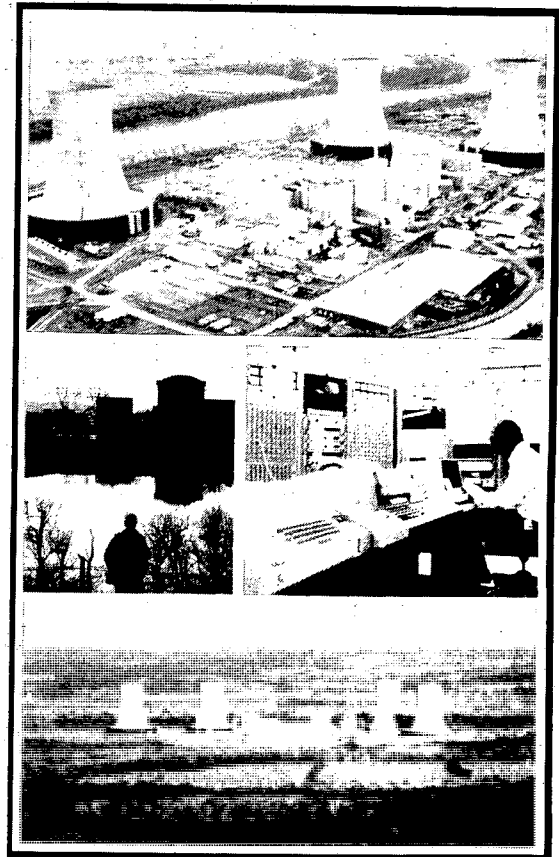

Instrumentation and Electrical Program Objectives

Survivability

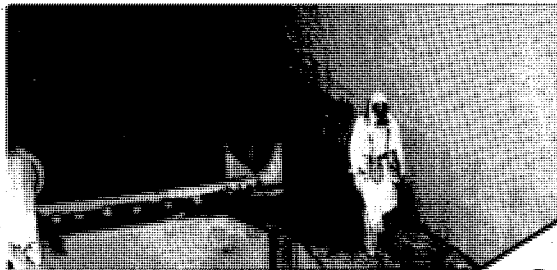

Standards

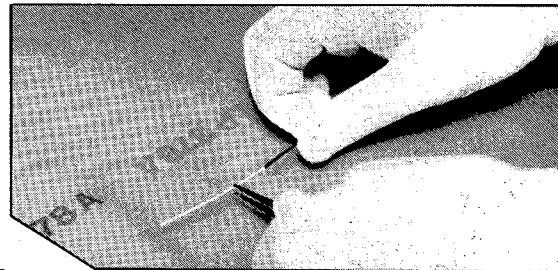

Safety



Qualifications

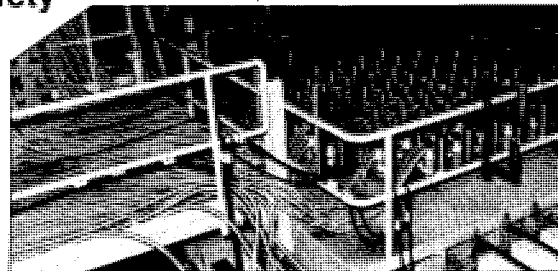

Installation at TMI

Instrumentation and Electrical Program Determines Adequacy of:

- **Systems and equipment to withstand accident conditions**
- **Qualification procedures**
- **Current instrumentation and electrical standards**
- **Plant construction and installation procedures**
- **Plant operating and maintenance procedures**

T10-LAH-5

Instrumentation and Electrical Components

- **All I&E work could influence**
 - Standards and regulatory guides
 - Qualification requirements
 - Installation procedures
 - Performance requirements

S2 4012

Instrumentation and Electrical Areas of Interest

- **Radiation monitors**
- **Incore instrumentation**
- **Electrical cables**
- **Polar crane**
- **Radiation qualification and damage**

S2 4013

Sample Selection Criteria

- **Fifteen generic categories**
- **Varied environmental conditions**
 - **Temperature**
 - **Wetting**
 - **Radiation**

T10-LAH-6

Electrical Cables

- **Determine survivability through**
 - **In situ testing**
 - **Materials analysis**
 - **Evaluation of principal environmental effects**
- **Lay groundwork for future tasks**
 - **Cable system requalification**
 - **Postaccident lifespan determination**

S2 4014

Polar Crane

- **Has high concentration of components**
 - **Switches, contactors, 14 motors**
- **In an area of relatively low radiation**
- **Suffered damage during hydrogen burn**
- **In situ tests and entry examinations do indicate generally good condition**

S2 4016

Radiation Qualification and Damage

- **Loose Parts Monitors failed**
 - **Charge converter MOS-FET transistors failed in high radiation due to accident releases or location too close to reactor vessel**
- **HP-R-211 cable specimen showed no detectable radiation damage to insulation or sheath**

S2 4015

Program Testing Status as of September 1982

- **45 in situ tests completed on discrete devices**
 - **31 devices operating properly**
 - **14 devices exhibit anomalies**

S2 3625

Removal and Off-site Testing

- 18 components removed from the reactor building for detailed analysis
 - HP-R-211 Radiation Monitor
 - Loose Parts Monitoring System Charge Converter
 - HP-R-214 Radiation Monitor

S2 3624

Radiation Monitor HP-R-211 Disassembled

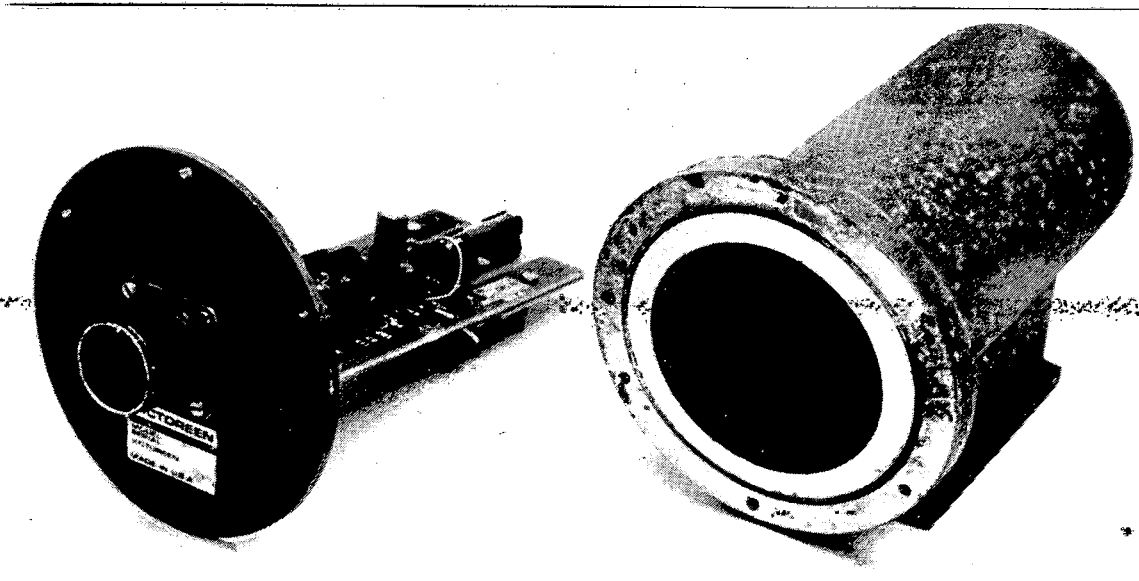

T10-LAH-15

Failure of HP-R-211 Radiation Detector

Detector installed with connector entering through the top

Building spray enters improperly mated connector back-shell...

Shorts occur and instrument fails.

T10-LAH-16

Radiation Monitor Foldover Effect

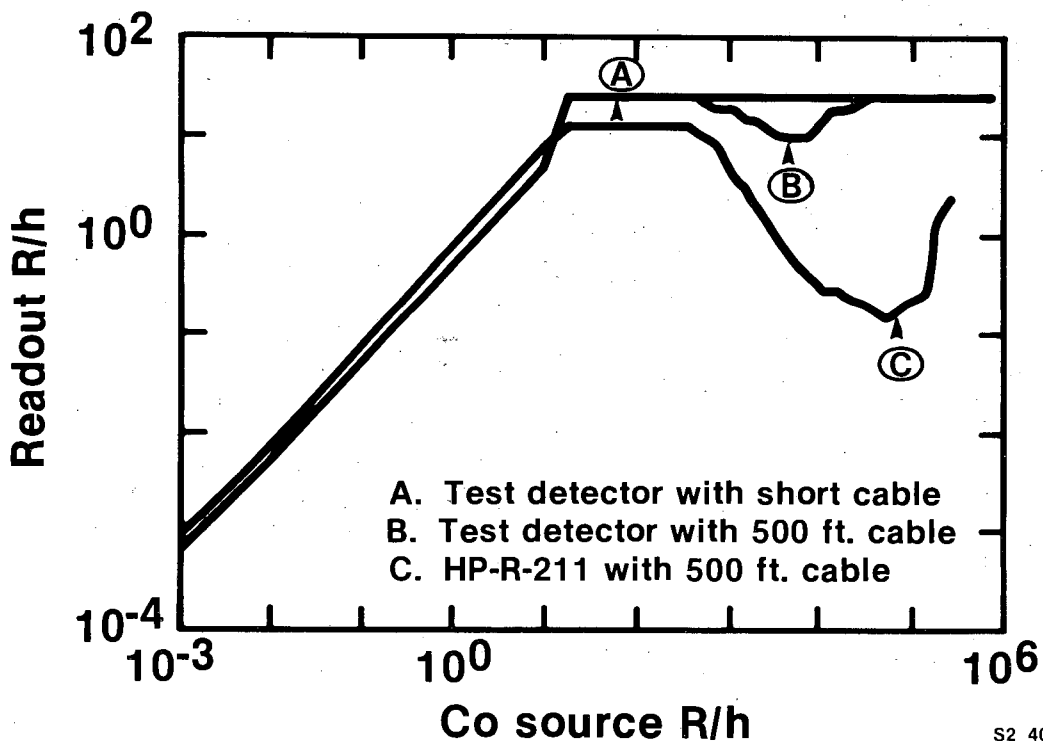

S2 4011

Loose Parts Monitor Charge Converter

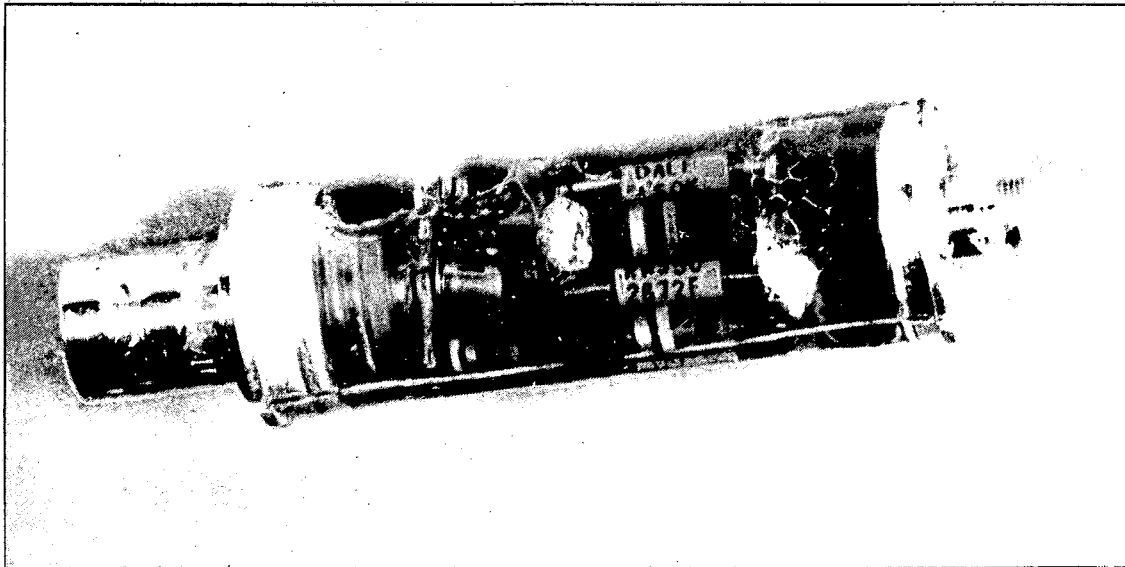

T10-LAH-17

Loose Parts Monitoring System Charge Converter Analysis Conclusions

- Distorted or no output caused by radiation degradation in MOS transistors
- Estimate this design usable up to only 1.2×10^5 rads
- Converters examined received 9×10^4 and 2.2×10^5 rads
- MOS transistors are not suitable for use in high radiation areas

T10-LAH-18

Dome Monitor Examination

Indications to date:

- Failed electrolytic capacitor could have caused low readings
- Sealed housing apparently leaked
- Pre-accident calibration procedure could have trapped moisture inside seal
- Moisture, corrosion, and contamination found inside

S2 4017

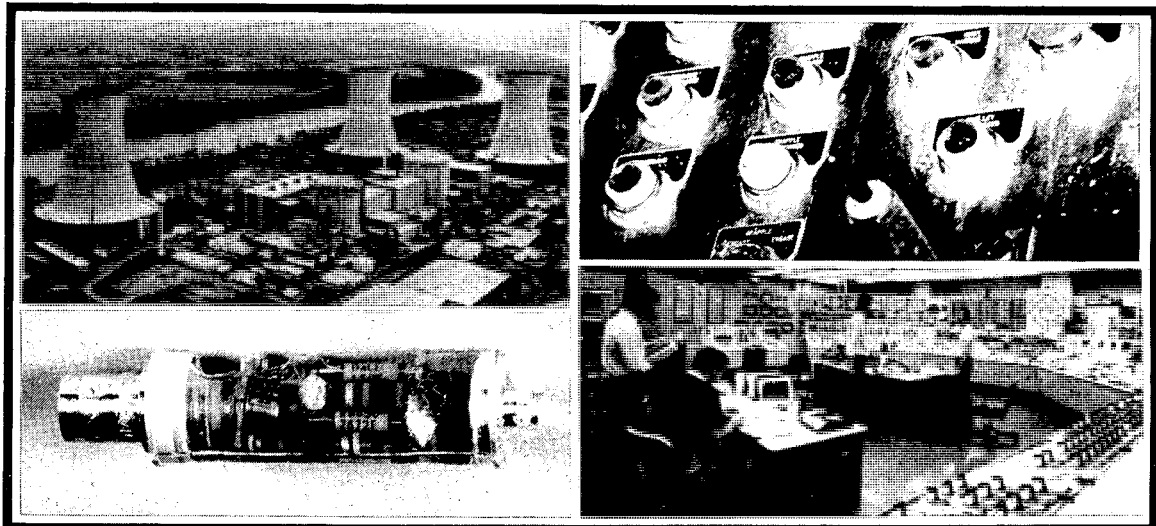

**Instrumentation and Electrical Program
Contributes to Understanding of
Equipment Behavior During and
Following an Accident**

T10-LAH-19



TMI-2 SPND AND THERMOCOUPLE DATA ANALYSIS:
M. E. Yancey (EG&G Idaho, Inc.)

THE UNIVERSITY OF CHICAGO



TMI-2 SPND AND THERMOCOUPLE DATA ANALYSIS*

M. E. Yancey, EG&G Idaho, Inc.

As a result of the March 28, 1979 accident at TMI-2, the in-core neutron detection and temperature measurement instrumentation was subjected to above-normal temperatures and consequently suffered considerable damage. This in-core instrumentation includes 364 self-powered neutron detectors (SPNDs), 52 background detectors for gamma compensation, and 52 thermocouples.

A two-phase test program was undertaken to assess the extent of damage to this instrumentation. The first phase involved in situ testing at TMI-2 and included the measurement of thermoelectric voltage, loop resistance, and the resistance of each lead to ground for each of the thermocouples, as well as the resistance measurement on each of the SPNDs and background detectors. A time domain reflectometry (TDR) technique was used to provide additional data on the present status of the in-core detectors.

The second phase involved laboratory tests to provide a baseline for understanding data obtained during in situ testing. One laboratory test was conducted to identify the effects of moisture on resistance measurements. This test indicated that moisture present in the insulation of an open-circuit in-core detector or thermocouple caused a charging effect as resistance measurements were attempted. Laboratory testing also revealed that moisture in the insulation of a thermocouple did not effect the loop resistance measurement. Furthermore, laboratory evaluation of the

* Work supported by the U.S. Department of Energy, Assistant Secretary for Nuclear Energy, Office of Coordination and Special Projects, under DOE Contract No. DE-AC07-76ID01570.

TDR technique demonstrated the ability to distinguish between opens and shorts in the in-core instrumentation. The presence of moisture in the insulation could be sensed with the TDR even though the moisture had no noticeable effect on resistance measurements.

Initial test data indicated that 26 of the thermocouples had failed junctions with moisture in the insulation. Two of the thermocouples had open junctions and were dry. The remainder of the thermocouples had apparent junctions although the location of the junctions was not certain. Probable locations of the junctions were determined by comparing in situ resistance test data with postinstallation test data. With laboratory test confirmation that no shunting occurred in thermocouple resistance due to moisture in the insulation, it was possible to calculate the apparent junction location for each shorted thermocouple. Differences from installation location occurred in each case, with the greatest differences occurring in the center area of the core. The results of this evaluation were prepared in a three-dimensional plot showing the apparent change in the location of the thermocouple junction.

Of the in-core detectors, 22 had insulation resistances greater than 10^9 ohms and were considered to be good. The majority of these detectors were in the lower levels of the active core area. Of the remaining in-core detectors, 331 exhibited open-circuit characteristics with moisture in the insulation, and 56 detectors, located mainly in the center of the core, indicated a more severe failure mode, namely a short-circuit condition.

Available in-core detector and thermocouple data from before and after the accident have been subjected to statistical grouping and analysis in order to establish discrete classes of instrument damage. These results indicate the center of the core probably experienced the most severe damage. This is graphically represented by a boundary that can be called the lower damage limit for the in-core instrumentation. The thermal history of this boundary area is not well known. Laboratory tests were conducted in an

attempt to reproduce the short condition on the SPNDs as a function of temperature, but the tests proved inconclusive. Sheath failure, which is indicative of the 331 in-core SPNDs that exhibit open circuits, represents a minimum temperature excursion of 1370 to 1425°C for thermal damage only or as low as 925°C if rapid quenching is also considered, as determined earlier by Babcock and Wilcox.¹ Additional in situ testing and data reduction will be performed in an effort to better understand failure mechanisms and postaccident data.

REFERENCE

1. Holland D. Warren, Babcock and Wilcox Co., SPND Thermal Currents in a Furnace, July 1979.

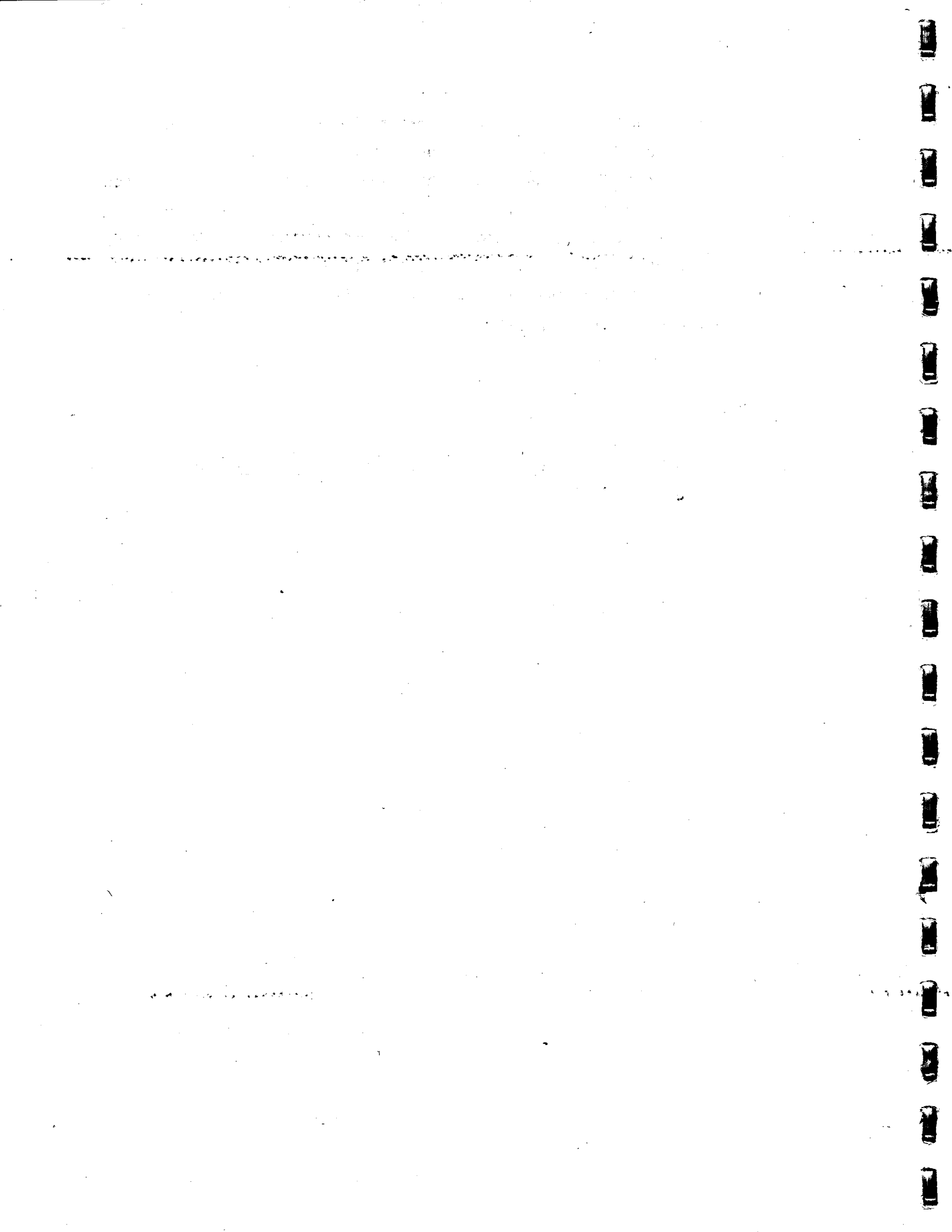



TMI-2 Self-Powered Neutron Detector and Thermocouple Data Analysis

M. E. Yancey



IDAHO NATIONAL ENGINEERING LABORATORY



Approach

- Objectives
- Constraints
- Test methods
- Results
- Conclusions

Objectives

- Evaluate the effects of the accident on the in-core instrumentation.
 - 364 Self-Powered Neutron Detectors (SPNDs)
 - 52 background detectors
 - 52 grounded junction thermocouples (TCs)
- Assess core damage.

S2 4004

Constraints

- Perform evaluation remotely
 - Limited access to containment
 - In-containment environment: radioactive contamination

S2 4003

Typical In-Core Instrument Assembly

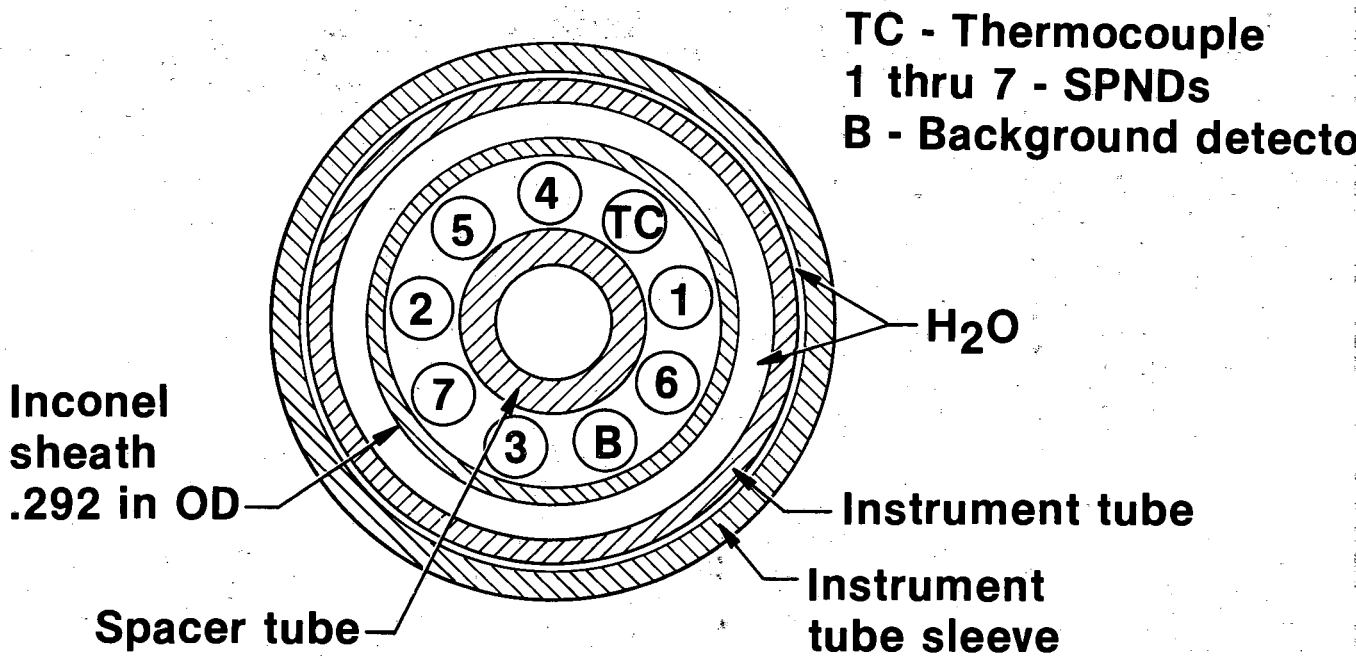

S2 10 658

Location of the In-Core Instrument Tubes

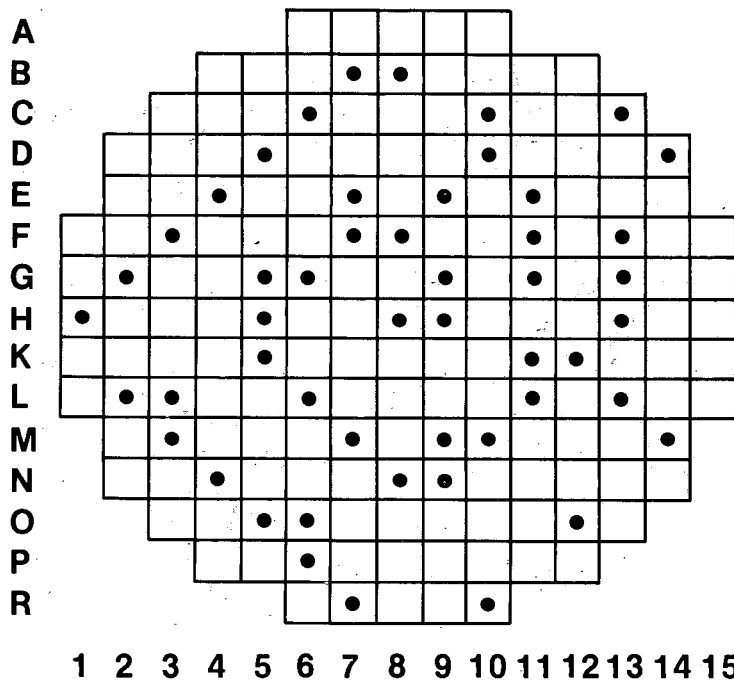

S2 10 662

In-Core Instrumentation and Cabling

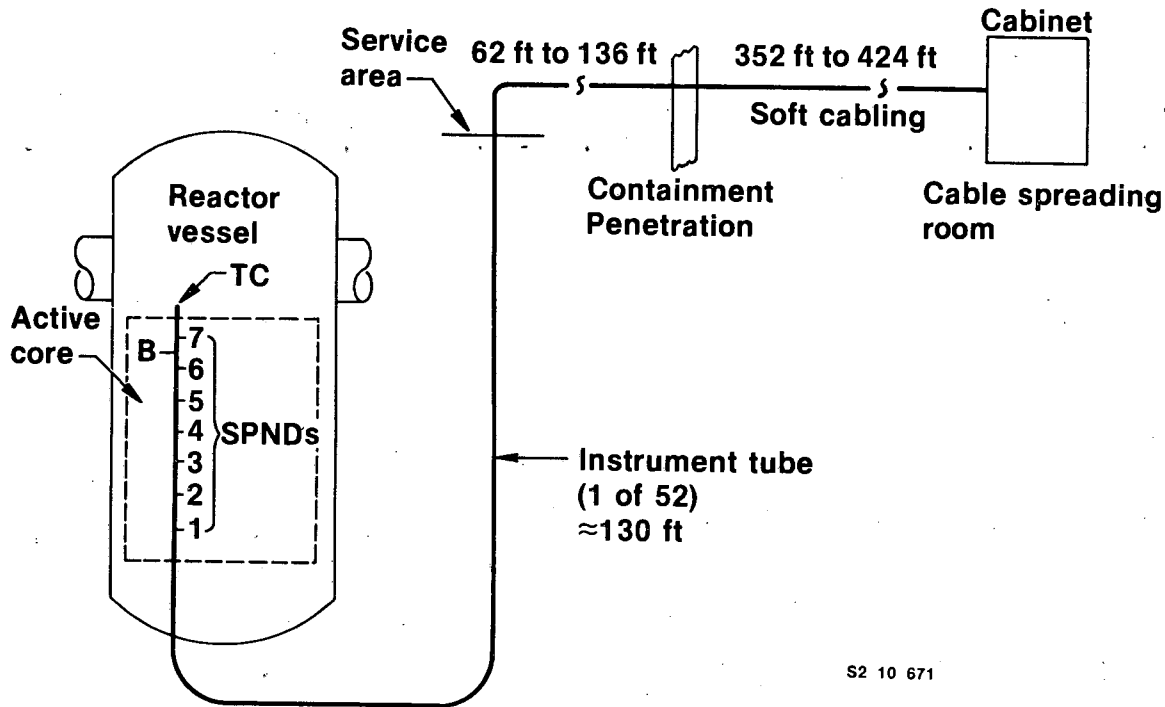

S2 10 671

Test Program

- **In situ test measurements**
 - Resistance
 - Time domain reflectometry (TDR)
- **INEL laboratory evaluation**
 - Effects of moisture on SPNDs and TCs
 - Baseline data on in situ test methods

S2 10 673

Representations of In Situ Resistance Measurements as a Function of Time

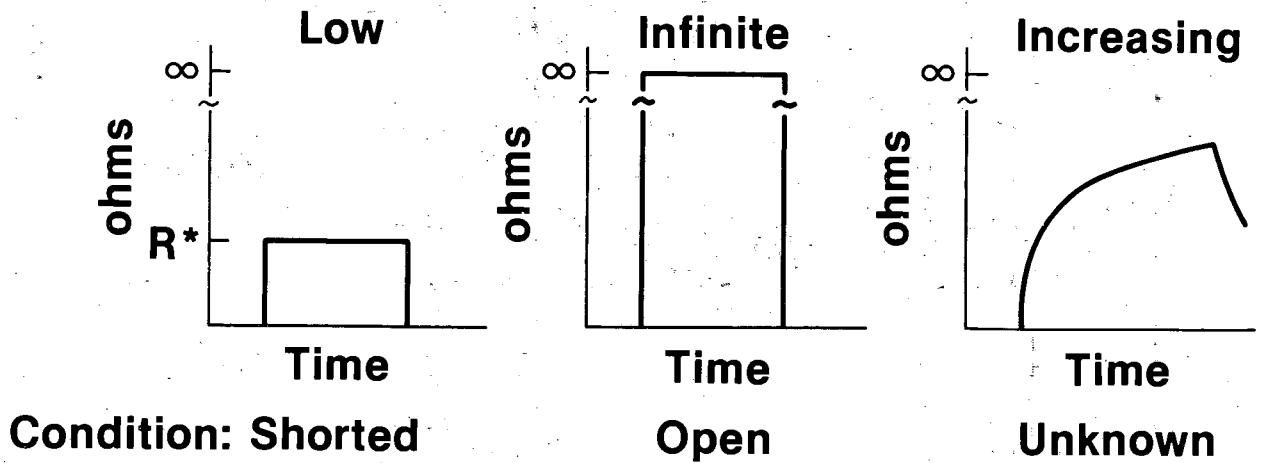

*R measured loop resistance

S2 10 665

Laboratory Loop Resistance Measurement Performed on TCs and SPNDs

	Open	Shorted
Dry	Normal SPND Abnormal TC	Abnormal SPND Normal TC
Wet	Abnormal SPND & TC	Abnormal SPND & TC

S2 10 670

TC

Results of Laboratory Loop Resistance Test

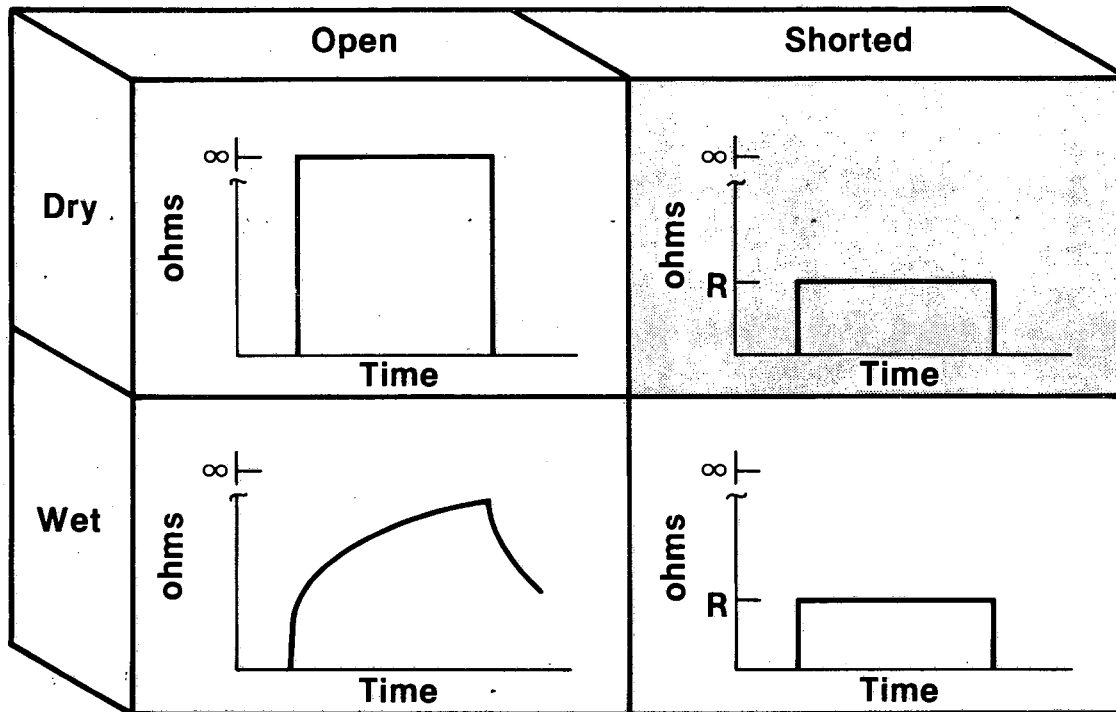

S2 10 661

SPND

Results of Laboratory Loop Resistance Test

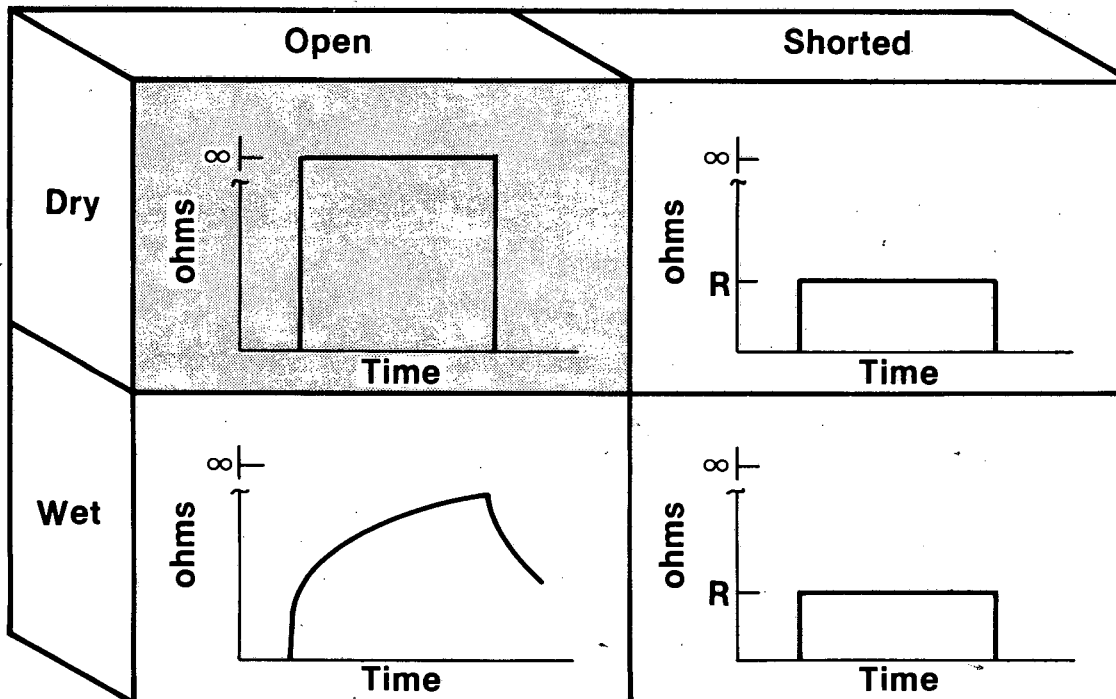

S2 10 660

Conclusions from Laboratory Loop Resistance Test for both the SPNDs & TCs

- Increasing loop resistance with time is characteristic of a wet open circuit condition
- In the shorted condition, immersion in coolant had no effect on the loop resistance

S2 10 667

Time Domain Reflectometry

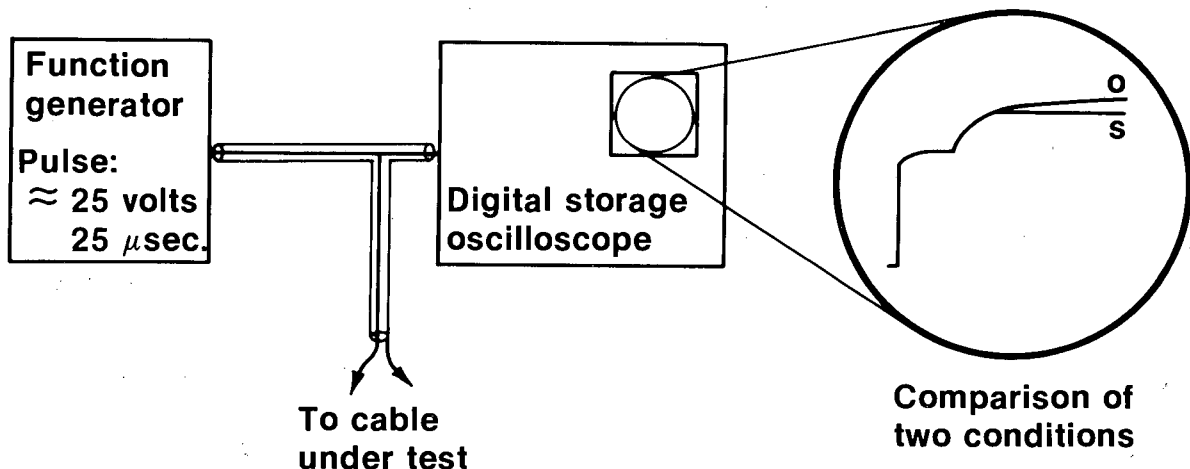

S2 4005

Selected In Situ Test Results

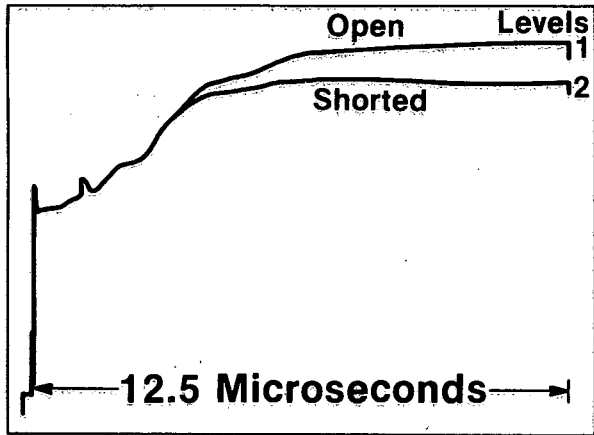

Comparison of SPND H9 levels 1 & 2

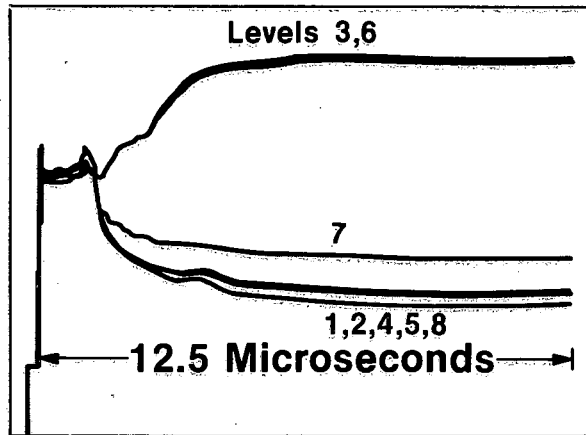

Complete set of TDR data for assembly O12

S2 10 664

Laboratory TDR Test Results (510 ft. of Cable plus 110 ft. Detector)

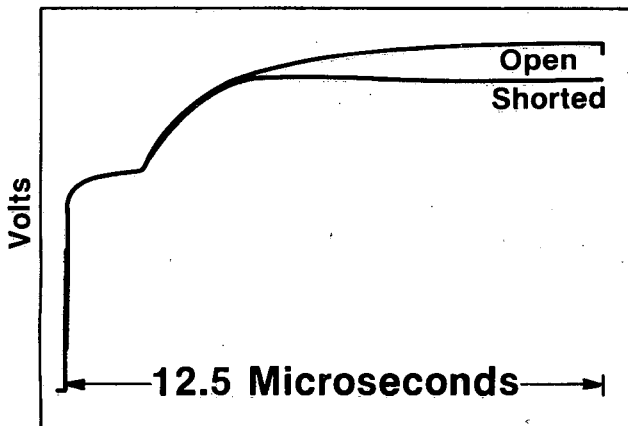

Comparison of an open and short at detector end

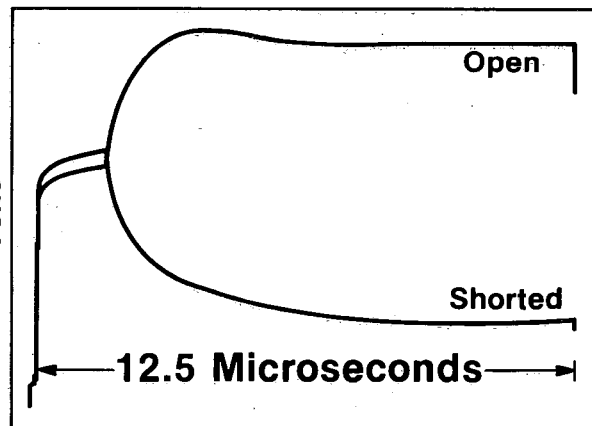

Effect of open and short at end of the soft cable

S2 10 663

Logarithmic Changes in the Normalized Resistance of the In-core Thermocouples

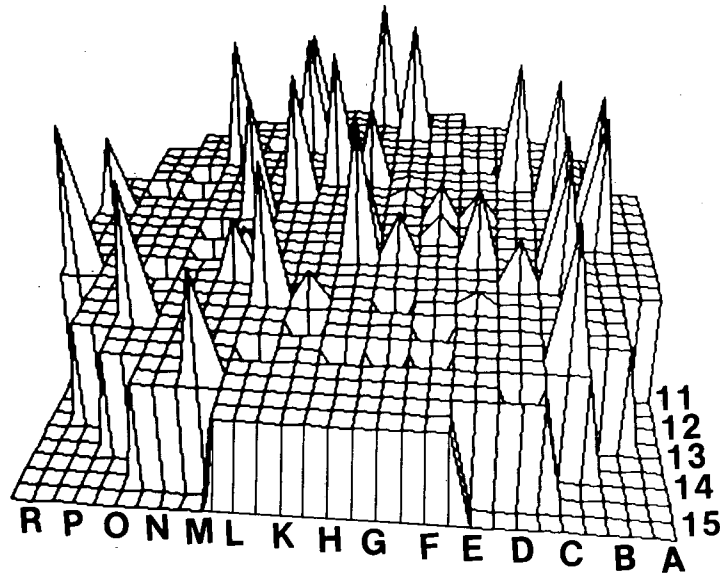

Inverted peaks - TC junction open

S2 4006

Data Analysis Summary

- SPNDs and background detectors
 - 22 open with dry insulation ($>10^9$ ohms)
 - 7 open, moisture content uncertain ($<10^9$ ohms)
 - 56 short-circuited
 - 331 open-circuit, moisture in insulation
- Thermocouples
 - 26 open junction, moisture in insulation
 - 2 open junction, dry insulation
 - 24 shorted junction, wet or dry insulation

S2 10 666

Statistical Grouping of In-Core Assemblies

	Group I Peak temp. >1200°F Avg. temp. >296°F	Group II Peak temp. <1200°F Avg. temp. <296°F	Group III Poor correlation with temperature
Total assemblies	13	20	19
% reduction in the TCs resistance	>17%	<17%	Inconsistent data
Number of SPNDs shorted	7 or 8	6 or less	Inconsistent data

S2 10 659

Three-Dimensional Plot of the Statistical Grouping

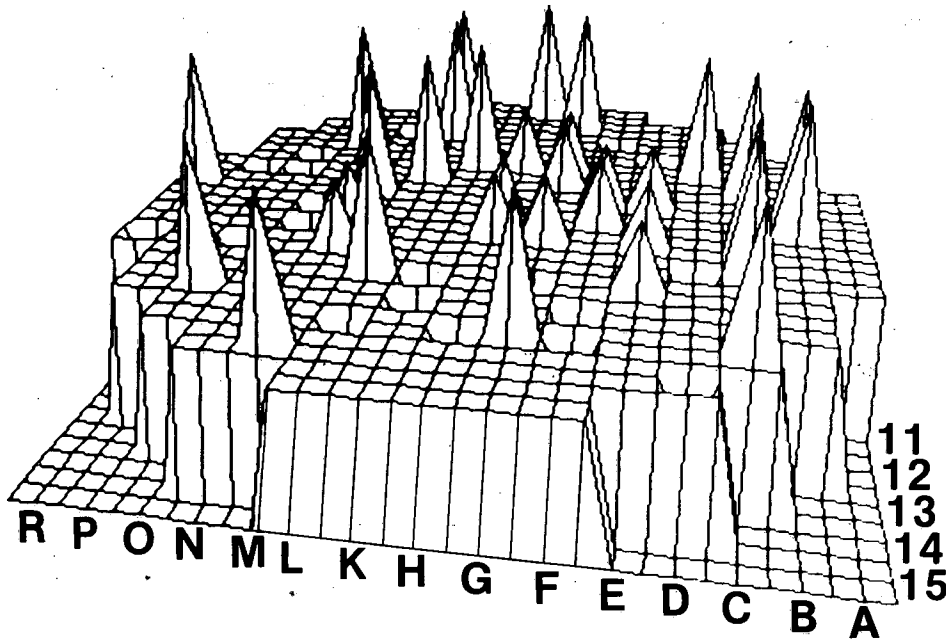

S2 10 672

Conclusions

- **Most extensive damage occurred in central area of core.**
- **Majority of the 22 operational SPNDs were in the lower regions of core.**
- **Majority of in-core detectors had moisture in insulation.**
- **All thermocouples apparently failed.**

MEMORANDUM

TO : [Illegible]

FROM : [Illegible]

SUBJECT : [Illegible]

[Illegible]

[Illegible]

[Illegible]

[Illegible]

[Illegible]

[Illegible]

[Illegible]

[Illegible]

[Illegible]

IN-CONTAINMENT RADIATION MONITORING AT TMI-2:
M. B. Murphy (Sandia National Laboratory)

1944

IN-CONTAINMENT RADIATION MONITORING AT TMI-2*

M. B. Murphy
Sandia National Laboratories**
Albuquerque, New Mexico 87185

INTRODUCTION

One of the difficulties encountered by operators during and following the March 28, 1979 accident at Three Mile Island was that of assessing the radiation levels inside containment. Before the first day was over, two of three Geiger-Muller (GM) tube area monitors had failed. Even the LOCA qualified Dome Monitor readings were (and still are) questionable. Eventually this monitor failed also. We have analyzed the failure modes of these detectors and have found that relatively simple design improvements are possible to extend the usefulness of these instruments during a LOCA. This paper discusses the failure modes of the detectors we have analyzed to date and the containment building radiation level estimates we have pieced together.

FAILURE MODES

The GM-tube detectors used for area monitoring were standard Victoreen 857-2 models which measure radiation rates of up to 10 R/hr. These detectors are well sealed and rugged, each having an O-ring seal on the metal container which houses the GM tube and

*This paper was supported by the U. S. DOE through the Three Mile Island Technical Integration Office, Middletown, PA.

**A U. S. DOE facility.

electronics. The Victoreen Model 847-1 dual ion chamber Dome Monitor is sealed inside a stainless-steel cannister and shielded by 5 cm of lead. It is capable of measuring rates of from 0.1 mR/hr to 10,000 R/hr inside the lead shield.

The stripchart reproduction in Figure 1 shows the responses of the Dome Monitor (HP-R-214) and two of the three GM tube detectors during the first 48 hours of the accident. During this time, HP-R-211 registers inappropriately low levels and HP-R-213 abruptly fails. HP-R-214, the Dome Monitor, appears to operate properly during this time, although the operators were confused about its readings because of scaling problem difficulties encountered both on the meter readout and stripchart output. Table 1 summarizes our findings regarding the approximate times and causes of failure of the various detectors.

The only common failure to these detectors (not mentioned in the table) is a multivalued readout behavior in which the detectors indicate low radiation levels when in fact the levels are quite high.^{1,2} This behavior has been traced to a combination of an unusual GM tube circuit interaction and improper transmission line matching. The other failures are related to mounting and sealing practices, quality control, and possibly an inherent GM tube design limitation (quench gas depletion). Although the Dome Monitor failure, which resulted in low radiation readings, has not been fully analyzed, it appears to have been caused by radiation degradation of a circuit component.

RADIATION ENVIRONMENT

The absence of reliable radiation measurements inside containment has made it difficult to use TMI-2 data to validate LOCA radiation type and disbursal models. We are attempting to improve this situation by using the various radiation detector stripchart recordings as well as our measurements of the total radiation doses received by each detector to draw a composite rate vs time curve. Although at this writing our data is somewhat incomplete, our first estimates are that at the 305 foot level near the personnel hatch the peak rate reached approximately 10,000 R/hr and remained there for about 6 hours. The sprays then reduced the level to approximately 1000 R/hr, from which a normal decay to 1 R/hr occurred over a period of months.

We have found it to be possible to estimate the total doses of gamma radiation received by the various detectors by comparing the degradation of bipolar transistor current gains with those exposed in the laboratory to known radiation levels. It is necessary to both characterize the transistors with regard to known doses and then account for bias and annealing effects. We have compiled supportive data of this method by examining MOS transistors from other TMI instruments and elastomeric materials. Using this approach we estimate that HP-R-211, HP-R-212 and HP-R-213 received total gamma doses of 2.5×10^5 R, 4.5×10^5 R, and 1×10^6 R, respectively.

CONCLUSIONS

The experience at TMI-2 clearly demonstrates the need for improvements in radiation measurement during a LOCA. Since a number of existing nuclear plants use similar equipment, the TMI findings are directly applicable.

-
1. Michael B. Murphy, Frank V. Thome, "TMI-2 Instrument Analysis Results", American Nuclear Society Winter Meeting, San Francisco, November 29 - December 3, 1981.
 2. Michael B. Murphy, Geoffrey M. Mueller, Frank V. Thome, "Examination Results of the Three Mile Island Radiation Detector HP-R-211", GEND-014, October, 1981, U. S. Department of Energy.

CONTAINMENT RADIATION MONITORING AT TMI-2

PRESENTATION BY
MICHAEL B. MURPHY
SANDIA NATIONAL LABORATORIES
1982 ANS WINTER MEETING
WASHINGTON D.C.

Radiation Monitoring

AREA RADIATION MONITORS TMI-2

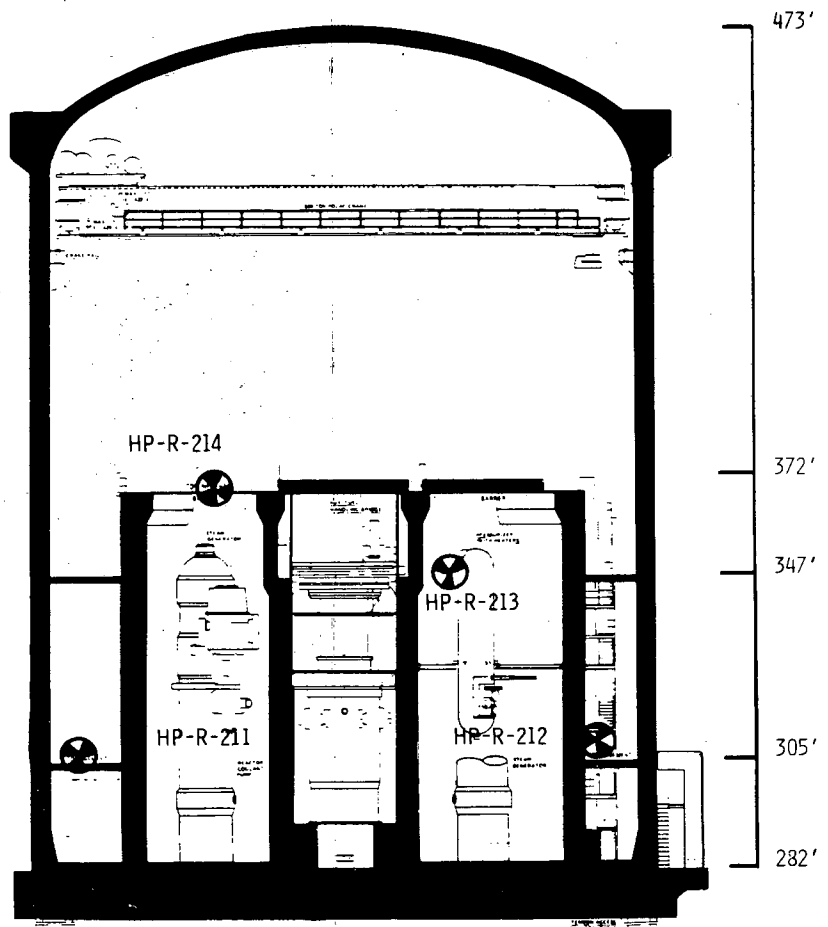

Radiation Monitoring

RADIATION DETECTOR FAILURES

Detector	Type	Failure Time	Failure Cause
HP-R-211 ¹	GM	1-10 Hours	Transistor - HV overstress due to unsealed connector backshell
HP-R-212 ^{1,2}	GM	218 Days	Total dose quench gas depletion in GM tube
HP-R-213 ¹	GM	10 Hours	Fractured GM tube
HP-R-214	ION	100-1000 Hours	Electrode resistive path due to humidity
		100-1000 Hours	MOS Transistor radiation degradation
		> 10,000 Hours	Electrolytic Capacitor failure

Notes: 1. All GM detectors had multivalued outputs - radiation degradation/impedance mismatch
 2. Unit turned off early in accident - activated 88 days later

MULTIVALUED RESPONSE

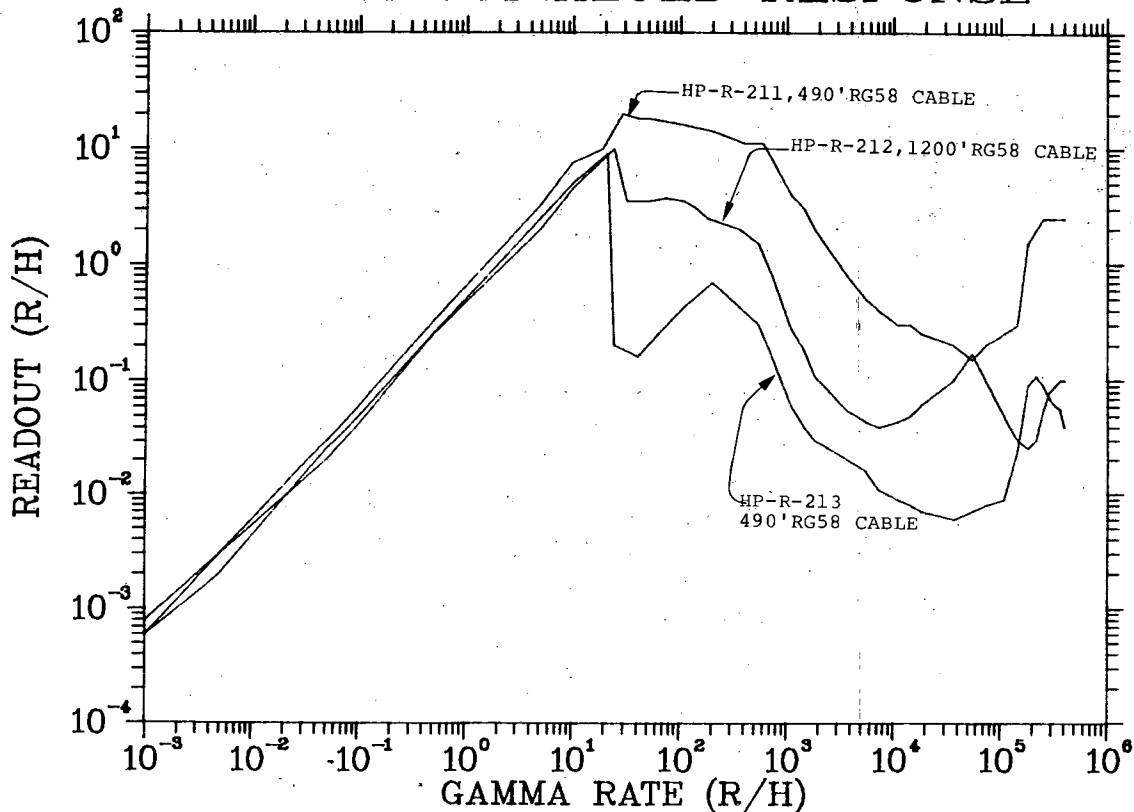

Radiation monitoring

DOME MONITOR HP-R-214

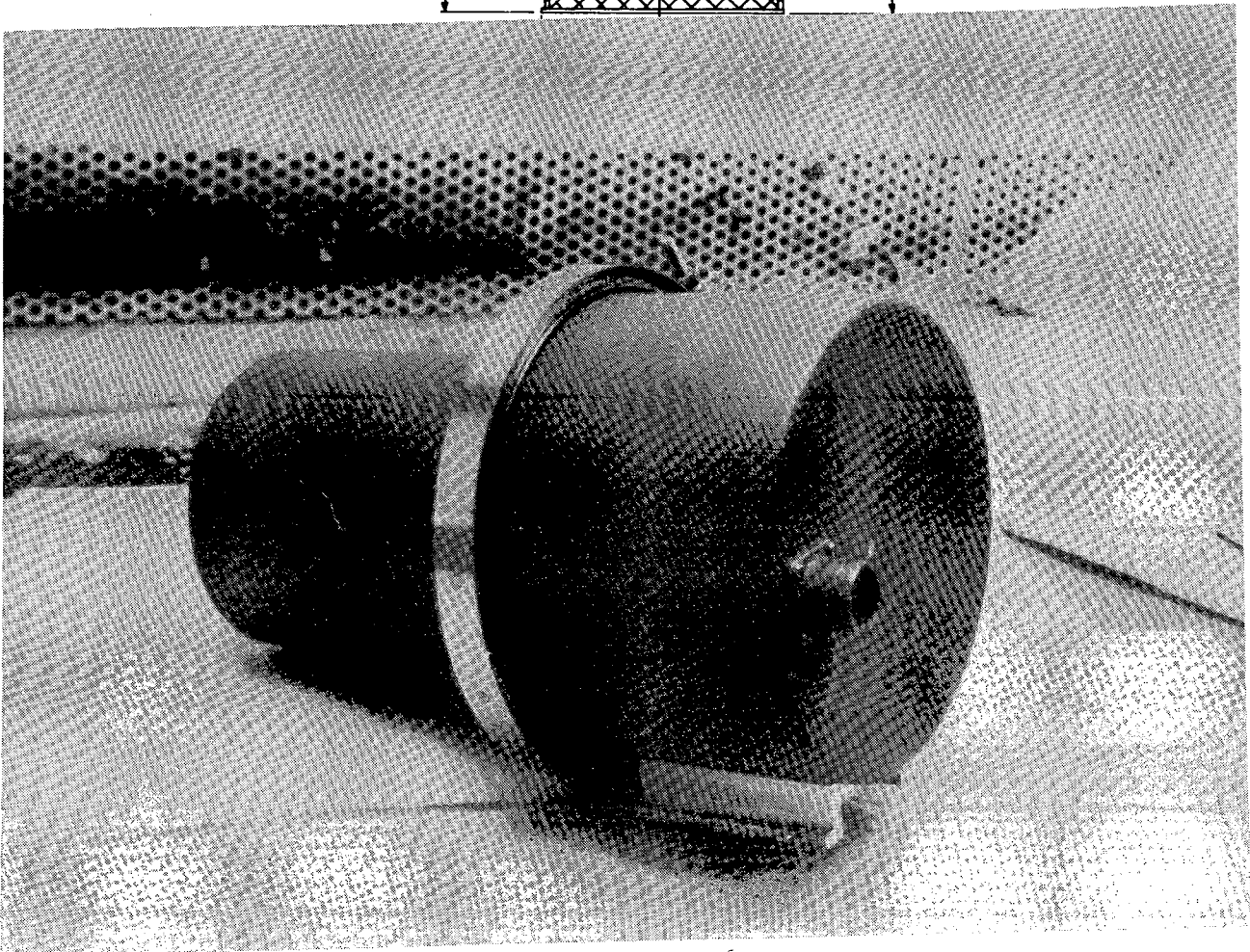
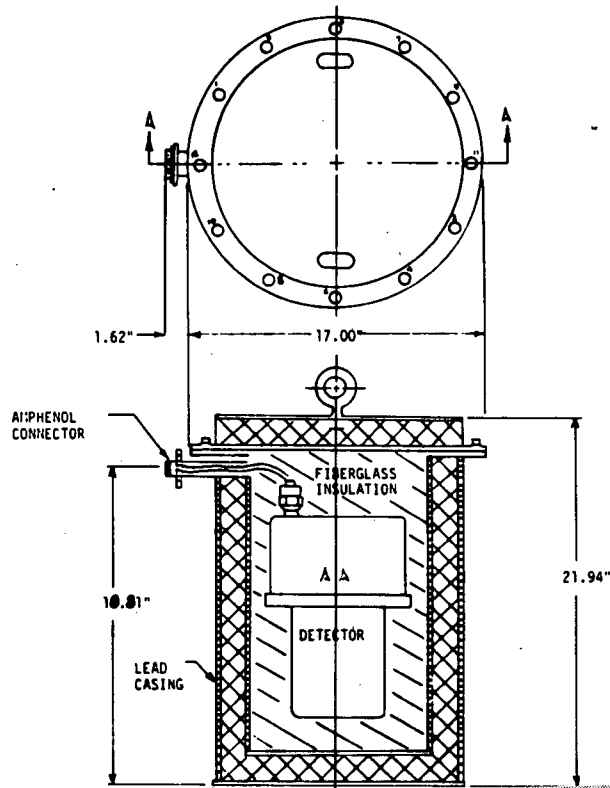

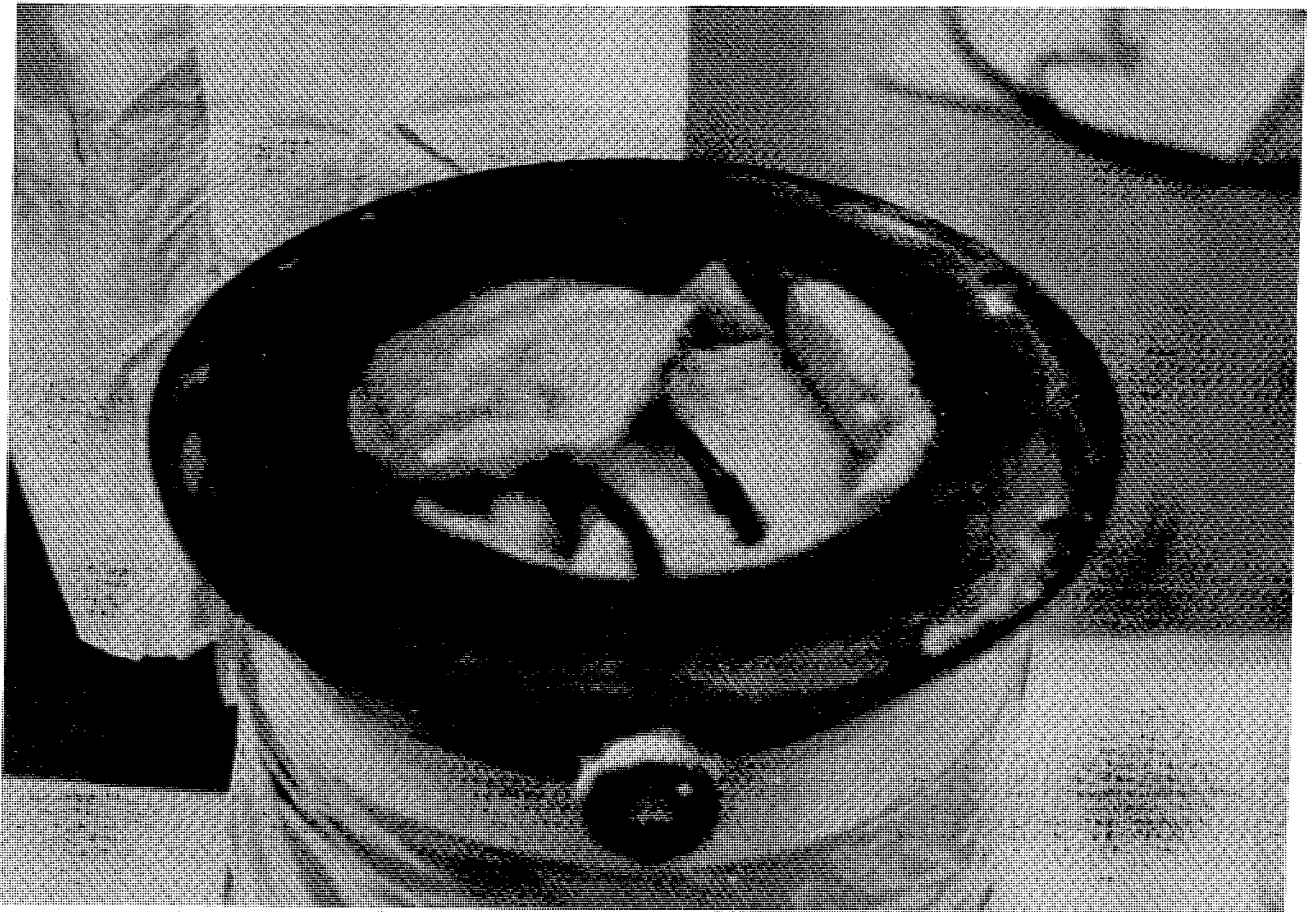

DOME MONITOR STRIPCHART

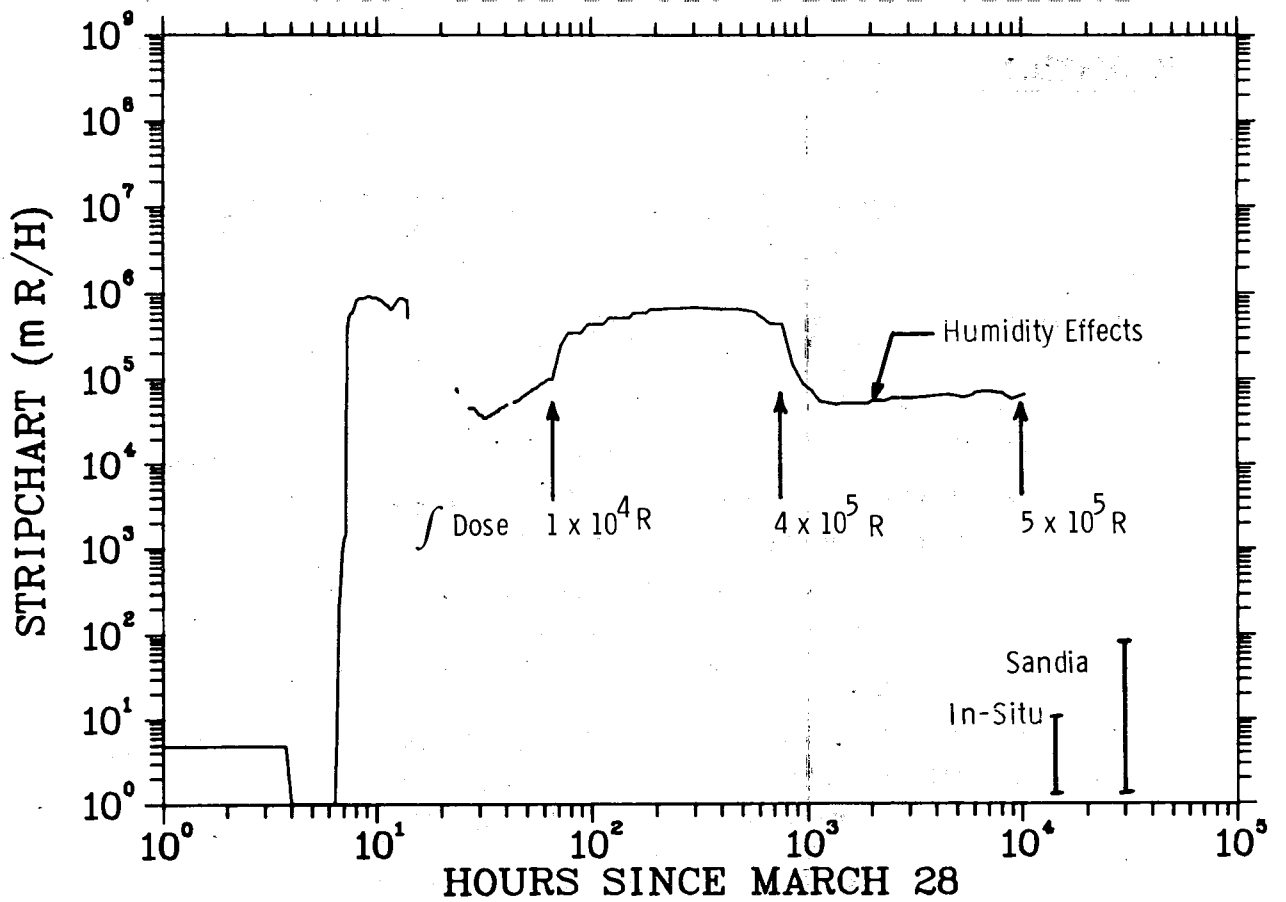

HP-R-214 READOUT

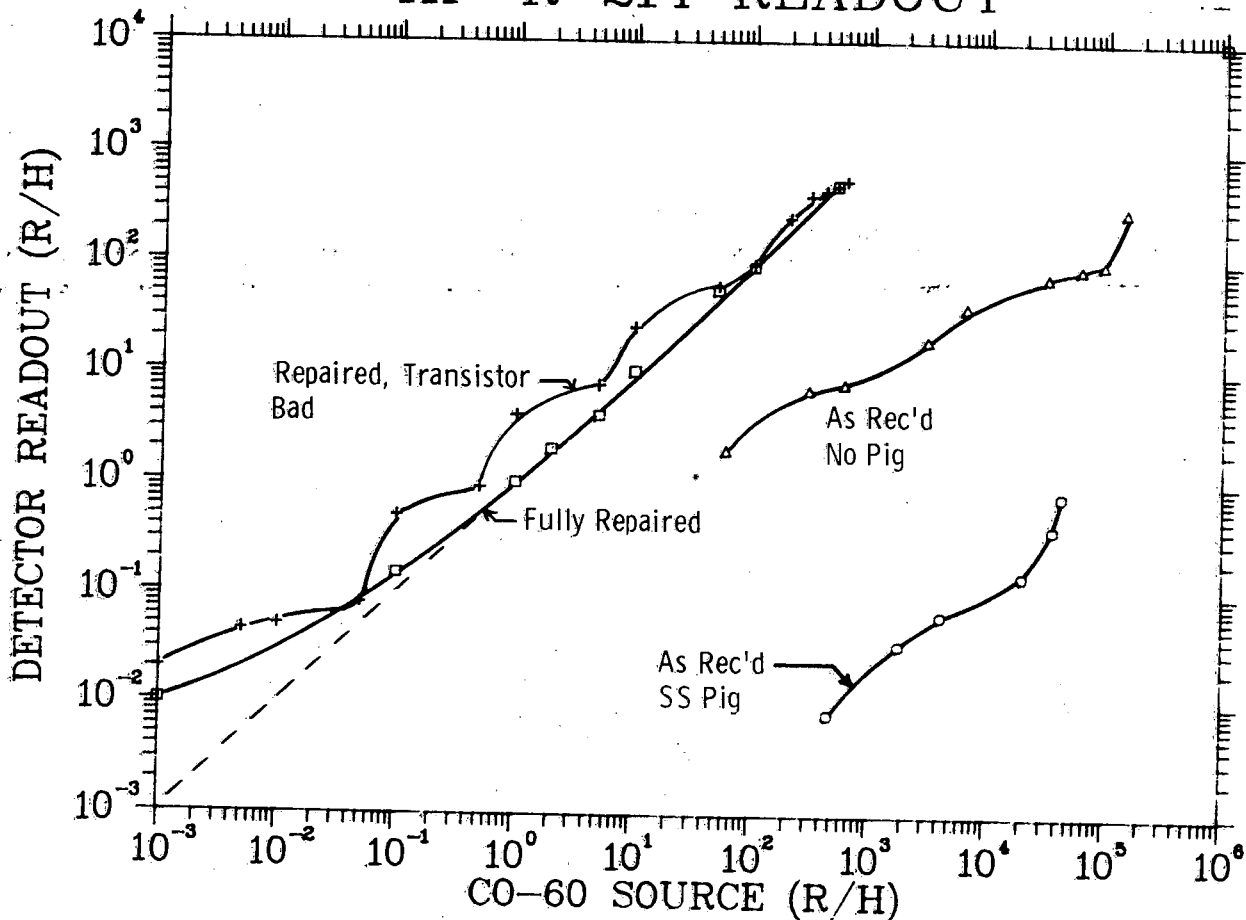

RADIATION MONITORING

DOME MONITOR FINDINGS

● PRESSURE VESSEL SEAL

1. Holes In Outer SS And Pb (1.4, 0.3 cm Dia)
2. Vessel Leaked Around Gasket (Exponential $t = 3.0$ Hrs)
3. Detector Case Leaked Through Bracket Holes (Exponential $t = 12.5$ Min)
4. Vessel Internal Contamination (CS-137)

Bottom	1.4 E-1	uCi/Swipe
Lid	1.9 E-2	uCi/Swipe
Sides	3.1 E-3	uCi/Swipe
5. Boron Detected (200 ug/sample)
6. Fiberglass Activity (CS-137)

Outer Bottom	340016	counts/600 sec
Mid Center	246	counts/600 sec
Upper Top	5133	counts/600 sec

LEAK RATES (AIR)

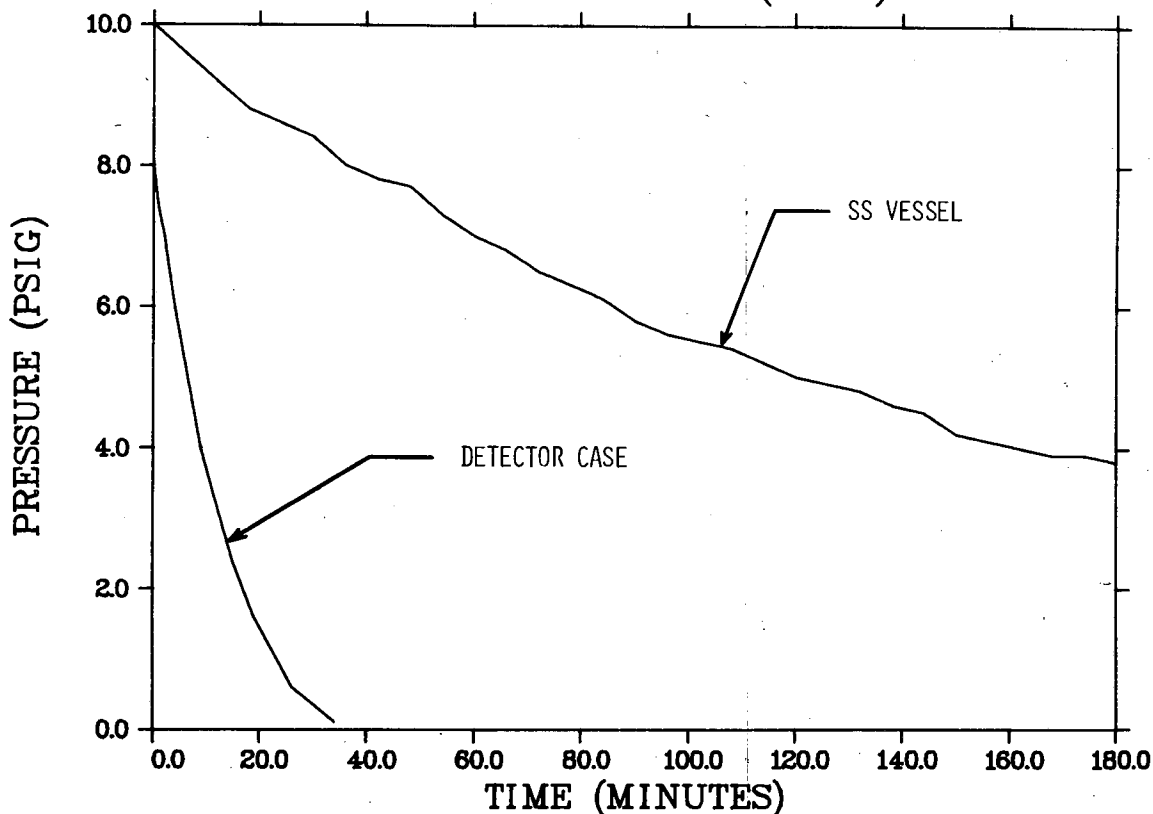

RADIATION MONITORING

DOME MONITOR FINDINGS

● FAILURE MODES

1. Humidity Induced Resistive Paths From Chamber Electrodes To Grounded Guard Rings

- 10^{10} To 10^{12} Ohms Is Sufficient To Give High Readout
- DC Feedback And Reed Switch Operation produces Phantom Signal
- Liquid Water On Detector Electronics When Case Opened
- Humidity Entry Caused By Unsealed Bracket Mount

2. Electrolytic Capacitor C17 Failure

- Electrolyte Leakage Resulted In Reed Switch Inoperability
- Corroded Q14 Collector Lead Open
- Caused Detector Failure After 416 Days

3. MOS Transistor Q15 Failure

- Caused Unstable/Erroneous Low Range Readings
- Probable Cause - Radiation Degradation 3N163 MOS Transistor

HUMIDITY EFFECTS

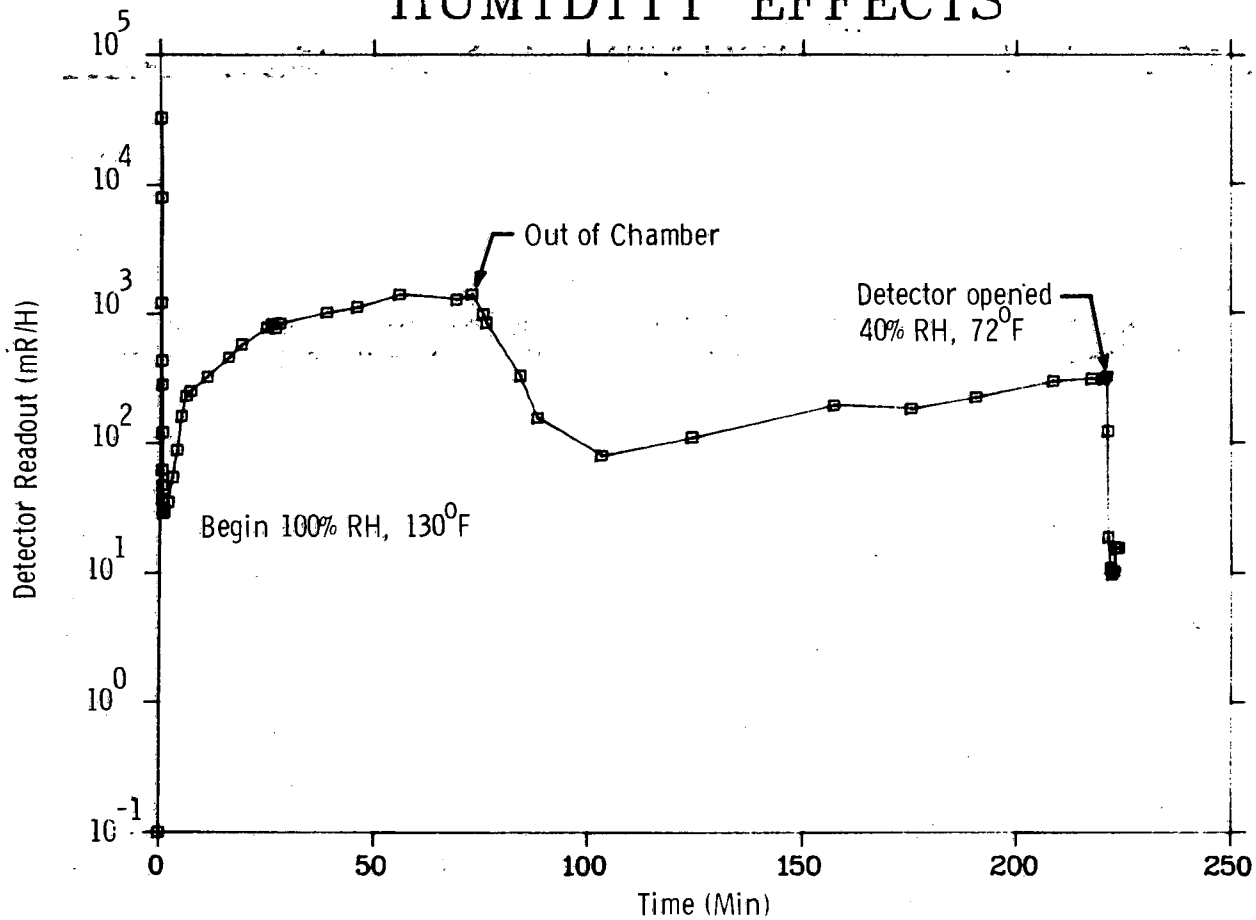

Radiation Monitoring

DETECTOR PREAMP EQ. CIRCUIT

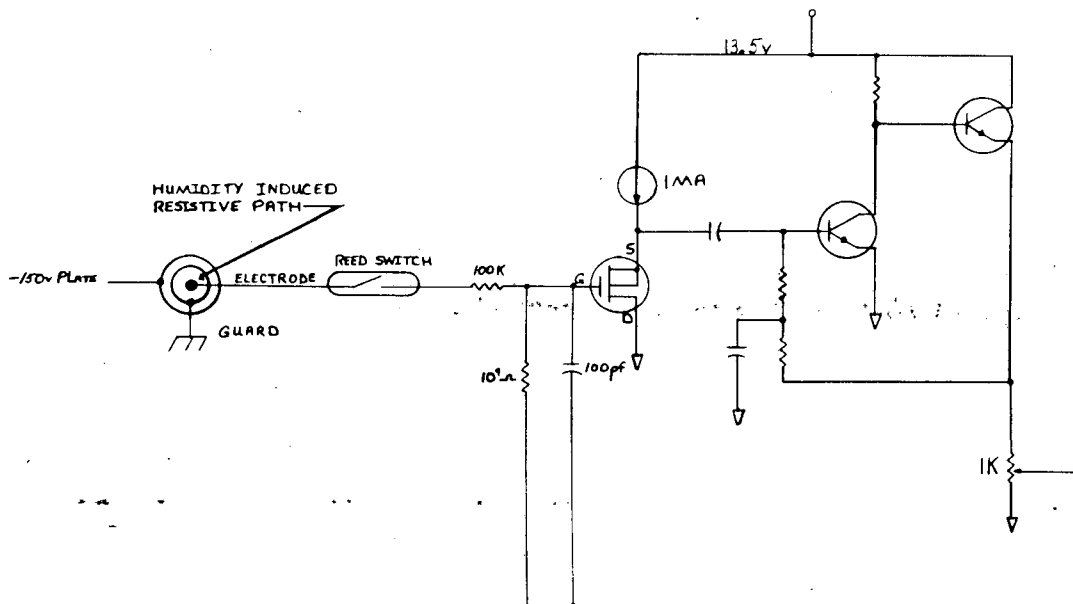

HUMIDITY EFFECTS

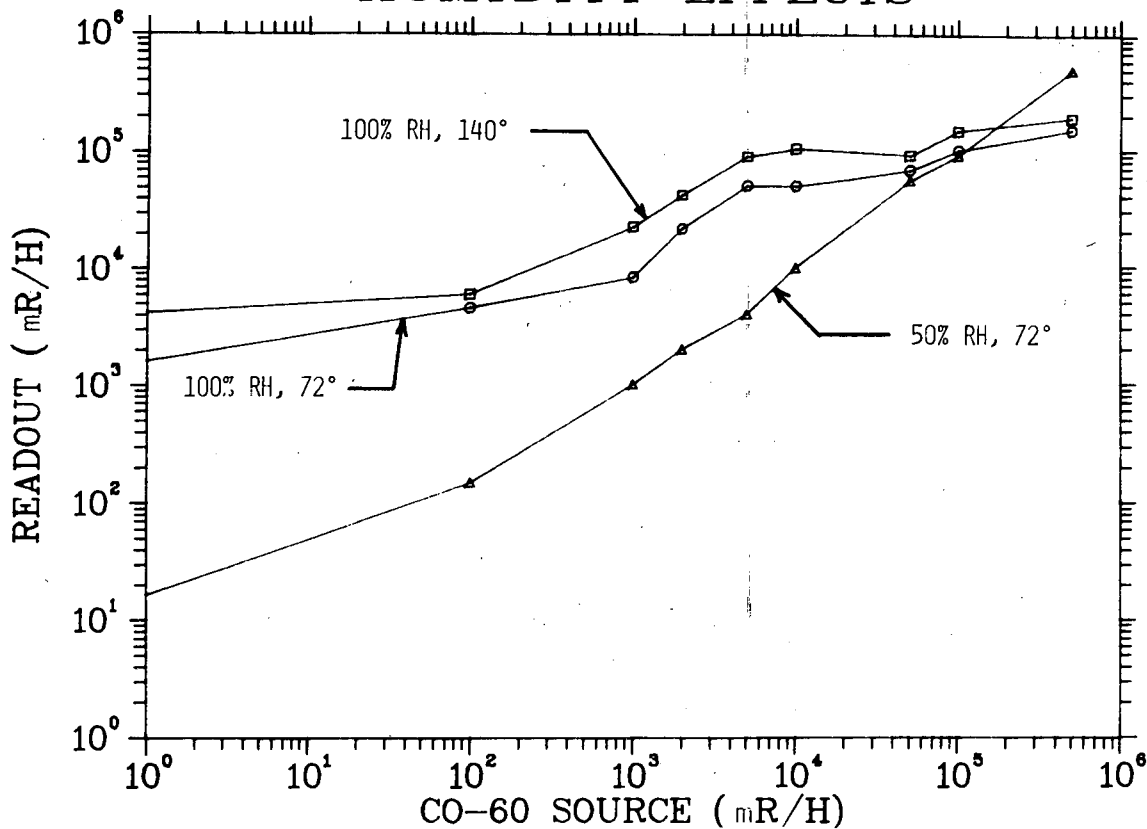

RADIATION MONITORING

DOME MONITOR FINDINGS

● CONCLUSIONS

1. **Ratemeter Readout Was Accurate**
2. **Stripchart Radiation Reading (Corrected) Probably Accurate To 100 Hours**
3. **Humidity, Dissolved Contaminants And Radioactive Gas Leaked Into Vessel During 10 Hours of 4PSIG Overpressure**
4. **Most Contaminants Condensed On Inner Vessel Walls And Ran To Bottom**
5. **Internal Contaminants Probably Did Not Contribute Significantly to Radiation Readout**

RADIATION MONITORING

DOME MONITOR

● AREAS BEING INVESTIGATED

1. Calculate Effects Of Internal Contaminants
2. Measure Void Around Lead And Calculate Effect
3. Corrcct Readout Inside Lead
4. Perform Photon Transport Calculation Through Lead
5. Estimate Energy Dependence of Detector
(Efficiency vs Energy)

RADIATION MONITORING

GAMMA DOSE ESTIMATES

EQUIPMENT TAG NO.	ELEVATION (FEET)	MATERIAL ANALYZED (NO.)	DOSE ESTIMATE (X10 ⁵ RADS)	RANGE (X10 ⁵ RADS)
HP-R-211	305	TRANSISTORS (6)	2.5	0.85 - 5.1
		TEFLON SLEEVE (2)	2.0	0.7 - 6.0
HP-R-212	305	TRANSISTORS (6)	4.5	1.5 - 11.0
HP-R-213	347	TRANSISTORS (6)	9.9	3.9 - 18.5
HP-R-214 (INSIDE Pb SHIELD)	372	TRANSISTORS (10)	2.83 ¹	2.1 - 4.5
HP-R-214 CABLE (OUTSIDE Pb SHIELD)	372	SILICONE INSULATION (20)	79 ²	71 - 86
		MYLAR FILM (4)	68 ²	20 - 200

1. DATA INCOMPLETE
2. GAMMA AND BETA COMBINED DOSE

2N3643 FAIRCHILD ACTIVE 100UA

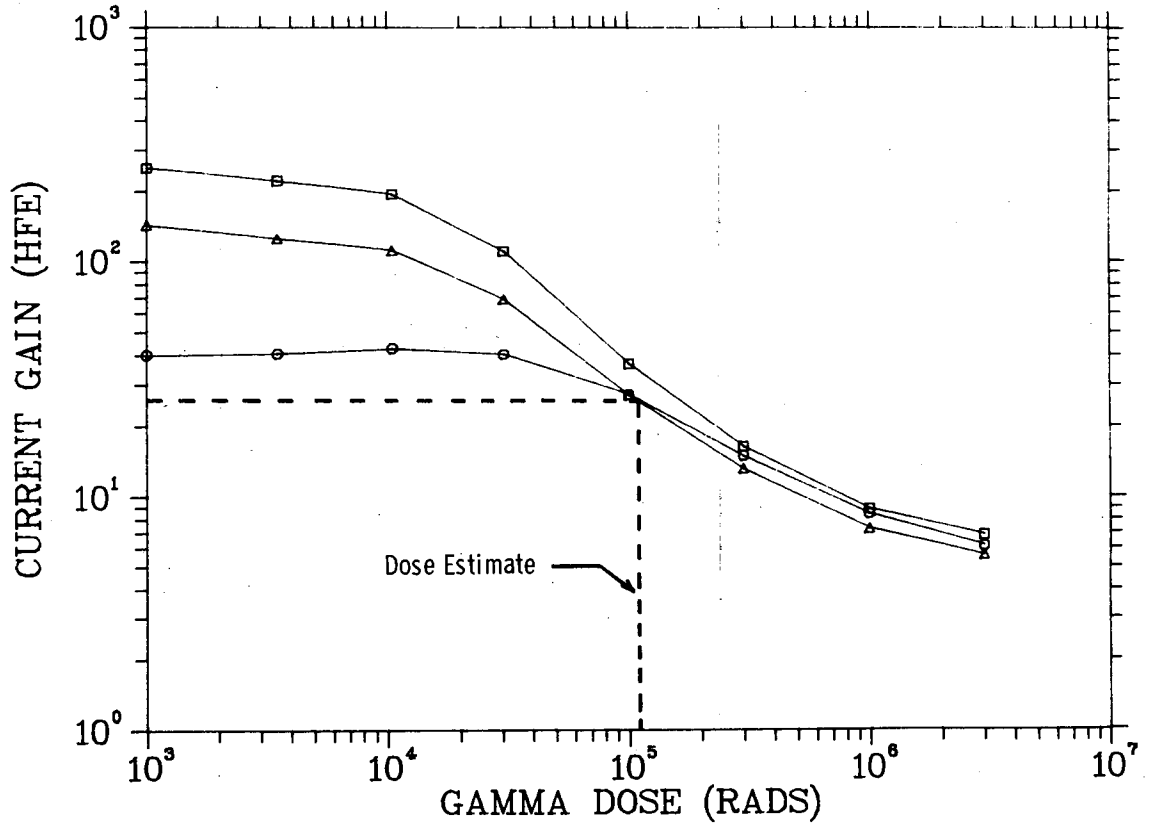

SILICONE DEGRADATION

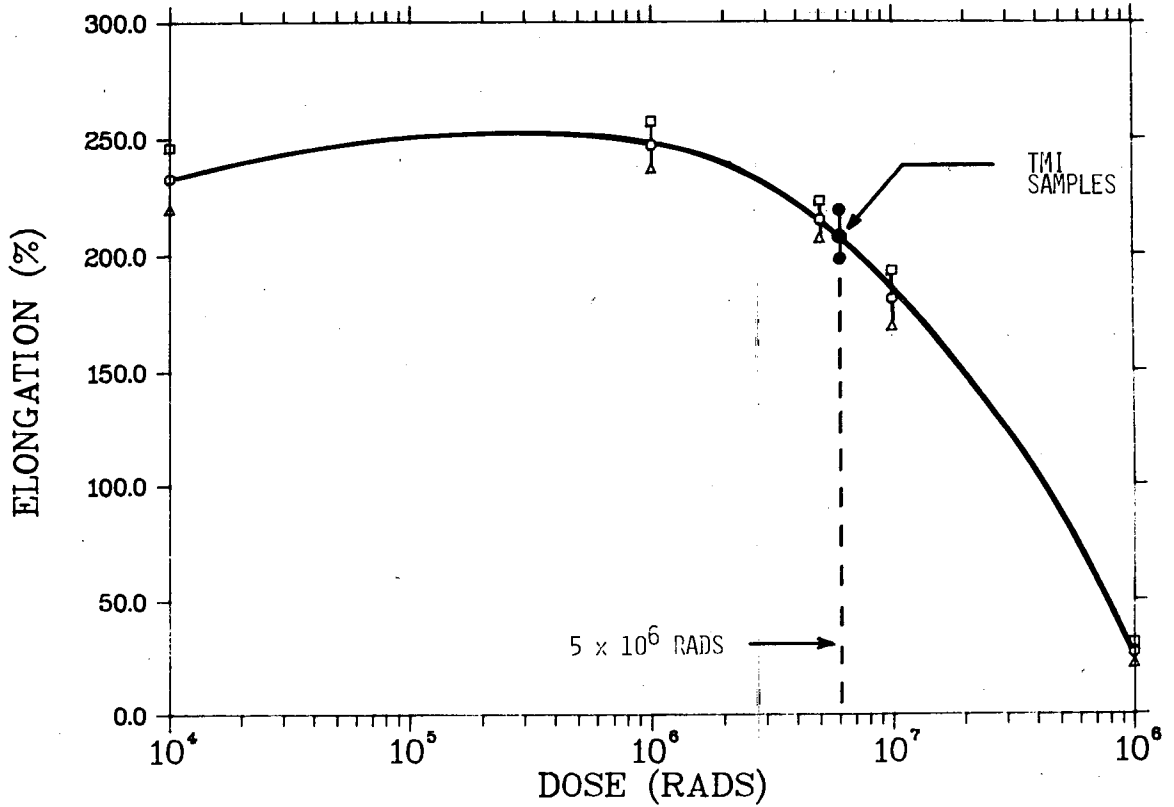

Radiation Monitoring

GENERAL RECOMMENDATIONS

- CONFORMALLY COAT PRINTED WIRING BOARDS
- POT CONNECTORS
- DO NOT USE MOS TRANSISTORS
- REMOVE ELECTRONICS FROM CONTAINMENT

RADIATION MONITORING

LESSONS LEARNED

- TMI-2 Demonstrates The Need For Improvements In Radiation Measurement During A LOCA
- Radiation Measurement Systems In Other Existing Plants Should Be Examined/Retrofitted
- Equipment Used In Containment Should Undergo More Extensive Environmental Testing Prior To Installation

PRELIMINARY EXAMINATION OF MINAC FOR TMI-2
DEBRIS EXAMINATION
M. E. Lapidès (Electric Power Research Institute)



1.0 Summary

MINAC, a portable, high-energy radiographic source⁽¹⁾ has been utilized in various in-containment reactor component inspections and is under development as both a higher output and real-time system. This paper is responsive to a request to examine the use of MINAC for debris location at TMI-2 and considers: (a) detection sensitivity, (b) influence of radiation background and fuel concentration, and (c) advanced development. When this work was performed (and currently) few data were available as to radiation backgrounds. Hence definitive answers as regards TMI-2 usage cannot be provided. However, information is provided to define prospects and limitations.

2.0 Background

MINAC is a miniaturized linear accelerator, radiographic source currently operating in the 3-4 MeV range and in process of being upgraded to 6 MeV as real-time radiographic system. If we assume a nominal half value layer (HVL) of one inch of steel, an output of 100 R/min/meter and the requirement to deposit 2 rads on film to get 0.5-1% thickness-density detectability, the exposure time at these conditions is:

$$1) \quad \theta \cong 0.02(2^T) x^2$$

The dose at the film is:

$$2) \quad 6000/2^T x^2$$

where:

θ = exposure time (minutes)

x = source to film distance (meters)

T = equivalent steel thickness of section being radiographed (inches)

These data are shown graphically in Figure 1. With present equipment the dose at the film can probably be increased by ~20% and the exposure time halved

MINAL 3 NOMINAL
RADIOGRAPHIC
PERFORMANCE @ 1 METER

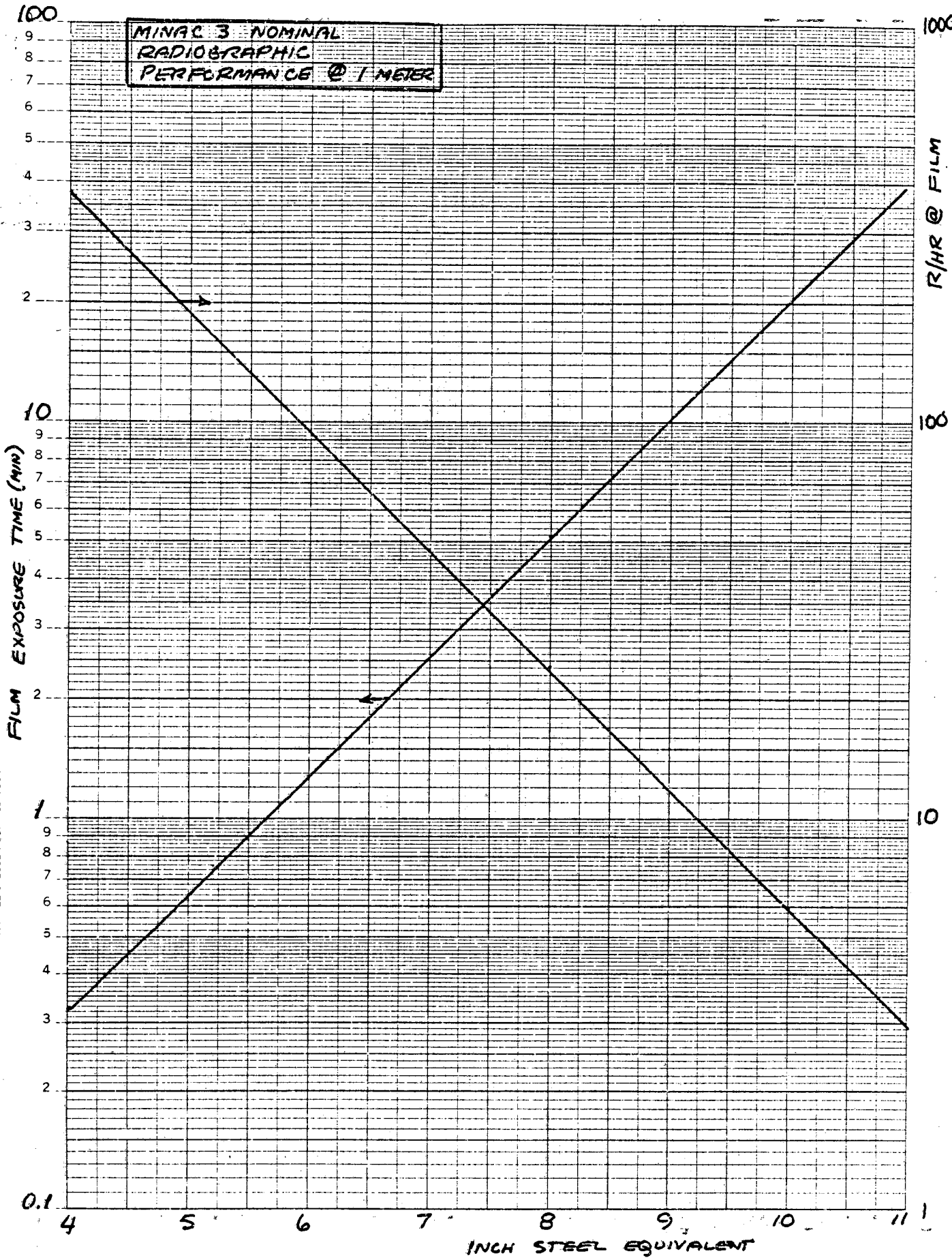

... KODAK SAFETY FILM CO. MADE IN U.S.A.

R/HR @ FILM

100

10

INCH STEEL EQUIVALENT

dependent on debris characteristics and experiments. If the R/hr at the film exceeds the background level by a factor of 5 or more, high sensitivity radiography is feasible.

3.0 Scope of Work: EPRI has undertaken a preliminary assessment of topics which could relate to TMI-2. At initiation (and currently) we have no data on radiation backgrounds except as published in GEND 018 (1980) values of 0.05-45 R/hr; energy unspecified. Work includes: (a) assess prototypic sensitivity with film, (b) assess prototype sensitivity and with a filmless system, and (c) indicate potential of ongoing R&D.

3.1 A brief experiment was run to assess sensitivity looking at UO₂ pellets through 3" steel and 19" water (approximately 5.5" steel) at approximately half the exposure times noted in Figure 1. Metal spheres wrapped in plastic sheeting were used to simulate broken pellets. Disaggregated spheres down to about 0.015" thickness could be detected demonstrating better than 1% density sensitivity (Polaroid of film attached).

3.2 Preliminary experiments have also been run with a real-time system which suggest an approximate 2% density sensitivity with about 10-second integration time. These results are obviously equipment-dependent, but correct in trend, i.e., there should be a substantial reduction in exposure time required at the expense of some loss in sensitivity.

3.3 Per GEND 018 the effective steel thickness of the largest insulated pipe of interest is approximately 10.7" as a double-wall shot with a source to film distance of 51". With the present MINAC this is approximately a one-hour exposure time; the R/hr at the film is about 2. Without knowing fields and true spatial constraints it is difficult to assess MINAC value, but the probable expectation is no better than marginal based on background.

3.4 A 6-Mev MINAC head is presently in construction which will increase MINAC output by ~3 and HVL by ~20%. This will reduce exposure time noted in 3.3 by about a factor of 10 and raise the R/hr at the film to about 20. This becomes a potentially useful system which also offers the prospect of providing an independent signature of uranium debris from photoneutrons, which is being investigated.

3.5 Once R fields (and their energy content) are known or provided we will aim at specifying a filmless system with respect to application range and sensitivity. Referenced to GEND 018 expectations it seems practically doubtful that the target sensitivities of gamma counting for UO_2 can be achieved in all piping systems. However, MINAC may well be able to establish form, shape and identify nonuranium in better or complementary fashion, contingent on radiation fields defined. The nominal system recommended would be the 6-MeV units with a real-time detector which can be fully remoted (see 3.6).

3.6 The nominal 6 MeV MINAC appears to have sufficient energy tuning range capability to provide a substantial neutron return (via photoneutrons) from uranium-bearing debris. This alternate signature capability is currently being investigated.

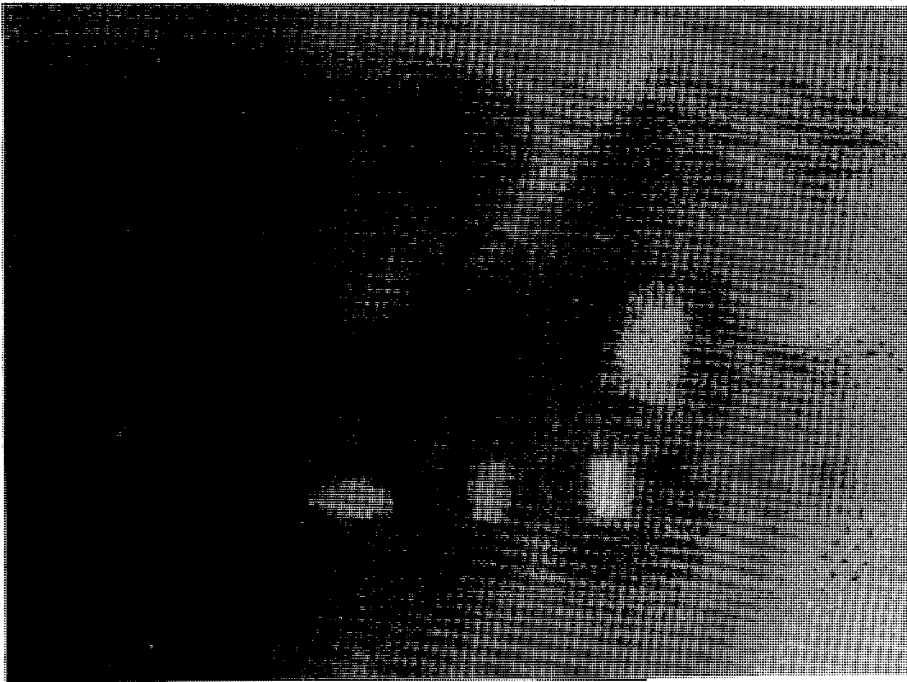

Polaroid of Section 3.1 Radiograph of Pellets and Simulated Debris (Circle shows 0.015 in thickness of debris)

Special Considerations

If fuel is the dominant source of radiation in TMI-2 piping, the expected applicability of MINAC would be expected to be of the following form (as a radiographic source)

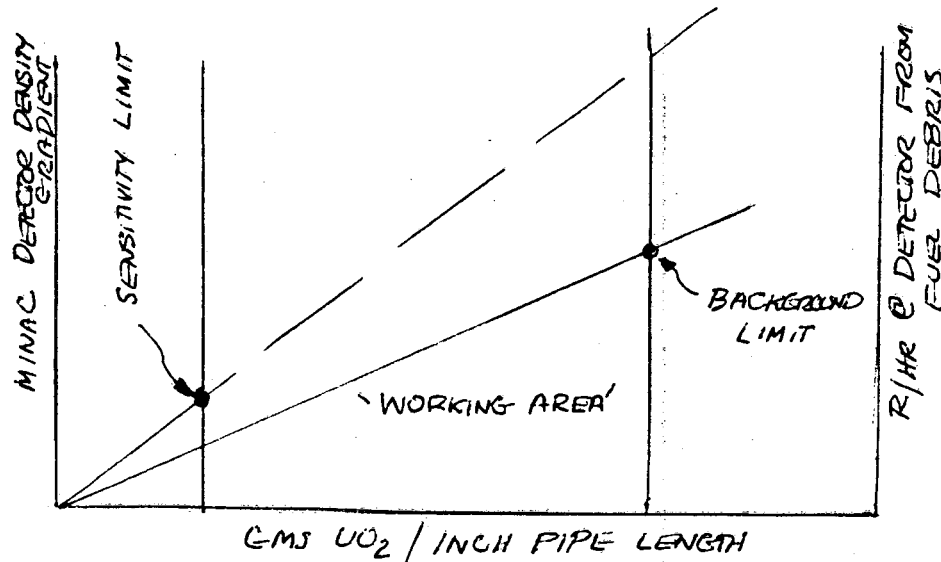

To roughly quantify this illustration, GEND 018 data (P19) were utilized to assess a hot leg pipe condition under the assumption that 137 Cs was the dominant source of fuel radiation in a configuration as shown

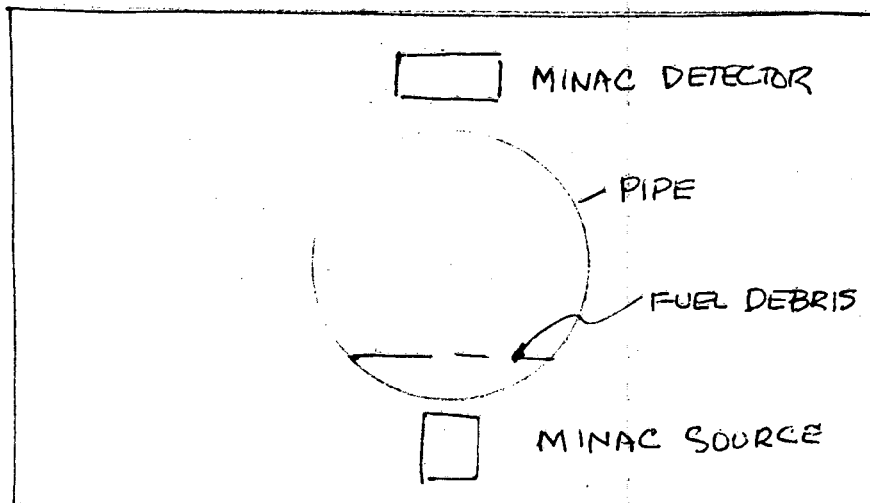

Correcting the stated cesium flux for position and for the fact that its radiation is attenuated by only a single pipe wall cross section (in comparison to a double wall situation for MINAC) yields a contribution of 3.3×10^{-3} R/HR per gram of U at the MINAC detector. Assuming MINAC 6 (sec. 3.4) yielding 20 R/hr at the detector 60 grams of UO_2 would provide a 10% background noise, 120 grams would provide a 20% limit before fogging would inhibit radiographic detection. Further, assuming a 1% density sensitivity and a UO_2 disaggregated density roughly the same as steel, the minimum thickness of debris detectable is about 0.11" which equates to a range of 2-30 gms of UO_2 dependent on distribution; the former figure representing the approximate lowest detectable item.

Technical Brief

Minac: New Capability for Radiographic Inspection in Power Plants

Mandated and diagnostic in-service radiographic inspections of power plant components require reliable, high-intensity radiation sources that are convenient to transport, safe and easy to operate, and adaptable to the plant environment.

In the past, radioactive isotopes—usually cobalt or iridium—were the only practical radiation sources for in-plant inspections. But the radiation intensities available in isotopic radiography are not high enough to make the required thick-section penetrations in reasonable exposure times. Moreover, radioactive materials are frequently difficult to handle.

In their checks for hidden structural flaws, component manufacturers depend on high-energy accelerators to achieve the radiation intensities needed to penetrate foot-thick steel sections. These large, permanently installed accelerators (most weigh nearly 2 tons) provide a quality of inspection that has been beyond the capabilities of isotopic radiography.

Minac is a portable, high-energy, miniaturized linear accelerator developed by the Schonberg Radiation Corporation and EPRI. It packs the versatility and power of the large stationary accelerators into a compact system that is especially designed for in-plant service.

The development of the Minac system was begun after EPRI studies verified the feasibility of using higher-frequency components (X-band instead of S-band) and other design innovations to assemble

and package a small linear accelerator. In its present configuration, Minac is five times smaller than the conventional accelerators used by component manufacturers.

The Minac system is made up of three major components: a control console, a modulator/power supply, and a radiation head. Miniaturizing the radiation

head was the principal design problem. The accelerator and many associated high-power, high-voltage components were eventually contained in a head a little over 3 ft³. The head weighs about 225 lb, the complete system about 700 lb.

In its first field application (May 1981), Minac was used to make mandated

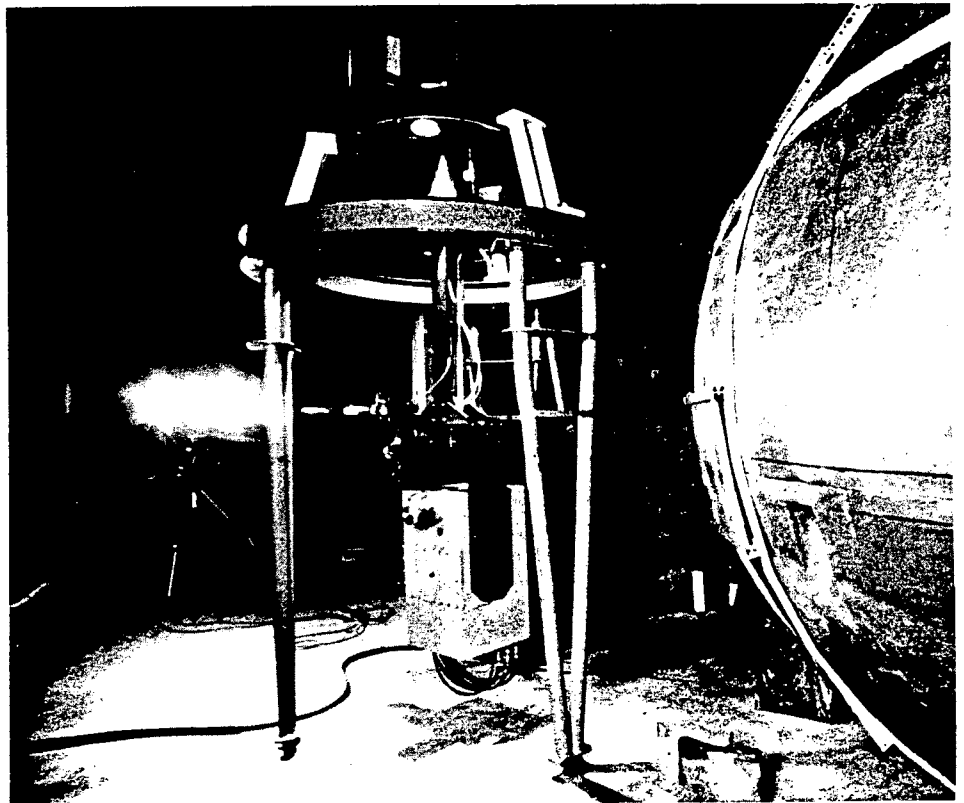

checks of three circumferential electrofusion welds that join four cast sections of a main reactor coolant pump at Rochester Gas and Electric's (RG&E's) Ginna Plant, on the south shore of Lake Ontario.

Manipulation equipment for holding and positioning Minac during the Ginna Plant inspections was designed and operated by RG&E personnel, who also provided the radiation expertise (the inspections were conducted inside the containment vessel of a nuclear generating unit).

The weld paths in the Ginna Plant pump varied in thickness from about 8.5 to 11.25 in. Because high radiation inside the pump would fog the film, the Minac radiation head was suspended within the pump cavity and the x-ray film was positioned outside the pump housing—the reverse of usual manufacturing inspection procedure. The control unit was outside the containment vessel, 200 ft from the inspection site.

Minac was operated continuously for 100 hr, during which time 100 exposures were made. Exposure times ranged from 20 min to 3.5 hr. Radiographs of excellent sensitivity (typically 1%) were achieved—in an application that was as difficult as any Minac is likely to have to perform.

In its second field use, Minac helped find the cause of a loss of power-generating capacity at Consolidated Edison's Indian Point Station, north of New York City. Flow tests indicated constriction in the primary steam lines—possibly in one or more of four main steam valves.

The steam valves have equivalent steel thicknesses of only 4–6 in. and so are not inherently difficult to radiograph. However, because the inspections must be made with the plant at full power, high temperatures and radiation posed problems.

Despite the difficult environment, Minac radiographs pinpointed the two valves that were partially closed. Calculations based on those constrictions showed close correspondence with the power loss. On the basis of Minac's findings, appropriate valve adjustments were made later, during a shutdown scheduled for other maintenance.

The Consolidated Edison program clearly demonstrated that Minac can be used effectively, in both fossil and

Cross-section of the main reactor coolant pump at RG&E's Ginna plant. Minac's radiation head was suspended within the pump cavity. The pump housing is about 10 ft in diameter and 10 ft high.

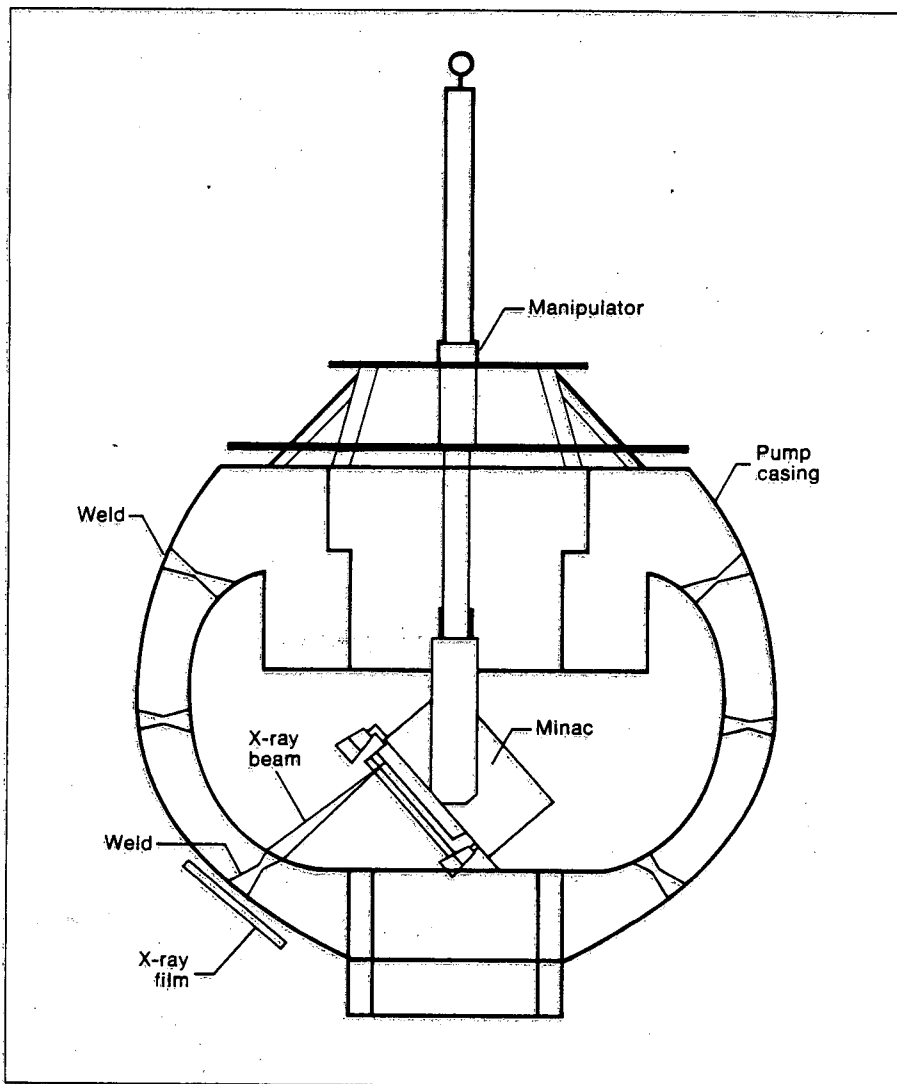

nuclear units, for a variety of valuable on-line diagnoses that cannot be accomplished by other means.

Two subsequent utilizations of Minac—reactor coolant pump inspections conducted at Point Beach, Wisconsin, and at Turkey Point, Florida—were equally successful.

A significant advance in the technology of nondestructive examination (NDE) of materials and components, Minac has proved the feasibility of doing thick-section radiography in the field with sensitivities equal to those attainable during component fabrication.

Minac is scheduled for further utility inspections through 1983, and a program is already under way to upgrade Minac's output to 6 MeV.

The experience gained during these first in-service uses of Minac, as well as the Minac equipment, will be made available to the utilities through EPRI's NDE Center, Charlotte, North Carolina. EPRI project manager is M. E. Lapedes, (415) 855-2063. Questions about the availability of Minac for commercial inspections should be directed to P. Schoenecke, EPRI NDE Center, (704) 597-6140.

ELECTRIC POWER RESEARCH INSTITUTE

Headquarters: Post Office Box 10412, Palo Alto, California 94303 (415) 855-2000

TBNP3-4/82

THERMAL ANALYSIS OF THE TMI-2 PRIMARY PRESSURE BOUNDARY AND
POTENTIAL IMPACT ON REQUALIFICATION PLANS:
S. W. Tagart, Jr. (Electric Power Research Institute),
K. E. Moore (B&W)

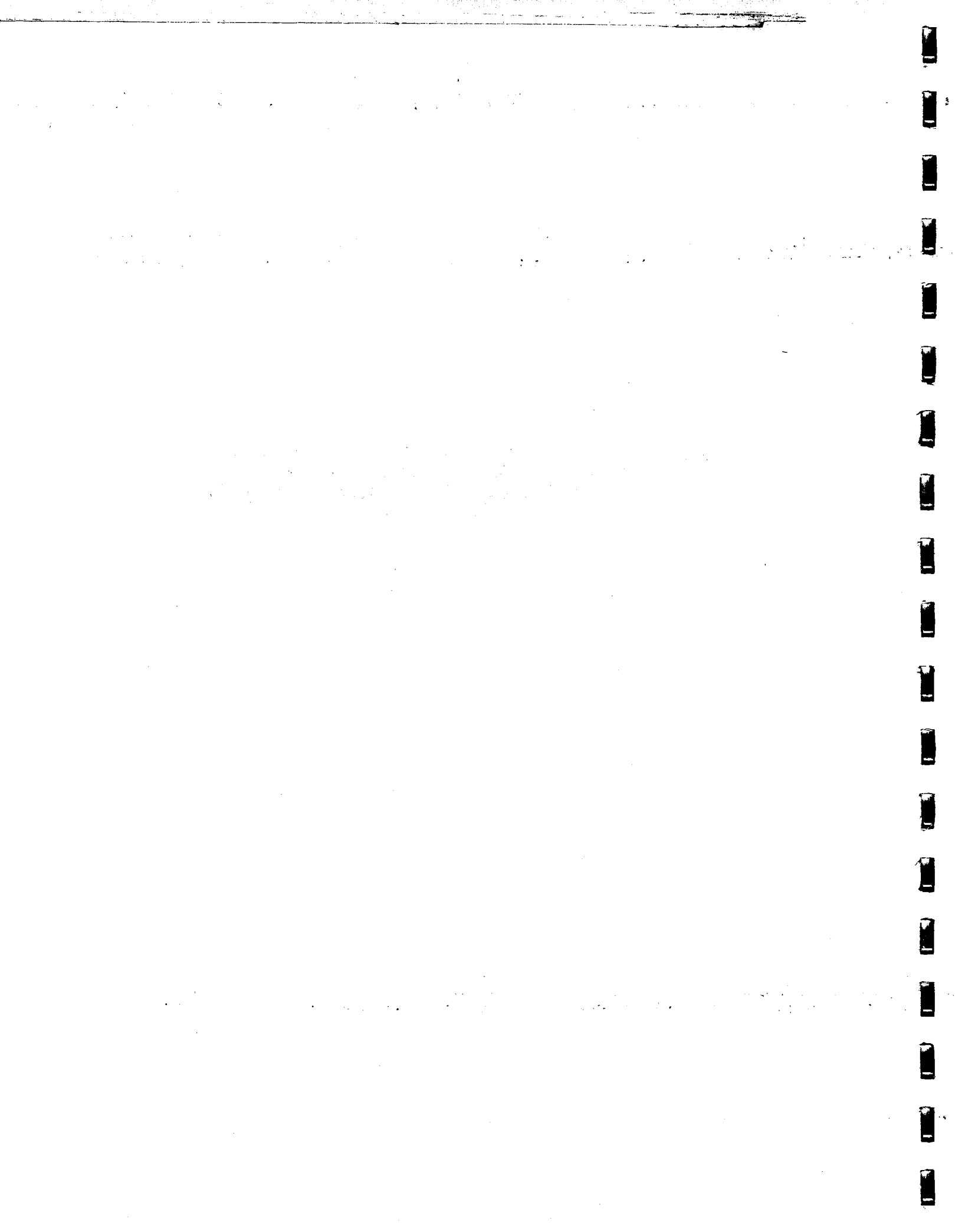

THERMAL ANALYSIS OF THE THREE MILE ISLAND
UNIT 2 PRIMARY PRESSURE BOUNDARY AND POTENTIAL IMPACT
ON REQUALIFICATION PLANS

The Electric Power Research Institute (EPRI) is sponsoring programs to determine what happened at Three Mile Island Unit 2 (TMI-2) and in particular what damage occurred to various pieces of equipment. Such information is valuable both in future safety assessments and in economic refurbishment efforts for plants which may experience various degrees of damage. In connection with pressure boundary damage assessment, EPRI has sponsored two research projects, RP1756 Component Requalification and RP2056 TMI-2 Primary Pressure Boundary Characterization. This summary report discusses the current status of these two projects.

The March 29, 1979, accident at TMI-2 involved a partially uncovered core with its attendant abnormal temperatures and abnormal heat transfer to the primary pressure boundary. In order to answer the questions of what exactly happened and what damage to equipment occurred, a series of engineering analyses has been performed by several parties, including the Nuclear Safety Analysis Center, General Public Utilities and the Electric Power Research Institute. Each of these analyses represents an attempt to piece together a coherent engineering description of the key process variables, such as coolant temperature and pressure,

coolant mass distribution, structural temperatures and loadings, all as a function of time during the accident. Since the accident was largely unanticipated, instrumentation which would unambiguously quantify the transient process variables was lacking. Therefore, the engineering analyses are necessarily an iterative process where boundary and initial conditions are selected and improved on the basis of available data plus judgment.

EPRI published a report, Cooper ⁽¹⁾, which advocates the generation of an engineering standard to be used in connection with retire/requalification decisions of worn or damaged pressure vessel type equipment. The chief benefits of a standard are 1) maximum utilization of previously generated qualification information and 2) mitigation of a crisis situation as a possible deterrent to the rational decision process, i.e., develop the requalification criteria before the crisis. This idea has received extensive industry review with favorable consensus, and the matter is currently under consideration by the ASME Board of Nuclear Codes and Standards.

The proposed requalification standard is an important aid to identify useful information from the damaged TMI-2 reactor. That is, by applying the requalification planning process to an actual situation, such as TMI-2, one can identify priorities for information retrieval. For example, the thermal transient temperature history of the TMI-2

reactor pressure vessel has been examined in an EPRI-sponsored scoping study, Brown, et al. (2). This study focused on four regions of the vessel: 1) the vessel beltline region, 2) the closure head region, 3) the outlet nozzle region, and 4) the inlet nozzle region. Significant thermal stresses were imposed during the TMI-2 transient and in the closure head region, gradients through the thickness are up to 350°F (177°C) and maximum temperatures may have reached 900°F (482°C) as shown in Figure 1. Therefore, some relaxation of the bolt pre-load may have occurred and verification of potential relaxation appears to be an important consideration for instrumentation during head removal. Such information will be valuable both in verifying what happened and in requalifying the vessel for future operation should that option be pursued.

In order to further integrate the generic requalification idea and the TMI-2 recovery effort, EPRI initiated in November 1981 contract work with Babcock & Wilcox (B&W) to carry out a number of tasks including the evaluation of the previously performed thermal scoping studies, and development of a requalification evaluation process and acceptance criteria for TMI-2 pressure boundary components. It is expected that this specific effort on the rather severe TMI-2 situation will provide important feedback on the proposed standards writing process and that, in turn, the standards effort will pose the important requalification questions which must be answered both generically and at TMI-2.

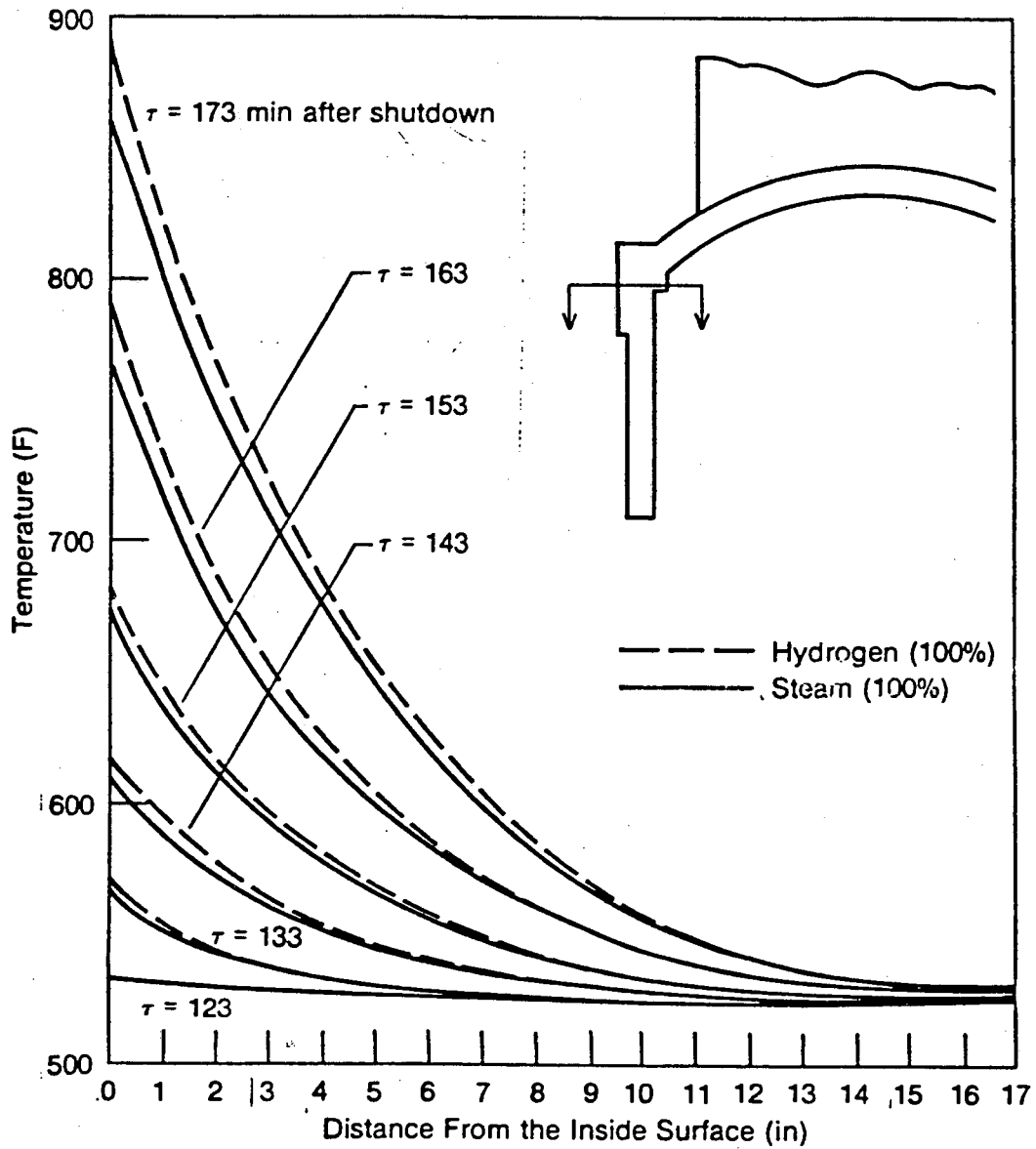

Figure 1 Top head region temperature distribution at various times.

References

1. W. E. Cooper, "Rationale for a Standard on the Requalification of Nuclear Class 1 Pressure-Boundary Components," EPRI Report NP-1921, October 1981.
2. D. L. Brown, D. F. Butzin, and C. A. Calkins, "Scoping Thermal Analysis of the Three Mile Island - Unit 2 Pressure Boundary," EPRI Project Number RP2056-1, draft report to be published in 1982.

[Faint, illegible text covering the majority of the page]



REQUALIFICATION

- COMPLETED PROJECTS
 - TECHNOLOGY GUIDE
 - STANDARDS DEVELOPMENT

REQUALIFICATION, CONT.

● EPRI CONCLUSION - PURSUE STANDARD PER NP 1921

- | | |
|--|----------|
| - INDUSTRY REVIEW AND CONSENSUS | JAN 1982 |
| - ANALYSIS OF INDUSTRY COMMENTS | MAY 1982 |
| - AGENDA OF ASME BOARD ON NUCLEAR
CODES AND STANDARDS | AUG 1982 |
| - MAIN B&PV CODE SET-UP COMMITTEE | -- |
| - DEVELOP ALLOWABLE TIME AT ELEVATED
TEMPERATURE | -- |
| - CRITERIA FOR ENERGY LIMITED EVENTS | -- |

8 SCREENING CRITERIA

1. MAXIMUM TEMPERATURE LESS THAN APPENDIX 1 OF ASME B&PV CODE SECTION III
2. TECHNICAL SPECIFICATION CORROSION LIMITS
3. EXCESSIVE RADIATION EXPOSURE
4. TECHNICAL SPECIFICATION PRESSURE-TEMPERATURE LIMITS
5. PRESSURE EXCURSION \leq 110% OF DESIGN PRESSURE
6. SEISMIC EVENT \leq 50% OF SAFE SHUTDOWN EARTHQUAKE
7. VIOLATION OF PIPING GEOMETRIC CONFIGURATION
8. ALL LOADINGS \leq B SERVICE LEVELS FOR PRIMARY STRESS OR DIMENSIONAL MEASUREMENTS PLUS ISI

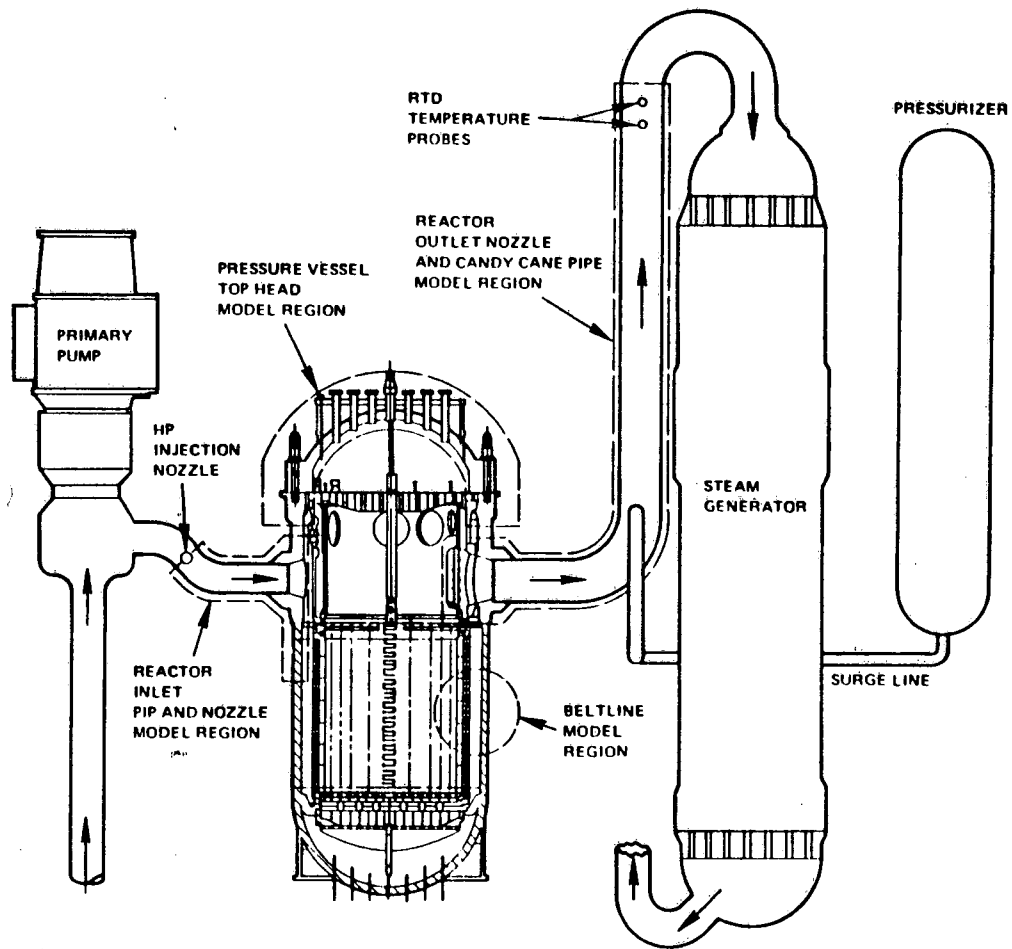

TMI-2 Primary System Schematic

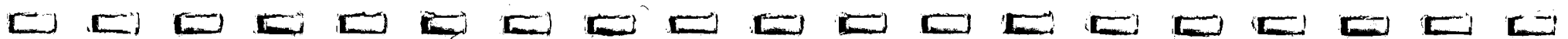

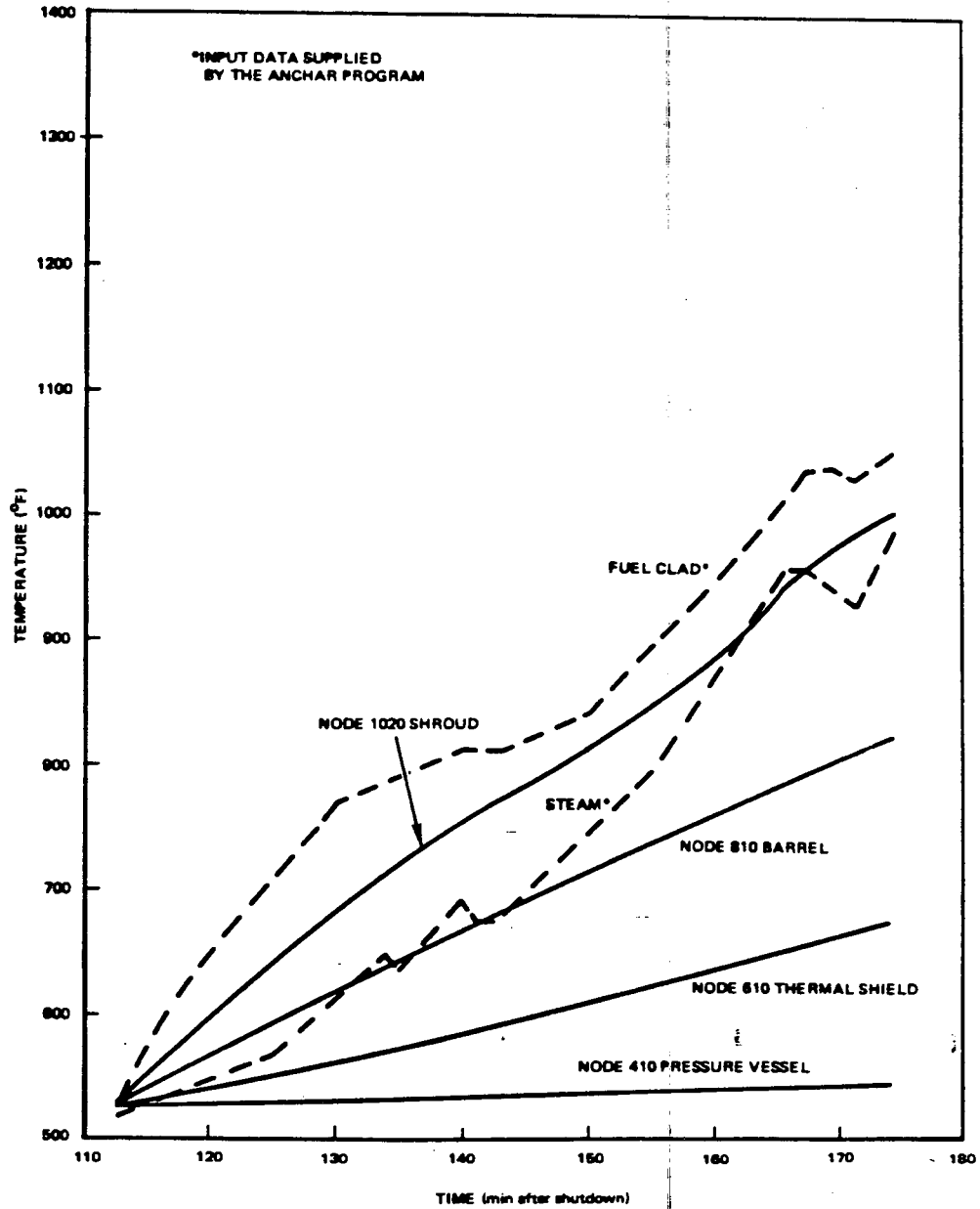

Beltline Temperature History 4.5% (Nominal) Gamma Leakage Case

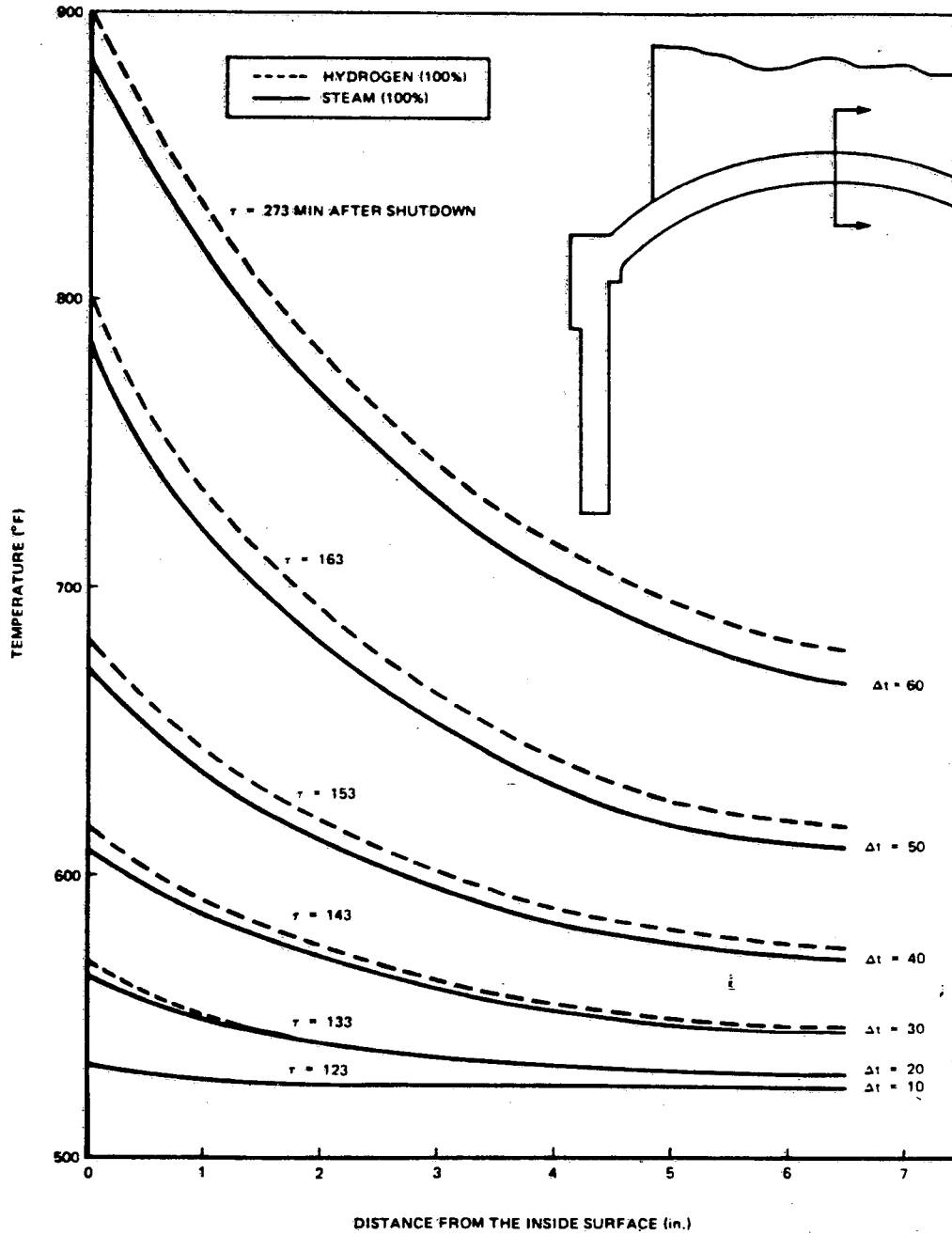

Top Head Centerline Region-Temperature Distribution
 at Various Times

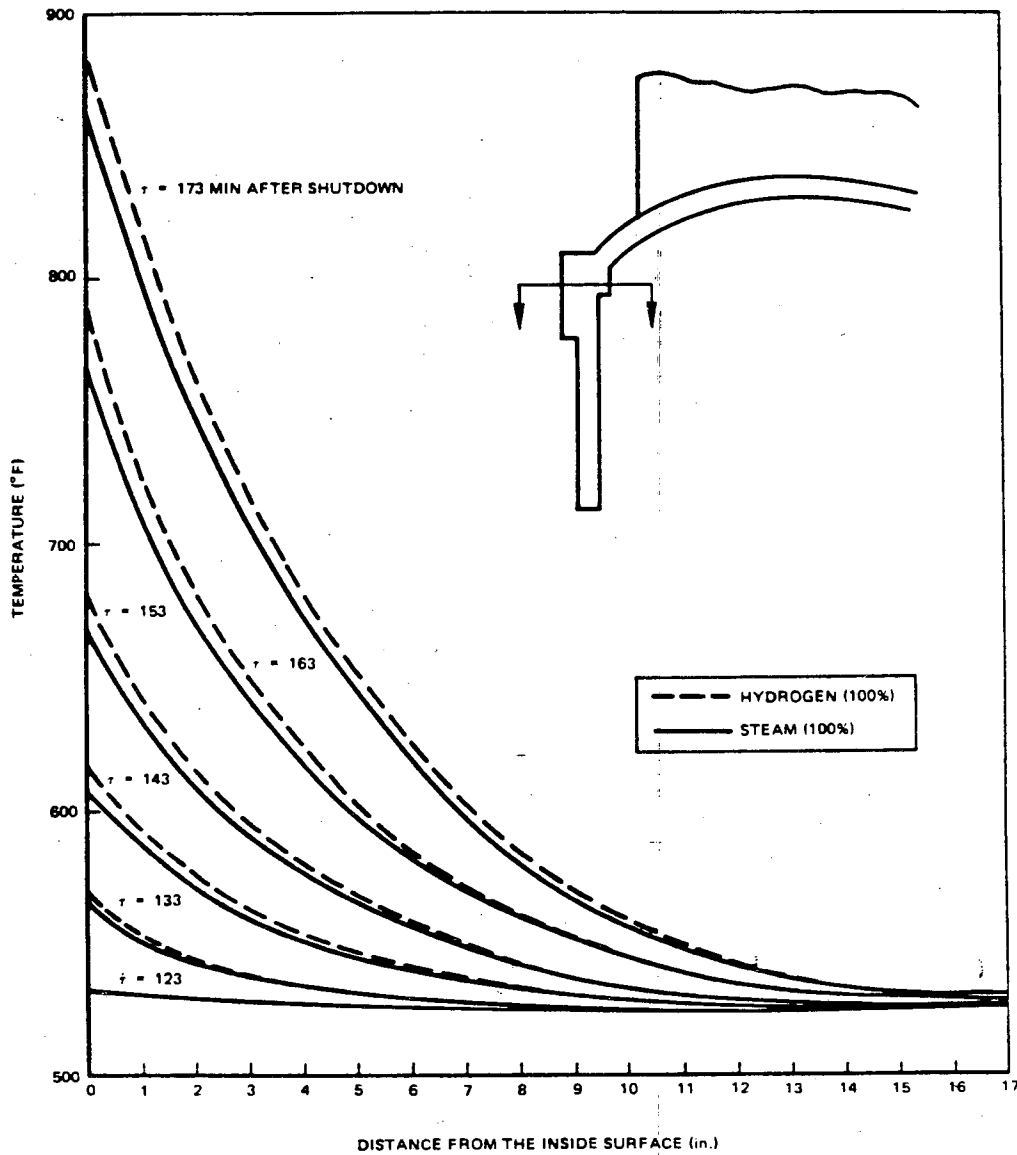

Top Head Flange Region-Temperature Distribution
at Various Times

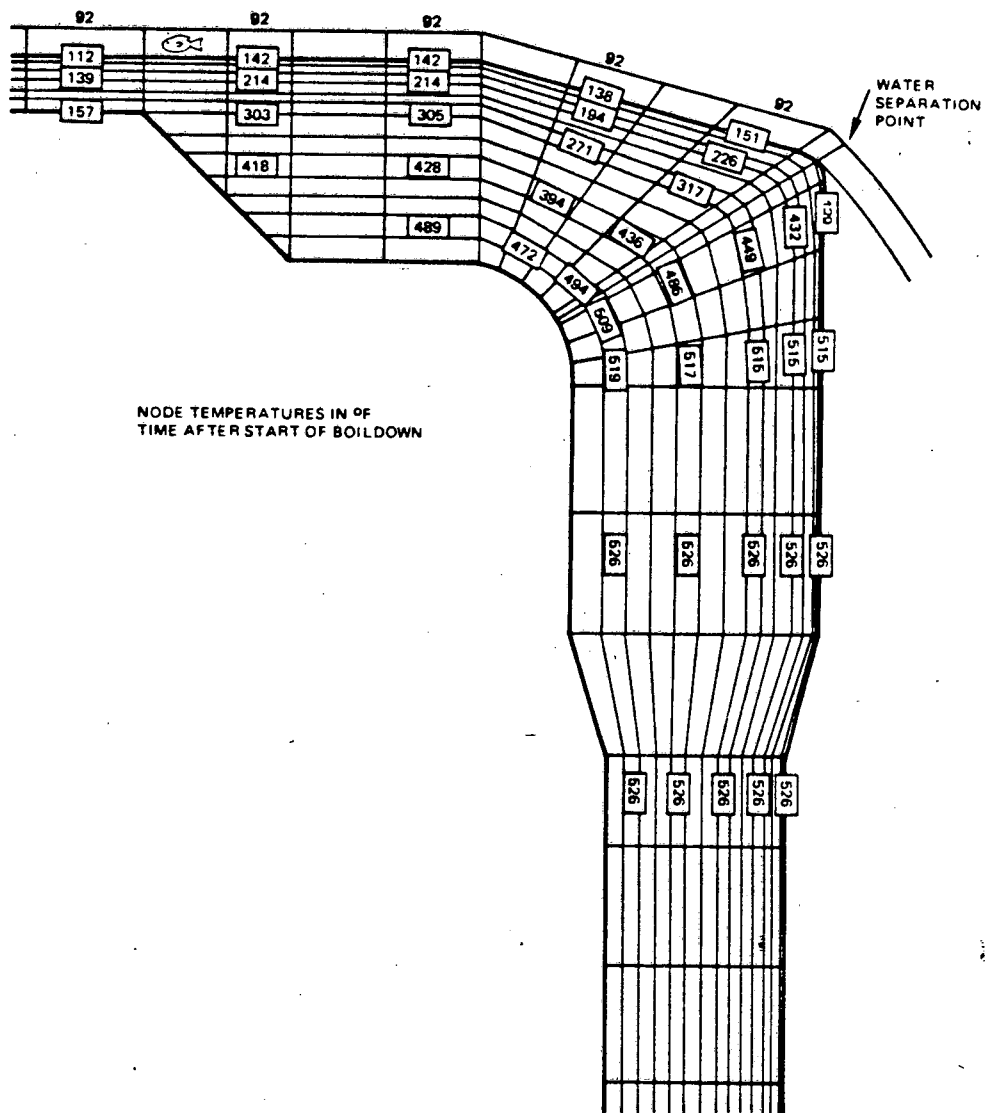

Nozzle Region Selected Nodal Temperatures
at 10 min Separated Flow

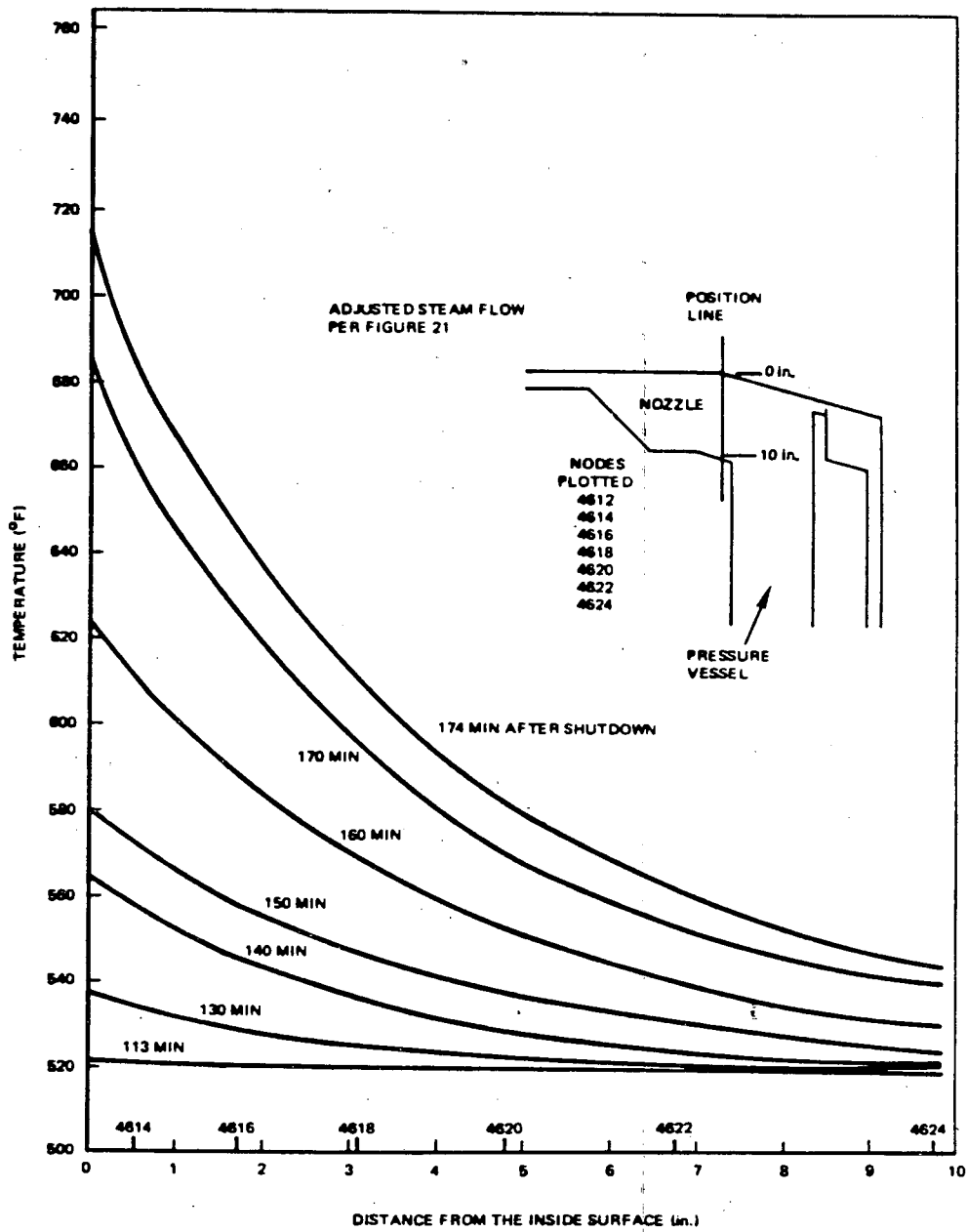

Outlet Nozzle Temperature Profiles Adjusted Steam Flow Rate

REQUALIFICATION, CONT.

- EPRI TMI-2 APPLICATION, RP2056-2
 - RPV HEAD CLOSURE ASSEMBLY
 - REMAINING PRESSURE BOUNDARY COMPONENTS
 - INTEGRATION OF TMI-2 EXPERIENCE WITH STANDARDS WORK

INVESTIGATION OF HYDROGEN BURN DAMAGE IN THE
TMI-2 REACTOR BUILDING:
N. J. Alvares, D. G. Beason
(Lawrence Livermore National Laboratory),
G. R. Eidam, D. L. Reeder (EG&G Idaho, Inc.)

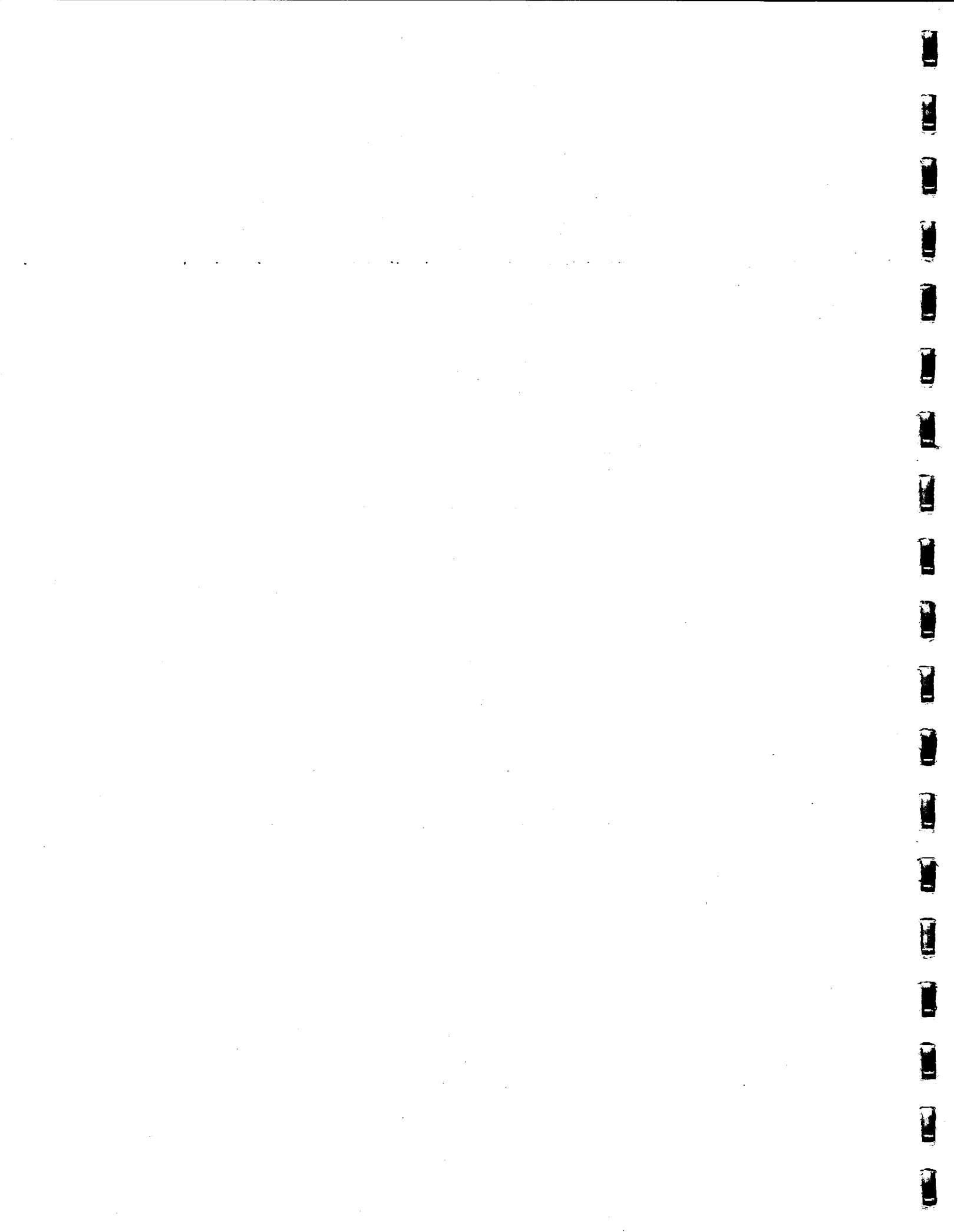

INVESTIGATION OF HYDROGEN BURN DAMAGE
IN THE TMI-2 REACTOR BUILDING*

N. J. Alvares, Lawrence Livermore National Laboratory

D. G. Beason, Lawrence Livermore National Laboratory

G. R. Eidam, EG&G Idaho, Inc.

D. L. Reeder, EG&G Idaho, Inc.

Fifteen entries into the TMI-2 reactor building were made in the period between the accident on March 28, 1979 and October 1981. Photographs and video recordings from these entries were made in association with radiation and decontamination surveys. These studies did not allow for ordering of visual data to best display patterns of thermal damage. Such patterns, if any, may reveal spatially distributed thermal exposure information and thermal exposure intensity, ascertained from the degree of damage to the exposed item.

The Fire Science Group of the Hazards Control Department at Lawrence Livermore National Laboratory (LLNL) and EG&G Idaho, Inc. in cooperation with the Nuclear Regulatory Commission (NRC) and the Department of Energy (DOE) conducted a preliminary analysis of existing photographs of thermally damaged materials in the TMI-2 reactor building. From this survey, we attempted to define spatial distribution and extent of thermal damage to susceptible reactor building items. We also recommended further work that could increase the accuracy of estimates of hydrogen deflagration intensity for the purpose of estimating hydrogen concentration range in the reactor building just prior to the deflagration.¹ In our research we examined photographic evidence from the first fifteen reactor building entries and then suggested a preliminary pattern of burn and overpressure damage throughout the TMI-2 reactor building.

* Work supported by the U.S. Department of Energy, Assistant Secretary for Nuclear Energy, Office of Coordination and Special Projects, under DOE Contract No. DE-AC07-76ID01570.

Approach

Our approach was to segregate and organize existing photographs into categories where the pictures showed: (1) items that definitely exhibit effects of thermal exposure (charred, sooted, melted, thermally relaxed, blistered, discolored, and embrittled items); (2) items susceptible to--but not exhibiting--thermal damage; (3) items not susceptible to thermal damage at temperature levels found in fires and explosions (we deleted these photographs from our analysis); and (4) items that exhibit "blast" or overpressure damage.

Preliminary photographs received at LLNL from the NRC contained only a portion of those available at TMI. To expedite progress, two members of the Fire Science Group staff traveled to the Department of Energy (DOE) Technical Integration Office (TIO) on TMI to survey their file of photographs and schematics, and to construct preliminary thermal damage distribution maps. As we sorted and organized photographs, we plotted positions of thermal damage on plan view schematics of the reactor building levels.

Upon returning to LLNL, we constructed an approximate scale model of the reactor building interior using polystyrene foam. Thermal and blast damage locations were transcribed from schematics to the model to better illustrate spatial location of damage. The model was transported to DOE Headquarters to help illustrate the thermal damage spectrum for a meeting pertaining to analysis of the TMI-2 hydrogen reaction. After the meeting the model was taken to TMI-2 so that damage data from subsequent reactor building entries could be added to existing patterns.

Interim Results

Very tentative patterns can be suggested with the limited information available to this analysis. While much more information is required before credence can be given to interpretations of both thermal and overpressure damage, we do offer the following preliminary estimates based on our data.

1. Blast or overpressure damage appears to be localized in regions around the elevator and enclosed stairwell complex. More indications of blast damage may exist in basement regions which, because of radiological hazards, have not yet been surveyed.
2. Thermal damage to polar crane components appears uniform. Discharge of the air coolers through the LOCA ducts may have been a primary dispersal mechanism of hydrogen and air to the polar crane region. No evidence of overpressure damage was found on polar crane components.
3. Thermal damage on the 347-foot elevation exists in the reactor building's north, east, and south quadrants, while none is found in the west quadrant behind the D-ring. These patterns may follow flow paths developed by discharge of the air coolers through the LOCA ducts.
4. Photographs of the 305-foot elevation indicate minimal thermal damage in that area. Thermal damage to a telephone cord and elevator control buttons could have resulted from either hot gas emission from the distorted elevator and stairwell doors nearby, or from hydrogen fire flow.

Much more information will be required before the full extent and range of the hydrogen burn during the accident is understood. Further close examination of various thermally-damaged items located in southern areas of the 347-foot elevation might allow a better estimate of exposure intensity than is now available.

Studying such fine fuels as thin films, paper, cloth, and thin insulated wire which respond to constant energy exposure in predictable ways relative to their composition and geometry could yield more precise data on the burn. Another strategy to further define exposure conditions is to attempt to duplicate the thermal damage in a laboratory with a reasonable set of experimental sources. As more information of this nature is gathered,

investigators can compile a more complete set of facts with which to understand the full nature and extent of hydrogen burn damage at TMI-2.

Reference

1. N. J. Alvares et al., Investigation of Hydrogen Burn Damage in the Three Mile Island Unit 2 Reactor Building, GEND-INF-023, Volume I, June 1982.

ANALYSIS OF THE TMI-2 HYDROGEN BURN:
J. O. Henrie (Richland Hanford Operations),
A. K. Postma (Benton City Technology)

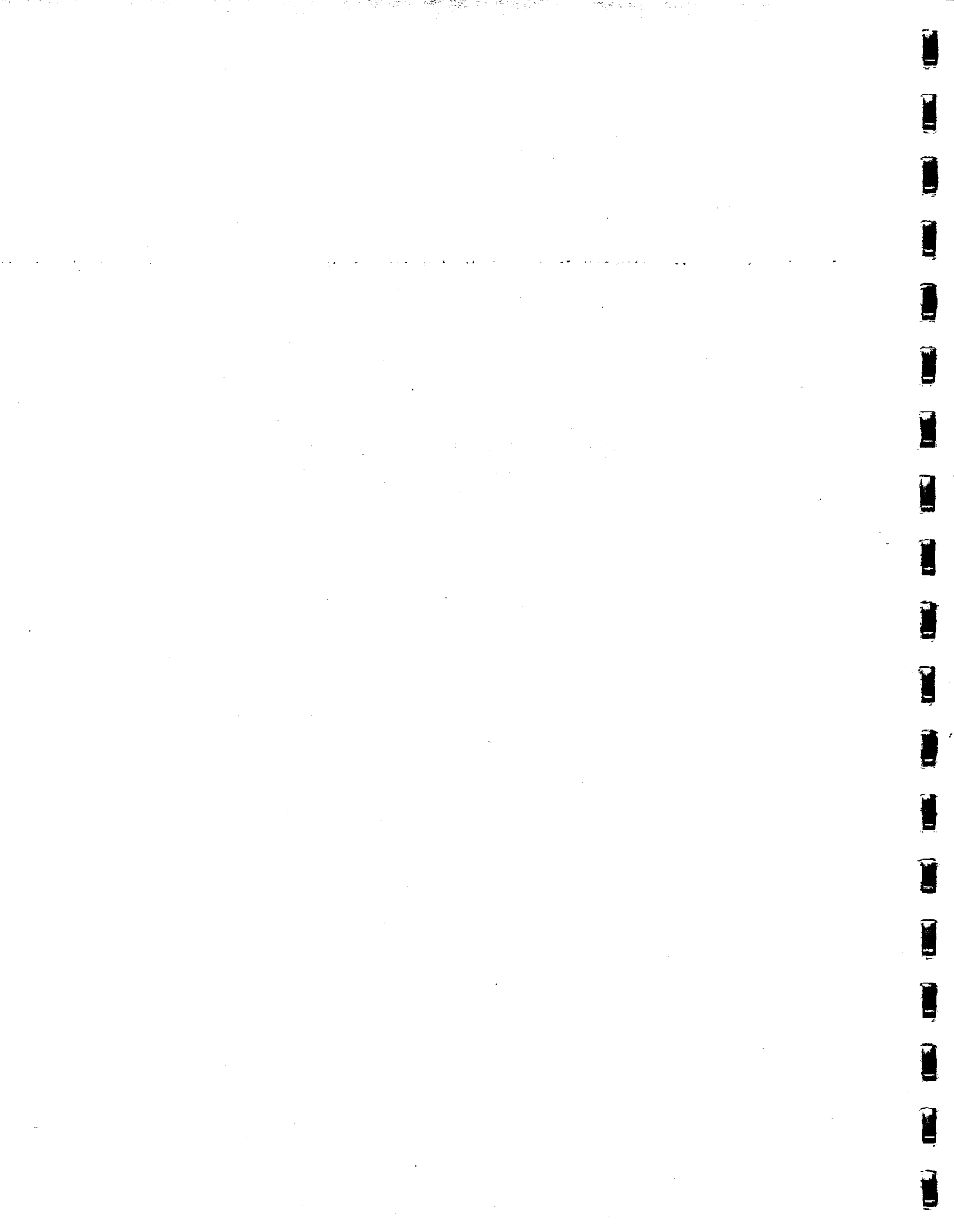

ANALYSIS OF THE THREE MILE ISLAND (TMI-2)
HYDROGEN BURN

J. O. Henrie
A. K. Postma

Program Engineering

July 1982

Prepared for the United States
Department of Energy Under
Contract DE-AC06-77RL01030

Rockwell International
Rockwell Hanford Operations
Energy Systems Group
Richland, Washington 99352

ABSTRACT

As a basis for the analysis of the hydrogen burn which occurred in the Three Mile Island Containment on March 28, 1979, a study of recorded temperatures and pressures was made. Long-term temperature information was obtained from the multipoint temperature recorder which shows 12 containment atmosphere temperatures plotted every 6 min. The containment atmosphere pressure recorder provided excellent long- and short-term pressure information. Short-term information was obtained from the multiplex record of 24 channels of data, recorded every 3 sec, and the alarm printer record which shows status change events and prints out temperatures, pressures, and the time of the events. The timing of these four data recording systems was correlated and pertinent data were tabulated, analyzed, and plotted to show average containment temperature and pressure versus time. Photographs and videotapes of the containment entries provided qualitative burn information.

Hydrogen concentrations were calculated using the following information:

- a. Analysis of the burn peak projected back to a theoretical zero-time burn
- b. Gas addition from containment temperature and pressure measurements before the hydrogen burn
- c. Gas depletion from containment temperature and pressure measurements before and after the hydrogen burn
- d. Rate of pressure rise during the burn
- e. Oxygen depletion from chemical analyses.

Postburn average ambient temperatures versus time were calculated from recorded pressure data, and from empirical data obtained from shock tube tests conducted by Rockwell in 1973.⁽¹⁾ Average temperatures were calculated for the region above elevation 347, below elevation 347, and within the D-ring compartments.

The analyses indicate the following:

1. Prior to the burn, the hydrogen was well mixed with the containment air. The average hydrogen concentration was calculated to be 7.9%, wet basis.
2. The hydrogen burn occurred at all three levels in the containment. The burn was initiated somewhere in the lowest level; probably on the west side. Even though the burn time was about 12 sec, nearly all of the burning occurred during a 6-sec period. Over half of the burning occurred during the last 3-sec period.
3. About 3,570 standard (0°C) cubic meters (126,000 standard cubic feet), 160 kg (351 lb) moles or 319 kg of hydrogen burned. Approximately 1.1% hydrogen remained after the burn and 0.6% was released from the reactor cooling system to containment during the first hour after the burn.

4. Containment gas temperatures in the flame front were about 760°C (1400°F). The average containment gas temperature at the end of the burn was about 660°C (1220°F).
5. The gas temperatures decreased much faster below elevation 347 (large ratio of exposed surface area to containment gas volume) than above elevation 347 (low ratio of exposed surface area to containment gas volume). Curves are presented which show the calculated average gas temperatures versus time in these two containment zones and in the D-rings.
6. The average temperature rise of all materials and components in the reactor building, including the containment shell, was calculated to be only about 1.2°C (2.2°F) as a result of the hydrogen burn. Considerably more energy came from the hot water and steam vented from the cooling system to the containment than from the hydrogen burn. This resulted in the massive shield temperatures increasing an average of about 40°C (80°F) in 2 days. In the long-term, most of the heat was removed by the air coolers.

The burn damage observed was predominantly at the upper elevations and on the east and south quadrants. The vertical distribution resulted not only from the lower ratio of exposed surface area to gas volume at the upper elevations, but also from a more complete burning at the higher elevations. Therefore, significant damage to hydrocarbon materials would be expected at high elevations and not at low elevations.

The reason for lack of burn damage on the west side is probably due to the steam vent from the coolant drain tank terminating on that side. Temperature data show the west side temperatures heating rapidly while steam was venting, then actually subcooling (from evaporation of wet surfaces) after steam venting was terminated. Similar heating and cooling did not occur on the east side. Therefore, walls, floors, and equipment on the west side were very wet and evaporation kept their temperatures near or below the boiling point of water throughout much of the postburn cooling period.

On the north side the D-rings are relatively close to the containment wall, resulting in a large ratio of exposed surface area to containment gas volume. This condition causes rapid cooling which minimizes burn damage.

Approximately 1.1% hydrogen remained in the containment after the burn. Venting of the reactor cooling system during the hour following the burn added an additional 0.6%. Hydrogen concentrations increased from this 1.7% to about 2.2% between March 30 and April 2 as the reactor cooling system (RCS) was vented. One of two Rockwell hydrogen recombiners was operated for 1 month and removed 112 kg of hydrogen. When recombiner operation was terminated, the containment hydrogen concentration was 0.7%. This hydrogen was vented to the atmosphere in July 1980.

A total of 459 kg of hydrogen gas were accounted for. Assuming somewhat arbitrarily that 90% of the hydrogen was generated by the zirconium-steam reaction and 10% by radiolysis, 9,300 kg (20,500 lb) of zirconium would have been oxidized.

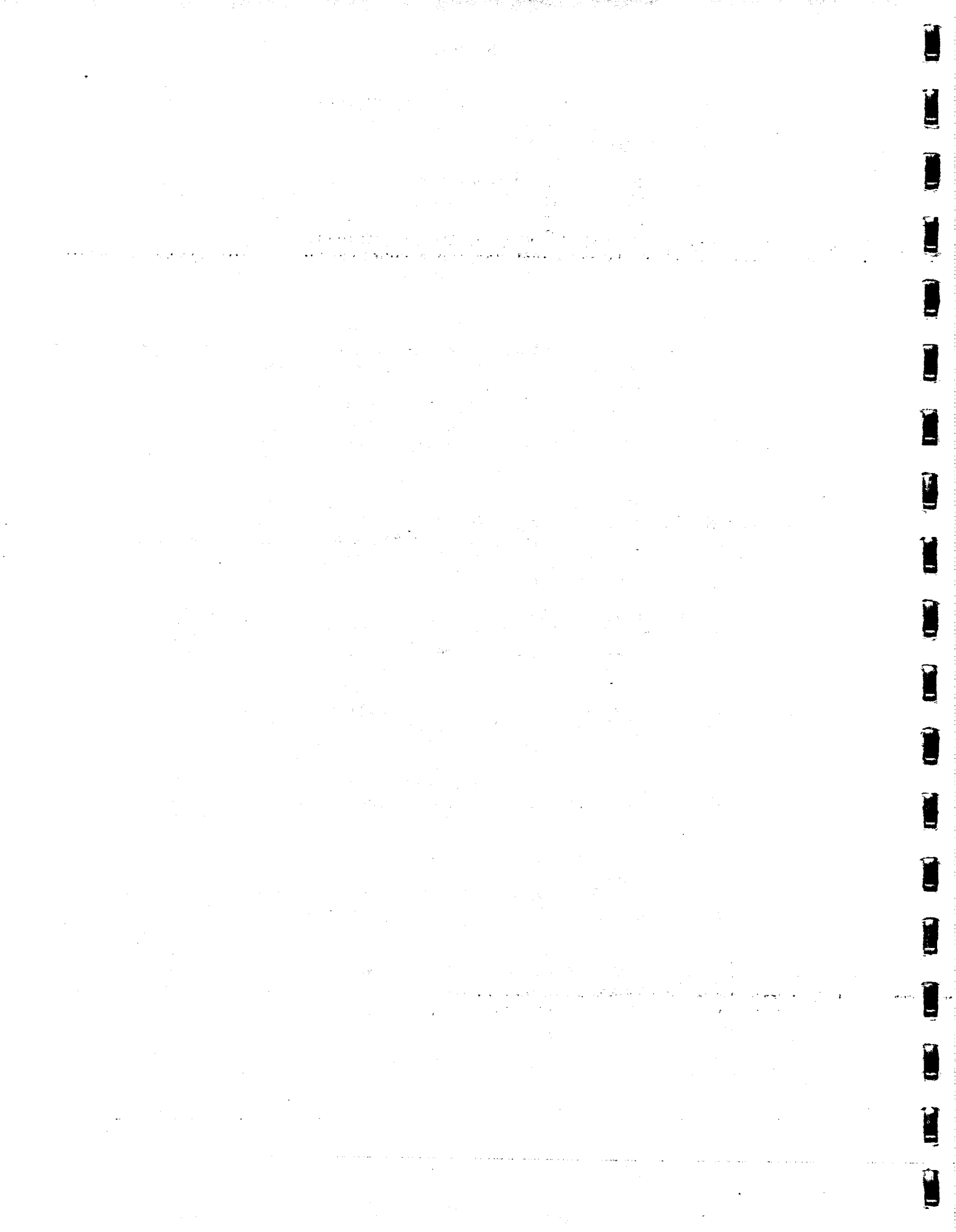

TMI-2 HYDROGEN BURN

J. O. HENRIE

A. K. POSTMA

- OBJECTIVES
- SOURCES OF DATA AND USEFULNESS
- PREBURN CONDITIONS
- HYDROGEN BURN
- POST-BURN TEMPERATURE DISTRIBUTIONS
- BURN DAMAGE
- QUANTITY OF HYDROGEN & PROJECTED CORE DAMAGE

OBJECTIVES

- DETERMINE QUANTITY OF HYDROGEN REMOVED FROM CONTAINMENT BY BURNING, CONTROLLED RECOMBINATION AND VENTING.
- DETERMINE THE BURN CHARACTERISTICS TO ESTABLISH A BASIS FOR SAFETY REGULATIONS AND DESIGN OF EQUIPMENT WHICH CAN SURVIVE SIMILAR BURNS.
- DETERMINE QUANTITY OF HYDROGEN PRODUCED TO PROJECT PROBABLE CORE DAMAGE AND AID IN RECOVERY PLANNING.

SOURCES OF DATA AND USEFULNESS

1. MULTIPOINT TEMPERATURE RECORDER
 - 24 POINTS EVERY 6 MINUTES
 - CHART SPEED 4.5"/HR.
 - LONG-TERM TEMPERATURE TRENDS
 - TEMPERATURE BASIS FOR GAS DEPLETION
 - EVIDENCE OF GOOD GAS MIXING
 - EVIDENCE OF BURN AT ALL LEVELS
2. PRESSURE RECORDER
 - CONTINUOUS - 2 RANGES
 - CHART SPEED 1"/HR.
 - PRESSURE PULSE FROM BURN
 - LONG-TERM PRESSURE TRENDS
 - PRESSURE BASIS FOR GAS DEPLETION
 - PEAK PRESSURE FOR H₂ BURN QUANTITY AND TEMPERATURE CALCULATIONS
3. GAS ANALYSES
 - H₂ QUANTITIES AFTER BURN
 - BASIS FOR O₂ DEPLETION ANALYSIS

SOURCES OF DATA AND USEFULNESS

4. PLANT COMPUTER
 - EVENTS TIMED TO THE SECOND
 - BEST PRESSURE RISE DATA
 - GOOD PRESSURE FALL DATA
 - HELPS ESTABLISH PROBABLE BURN PATH
 - RATE OF RISE AND PEAK PRESSURE BASIS FOR H₂ BURN QUANTITY
5. REACTIMETER (MUX) MONITOR
 - 24 POINTS, SCANNED EACH 0.1 SECONDS,
 - PRINTED EACH 3 SECONDS
 - GOOD SHORT-TERM PRESSURE INFORMATION
 - HELPS ESTABLISH PROBABLE BURN PATH
 - RATE OF RISE AND PEAK PRESSURE BASIS FOR H₂ BURN QUANTITY
 - SHOWS WHEN WATER SPRAY CONTACTED CONTAINMENT GAS
 - SHOWS PROBABLE AFTERBURN

PREBURN CONDITIONS

- ALL FIVE BLOWERS OPERATING - 235,000 ACFM
- HYDROGEN IN CONTAINMENT 1 TO 6 HOURS - WELL MIXED
- GAS PRESSURE - 16 PSIA
- AVERAGE GAS TEMPERATURE ~ 1280 F
- ESTIMATED WATER VAPOR CONCENTRATION - 3.5 VOL.%.
- PRESSURE RELIEF VALVE OPEN FOR 1/2 TO 1 MINUTE.

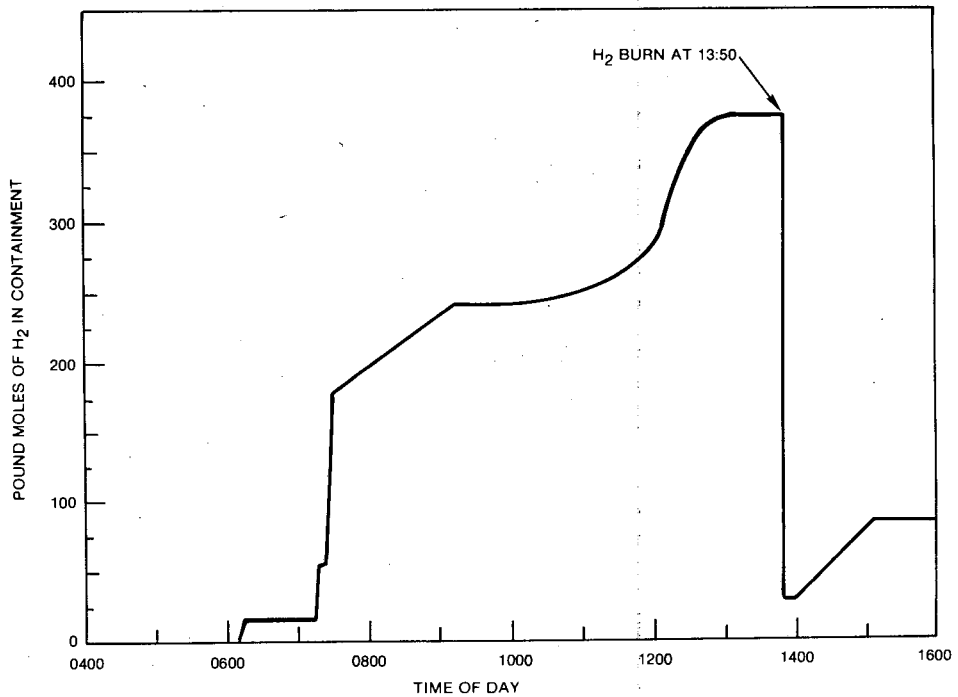

PROJECTION OF HYDROGEN ACCUMULATION IN CONTAINMENT

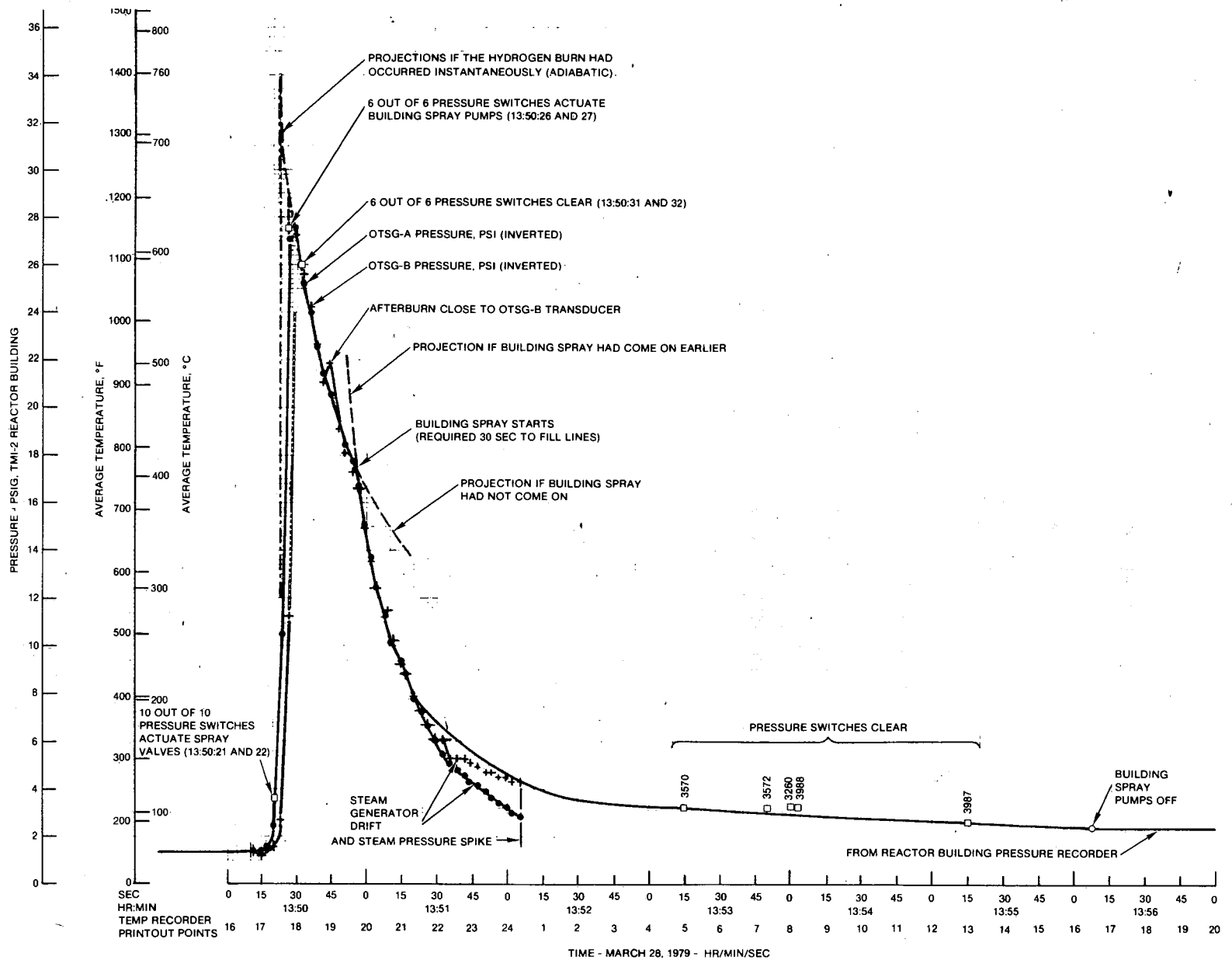

COMPOSITE TMI-2 CONTAINMENT AVERAGE TEMPERATURE AND PRESSURE VERSUS TIME

QUANTITY OF HYDROGEN BURNED

- THEORETICAL ADIABATIC BURN PROJECTION
- GAS ADDITION
- GAS DEPLETION
- PRESSURE RISE RATE - BURN VELOCITY
- OXYGEN DEPLETION.

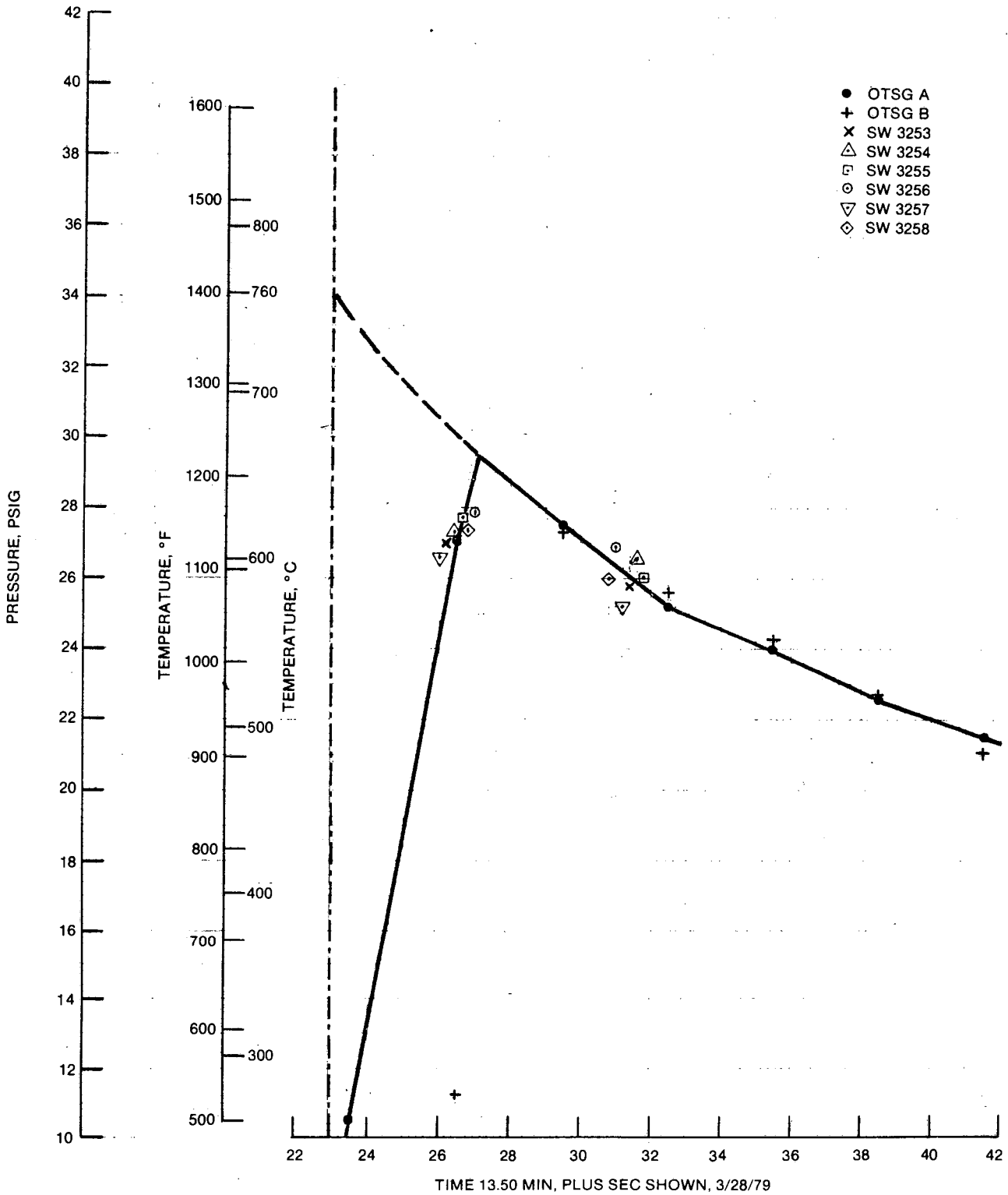

PEAK CONTAINMENT PRESSURE/AVERAGE TEMPERATURE
 PROJECTED BACK TO A THEORETICAL "ZERO-TIME" BURN

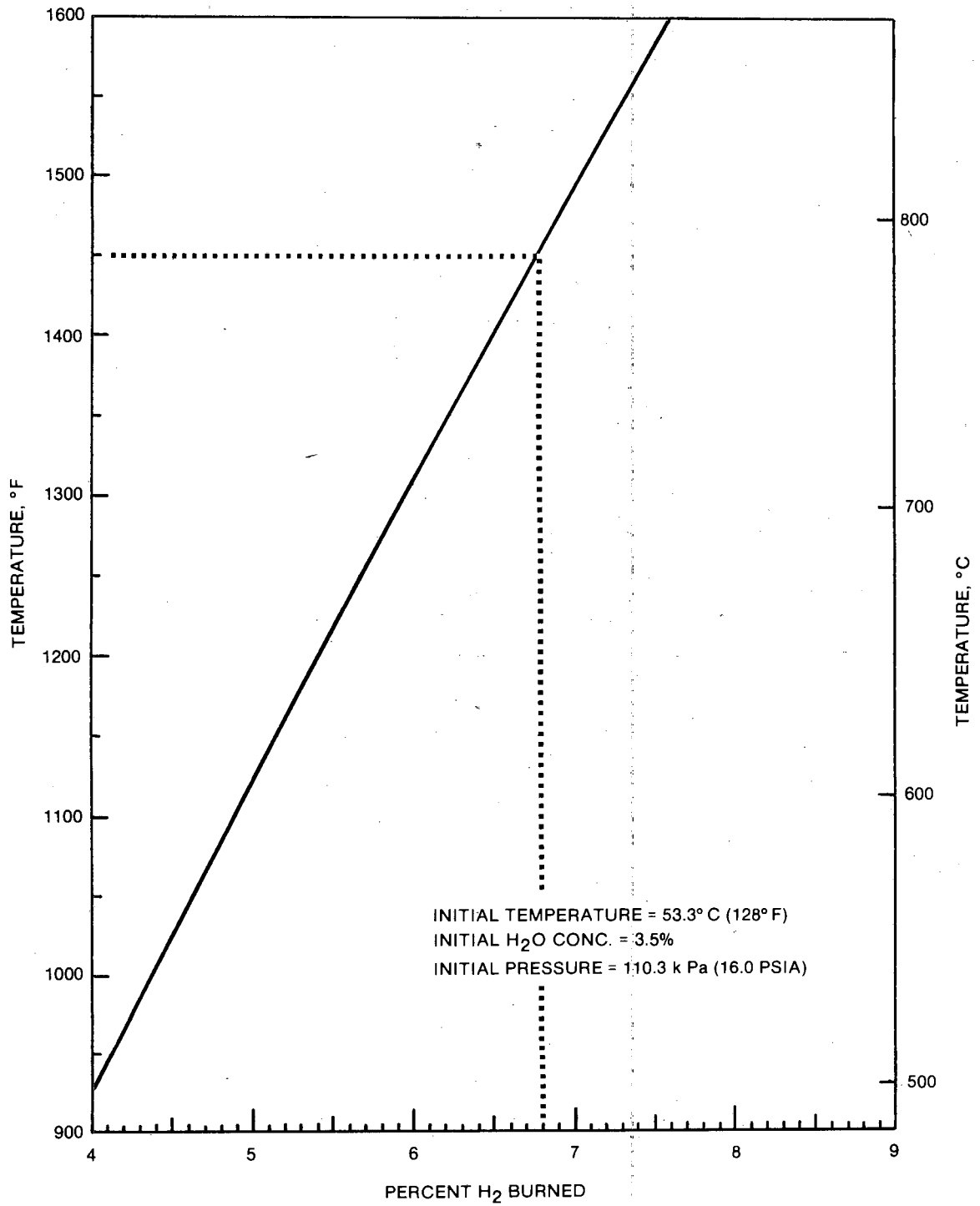

PREDICTED CONTAINMENT TEMPERATURE FOR
AN ADIABATIC ISOCHORIC HYDROGEN BURN

GAS ADDITION

- QUANTITY OF GAS IN CONTAINMENT JUST PRIOR TO H₂ BURN MINUS THAT PRIOR TO LOSS OF COOLANT
- CALCULATIONS BASED ON TEMPERATURE, PRESSURE, AND GAS LAW
- REQUIRES CORRECTION FOR WATER VAPOR CHANGES
- % WATER VAPOR IN CONTAINMENT GAS IS SAME AS FOR SATURATED GAS EXITING AIR COOLER 85 MINUTES AFTER PRESSURE RELIEF VALVE CLOSES (SEE NEXT SLIDE)
- GAS IN CONTAINMENT PRIOR TO BURN 4.970 # MOLES
- GAS IN CONTAINMENT PRIOR TO LOCA 4.560 # MOLES
- GAS ADDED PRIOR TO BURN = 410 # MOLES
= 7.9% WET BASIS, 8.2% DRY BASIS.

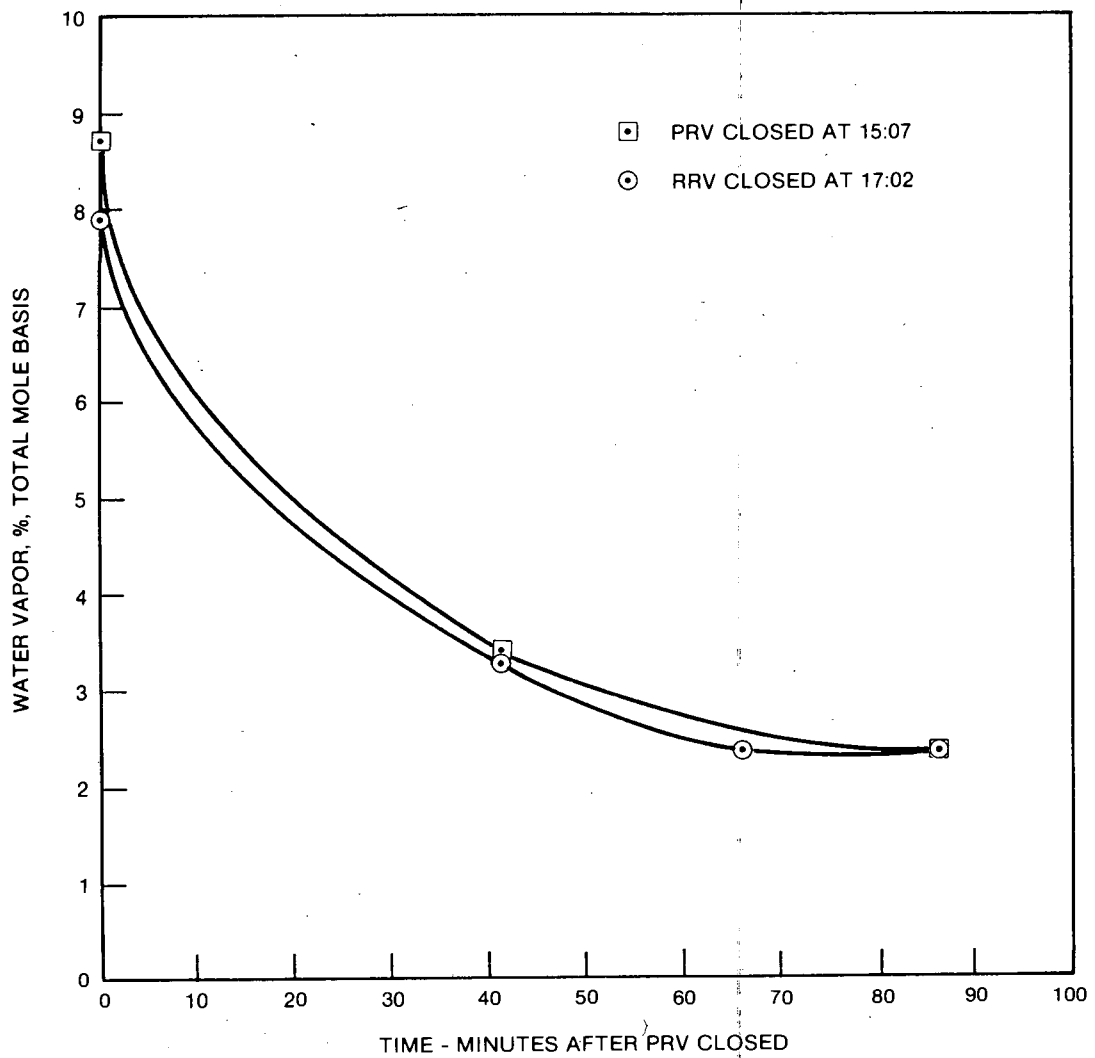

PERCENTAGE WATER VAPOR AS A FUNCTION OF TIME AFTER PRV CLOSURES

GAS DEPLETION

- QUANTITY OF GAS IN CONTAINMENT JUST PRIOR TO H₂ BURN MINUS THAT JUST AFTER H₂ BURN
- GAS AND WATER VAPOR CALCULATIONS SAME AS FOR GAS ADDITION
- GAS IN CONTAINMENT PRIOR TO BURN 4,970 # MOLES
- GAS IN CONTAINMENT AFTER BURN 4,530 # MOLES
- GAS CONSUMED DURING BURN 440 # MOLES
- HYDROGEN CONSUMED DURING BURN (x 2/3) 293 # MOLES
- HYDROGEN REMAINING AFTER BURN (1.1% DRY BASIS) 50 # MOLES
- TOTAL CALCULATED PREBURN HYDROGEN 343 # MOLES
- 6.9% - DRY BASIS, APPEARS TO BE 1.3% LOW.

PRESSURE RISE RATE - BURN VELOCITY

- QUALITATIVE METHOD.
- FOR 7.9% H₂, WET BASIS, BURNING IS PREDOMINANTLY UPWARD AND VELOCITIES ARE TYPICALLY LESS THAN 5 FT PER SECOND, DEPENDING ON TURBULENCE.
- PRV OPEN FOR 1/2 TO 1 MINUTE PROVIDED A H₂ RICH PLUME MOVING PREDOMINANTLY UP THE WEST SIDE, OPEN STAIRWAY.
- TIMED PRESSURE DATA FROM REACTIMETER AND PLANT COMPUTER INDICATE THAT BURNING STARTED BELOW ELEVATION 305, WEST SIDE, AND ENDED BELOW ELEVATION 305, EAST SIDE. COMPARTMENTS AND HORIZONTAL DIRECTION DELAYED BURNING BELOW ELEVATION 305.
- TURBULENCE FROM TALL CHIMNEY EFFECTS, COMPRESSION CURRENTS, AND 5 BLOWERS OPERATING, AND GAS PREHEATING FROM COMPRESSION AND RADIATION, COULD RESULT IN THE APPARENT 30 FT PER SEC FLAME SPEEDS DURING THE LAST FEW SECONDS.

OXYGEN DEPLETION

- THE HYDROGEN CONCENTRATION IN A HYDROGEN-AIR MIXTURE CAN BE CALCULATED FROM MEASURED POSTBURN HYDROGEN AND OXYGEN CONCENTRATIONS.
- POSTBURN OXYGEN ANALYSIS DATA FROM 3/31/79, 4/1/79 AND CORRECTED BACK TO 3/28/79 FOR HYDROGEN ADDED DURING THAT PERIOD, RESULTS IN AVERAGES OF 16.2% O₂ AND 19.0% O₂, RESPECTIVELY. DIFFERENT SAMPLING TECHNIQUES AND AIR IN-LEAKAGE MAY HAVE CAUSED THE DISCREPANCIES.
- BURNING OF A MIXTURE OF 8.2% H₂ IN DRY AIR DOWN TO 1.1% WOULD RESULT IN A MIXTURE CONTAINING 17.6% O₂.
- COINCIDENTALLY, THIS HAPPENS TO BE THE AVERAGE OF THE OXYGEN ANALYSES.

POSTBURN TEMPERATURE DISTRIBUTIONS

- AVERAGE CONTAINMENT GAS TEMPERATURE CALCULATED FROM CONTAINMENT PRESSURE--SEE COMPOSITE
- OVERALL HEAT TRANSFER RATES FROM 1973 ROCKWELL SHOCK TUBE TESTS WERE USED WITH TMI-2 GAS COOLER DATA, GAS VOLUMES AND SURFACE AREAS IN CALCULATIONS WHICH CLOSELY MATCHED AVERAGE TEMPERATURES CALCULATED FROM PRESSURES.
- CALCULATED GAS TEMPERATURES ABOVE ELEVATION 347, BELOW 347, AND IN THE D-RINGS WERE CALCULATED. TEMPERATURES ABOVE ELEVATION 347 REMAINED ABOVE 900°F UNTIL COOLED BY WATER SPRAY.
- CALCULATED GAS TEMPERATURES VS. TIME AT THE GAS COOLER OUTLET AND AT VARIOUS ELEVATIONS WERE PROJECTED DOWN TO ACTUAL RECORDED TEMPERATURES (BELOW 200°F) WITH WHAT APPEAR TO BE SMOOTH TRANSITIONS.

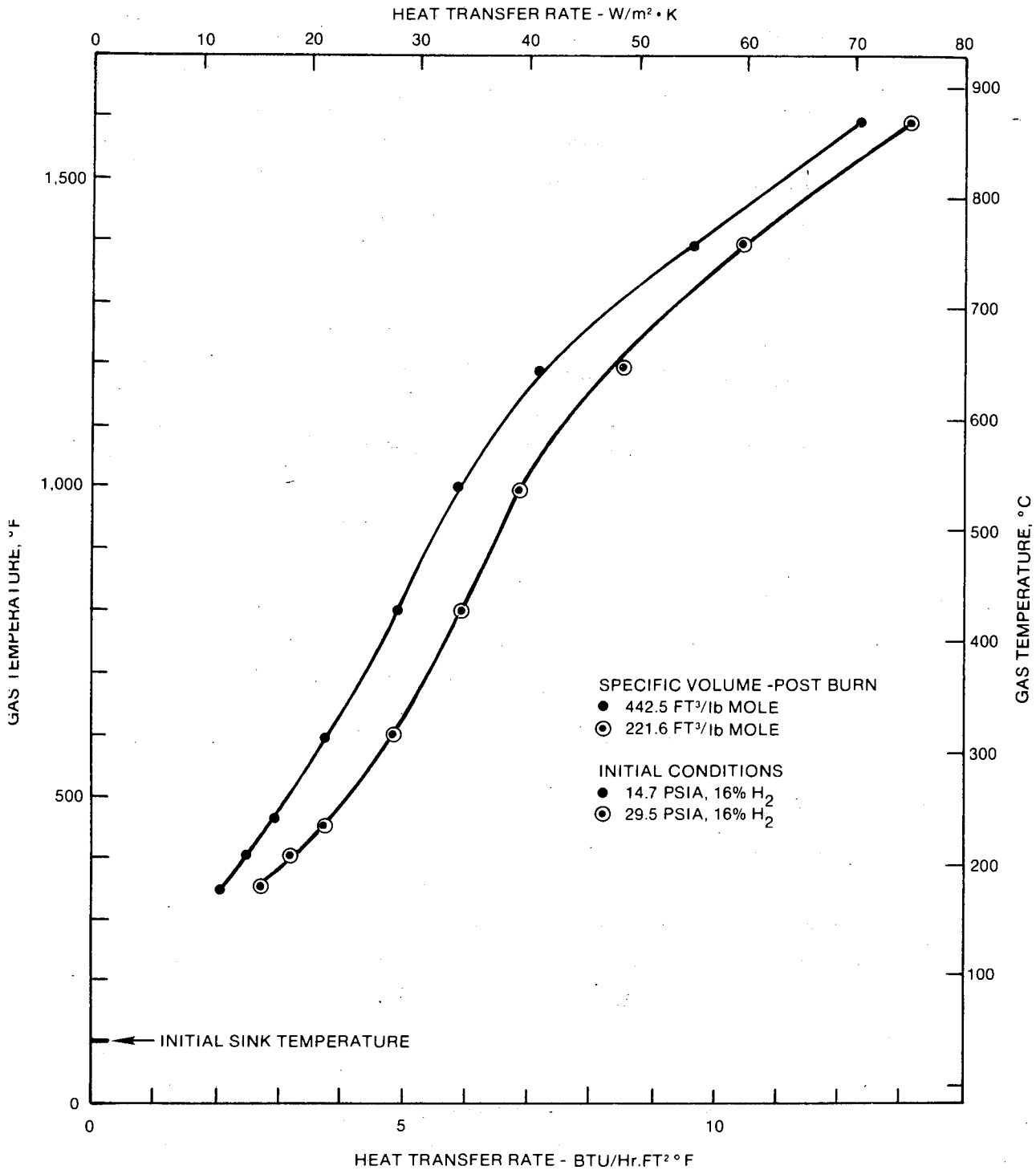

OVERALL HEAT TRANSFER RATE VERSUS
GAS TEMPERATURE FOR DIFFERENT GAS MIXTURES

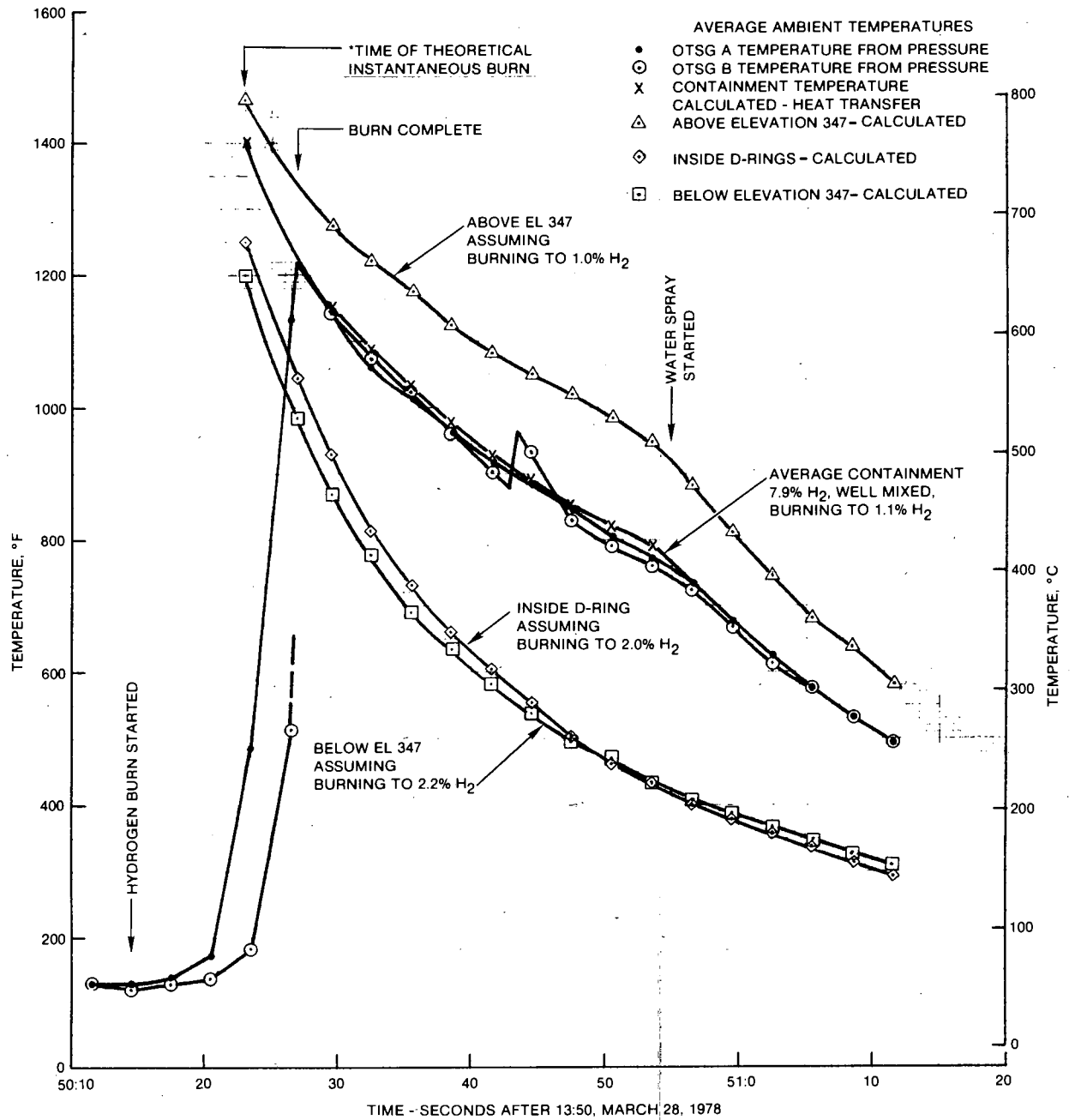

AVERAGE AMBIENT TEMPERATURE VERSUS TIME ABOVE AND BELOW ELEVATION 347, ASSUMING MORE INCOMPLETE BURNING BELOW ELEVATION 347

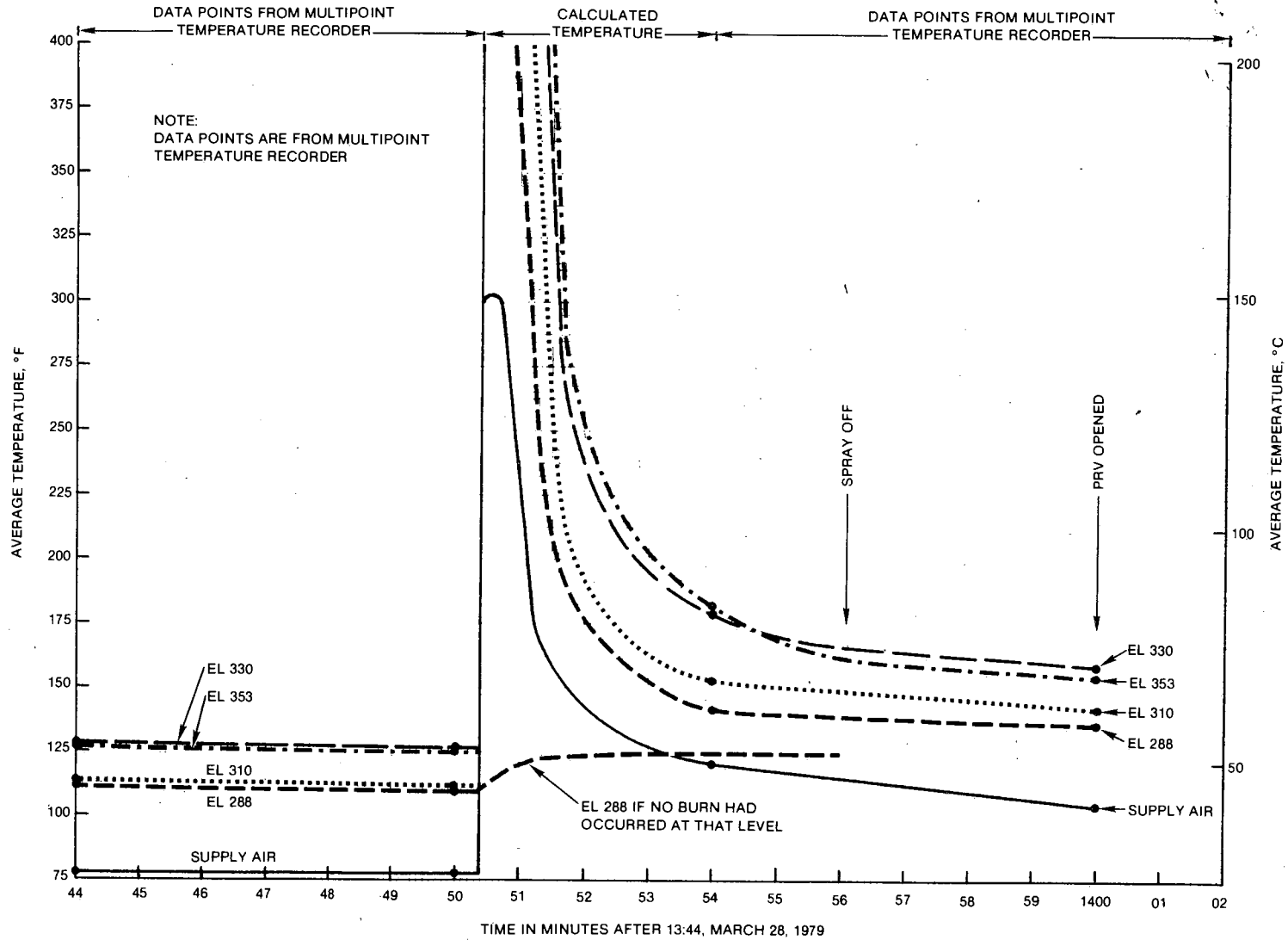

AVERAGE AMBIENT TEMPERATURE AT VARIOUS ELEVATIONS VERSUS TIME

TRANSIENT HEATING OF MATERIALS

- CALCULATIONS WERE MADE TO SHOW THE TEMPERATURE EFFECT OF THE THERMAL TRANSIENT ON DRY WOOD OF VARIOUS THICKNESSES AND PAINTED STEEL.
- THE TEMPERATURE TRANSIENT USED IN EACH CALCULATION INCREASED FROM AMBIENT TO 1400°F IN 3 SECONDS THEN FOLLOWED THE CALCULATED DECAY SLOPES ABOVE OR BELOW ELEVATION 347, AS NOTED.
- ABOVE ELEVATION 347, A THIN (1/8 INCH) WOOD SECTION REACHED MAX. TEMP. (ASSUMING NO COMBUSTION) OF APPROX. 750°F AT ABOUT 40 SEC. BELOW ELEVATION 347, IT REACHED MAX. TEMP. OF APPROXIMATELY 450°F AT ABOUT 30 SEC.
- IN 8 SECONDS, HEAT PENETRATED ABOUT 3/16 INCH INTO WOOD.
- HEAT DIFFUSES INTO PAINTED STEEL VERY RAPIDLY, WITH MOST OF THE SURFACE TEMPERATURE RISE BEING DUE TO PAINT.

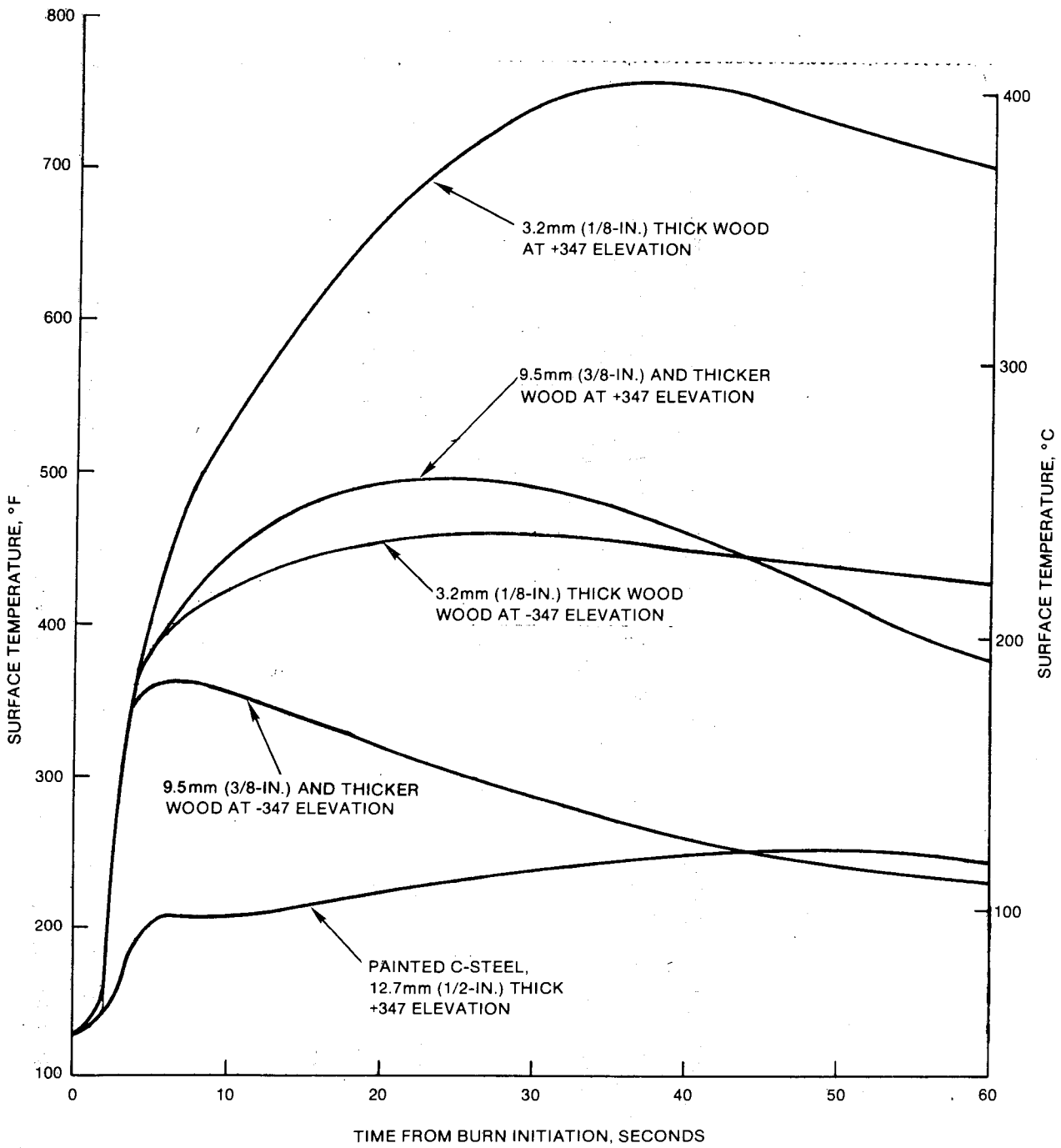

SURFACE TEMPERATURES PREDICTED FOR PLYWOOD AND PAINTED CARBON STEEL EXPOSED ON BOTH SIDES

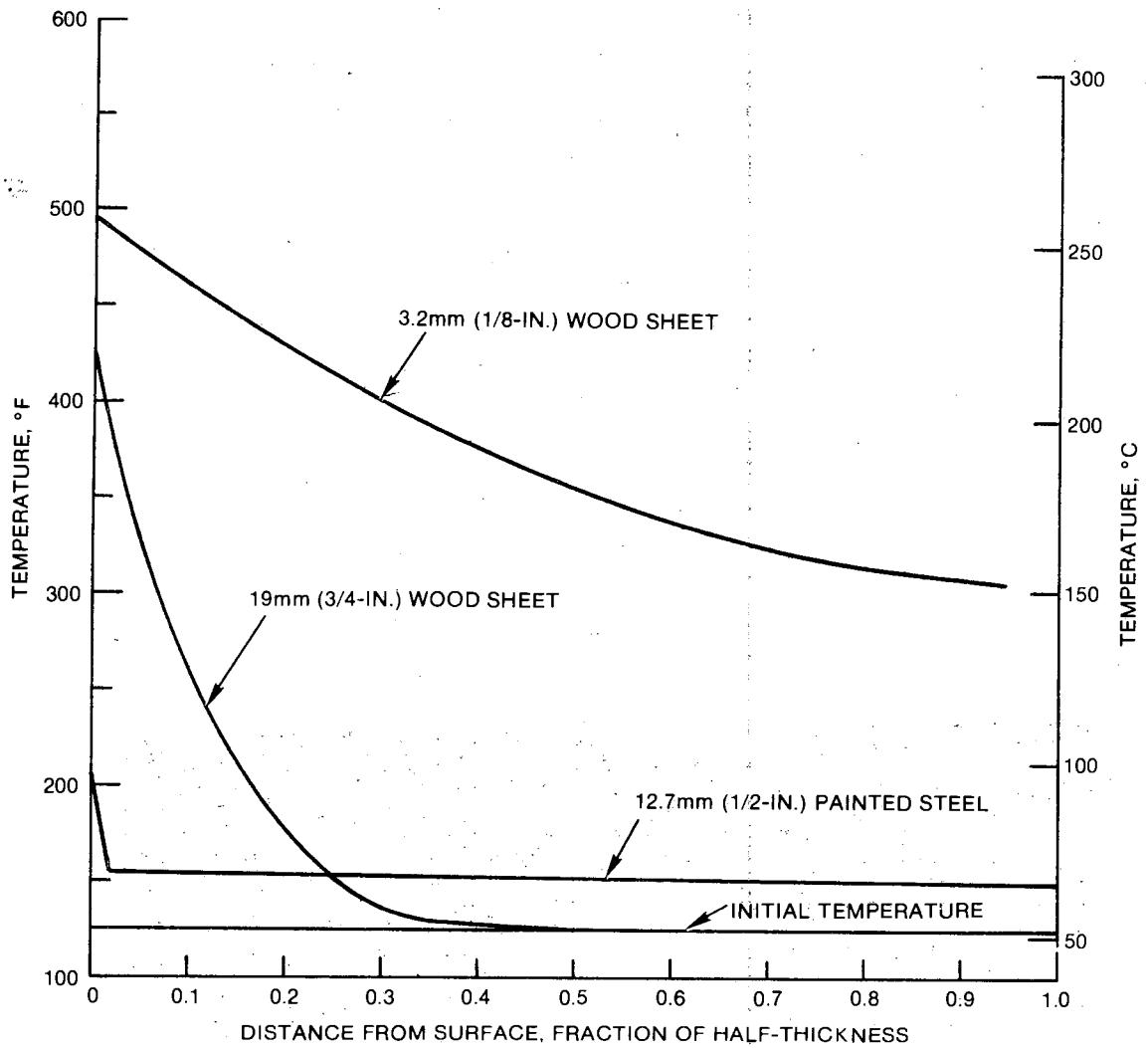

TEMPERATURE PROFILES 8 SEC AFTER BURN COMPUTED FOR MATERIALS IN UPPER CONTAINMENT BEING HEATED FROM BOTH SIDES

BURN DAMAGE

- PREDOMINANTLY AT UPPER ELEVATIONS
 - HIGHER VOLUME TO SURFACE AREA RATIO
 - MORE COMPLETE BURNING

- PREDOMINANTLY ON EAST AND SOUTH QUADRANTS
 - MATERIALS WERE WET FROM STEAM CONDENSATION IN THE WEST QUADRANT
 - D-SHIELDS ARE CLOSEST TO CONTAINMENT IN THE NORTH QUADRANT

- CHAR, MELT AND BURN DAMAGE IS LIMITED TO MATERIALS HAVING LOW THERMAL DIFFUSIVITIES, WHICH WERE NOT WET, AND WHICH HAD THE ABILITY TO CHAR, MELT OR BURN.

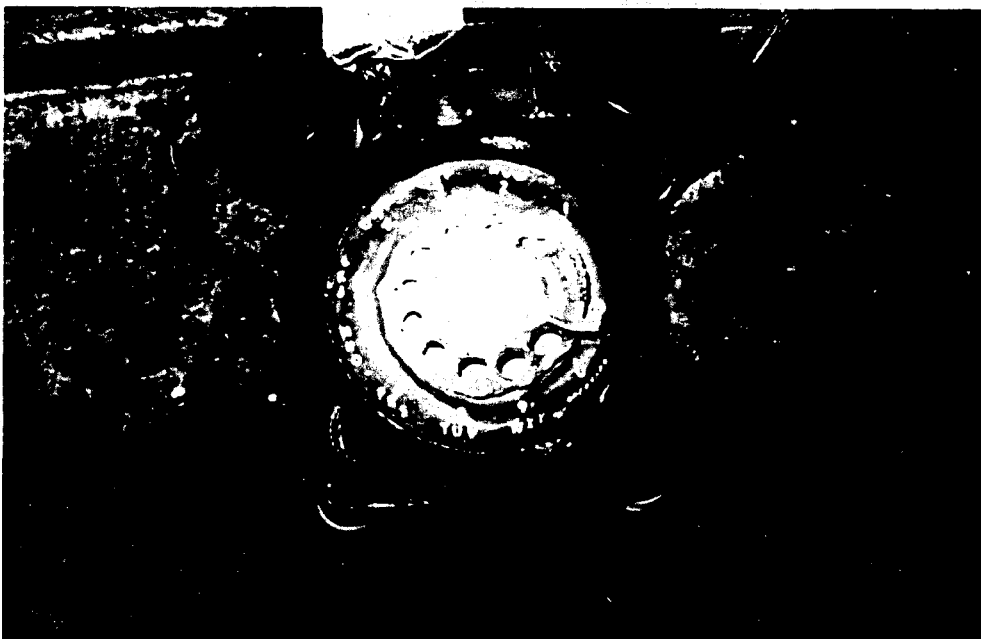

CLOSE-UP OF BELL TELEPHONE

CONTAINMENT HYDROGEN BALANCE.

TIME	HYDROGEN ADDED		HYDROGEN REMOVED		HYDROGEN INVENTORY	
	DRY (%)	KG	DRY (%)	KG	DRY (%)	KG
03/28/79						
13:50	8.2	370			8.2	370
13:52			7.1	319B	1.1	51
15:00	0.6	24A			1.7	75
04/01/79	0.5	21A			2.2	96
05/01/79	1.1	44A,C	2.6	112D	0.7	28
07/80		—	0.7	28E		0
TOTAL		459		459		

- A FROM RCS.
- B HYDROGEN BURN.
- C FROM WASTE GAS DECAY TANKS AND RADIOLYSIS.
- D ROCKWELL INTERNATIONAL HYDROGEN RECOMBINER.
- E VENTED TO ATMOSPHERE.

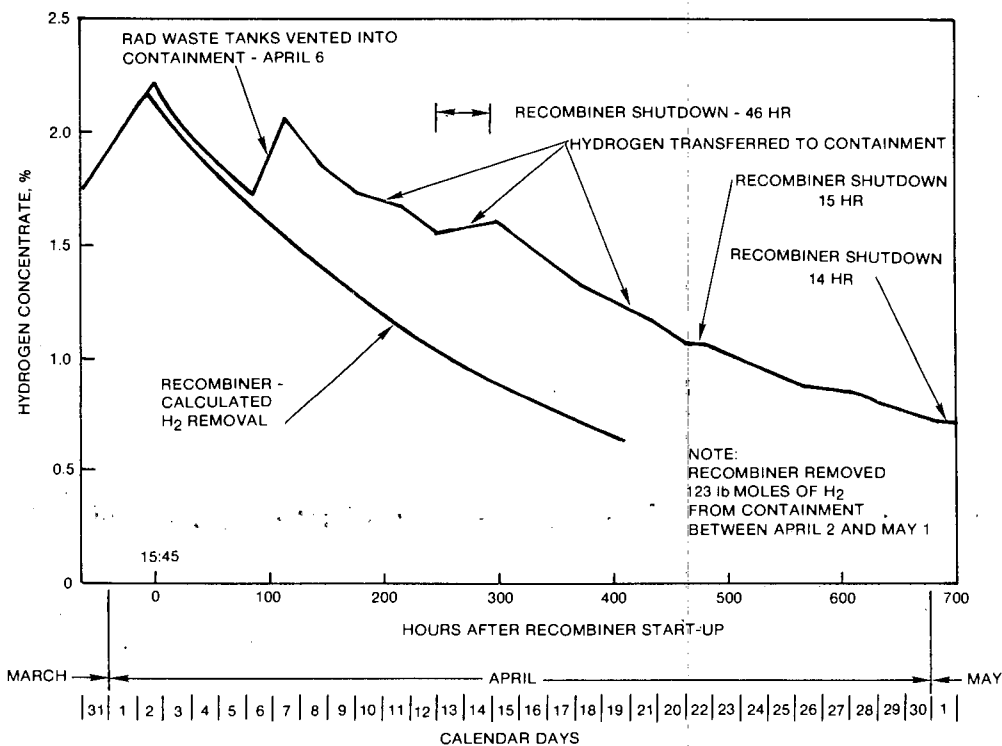

TMI UNIT 2 HYDROGEN RECOMBINER OPERATION

ZIRCONIUM OXIDATION

- APPROX. 410 KG OR 450 # MOLES OF H_2 , 90% OF TOTAL, IS ARBITRARILY ASSUMED TO HAVE BEEN GENERATED BY THE ZIRC-STEAM REACTION.
- 450 # MOLES OF H_2 IS PRODUCED BY REACTING 225 # MOLES OR 20,500 # OF ZIRCONIUM.
- TMI-2 CORE CONTAINED APPROX. 41,300 # OF ZIRC CLADDING IN CONTACT WITH ACTIVE FUEL AND APPROX. 52,000 # OF ZIRC TOTAL.
- ON THIS BASIS, 40% OF THE TOTAL CORE ZIRCONIUM OR 50% OF THE ACTIVE FUEL CLADDING WAS OXIDIZED.

TMI-2 FISSION PRODUCT CHARACTERIZATION AND DECONTAMINATION METHODS

CHARACTERIZATION OF FISSION PRODUCT DEPOSITION IN THE
TMI-2 REACTOR COOLANT AND AUXILIARY SYSTEMS:
Jack A. Daniel (SAI, Rockville),
James C. Cunnane (Battelle Columbus Laboratories)

Faint, illegible text centered on the page, possibly bleed-through from the reverse side.



CHARACTERIZATION OF FISSION PRODUCT DEPOSITION IN
THE TMI-2 REACTOR COOLANT AND AUXILIARY SYSTEMS

J. A. Daniel
Science Applications, Inc.

J. C. Cunnane
Battelle Columbus Laboratories

Characterization of the fission product and core debris deposited in the TMI-2 reactor coolant system and auxiliary systems is a key step in the recovery operations. In principle, information about the deposits on TMI-2 reactor coolant system surfaces can be obtained from experimental measurements and/or by use of analytical methods which describe the release, transport and deposition of core materials during the accident. Hence, characterization of the TMI-2 deposits also provides the industry with a unique opportunity to assess the accuracy of some of the theoretical approaches that can be used to evaluate the consequences of severe core damage accidents in risk studies. Experience to date at TMI has shown that experimental measurements are limited by the availability of suitable samples and by accessibility to key systems for in-situ measurements. On the other hand, analytical estimates are subject to unknown but probably large uncertainties. Hence, an overview of the characteristics of the deposits in the TMI-2 auxiliary systems and particularly in the reactor coolant system can, at this point, best be determined if an adequate theoretical understanding of how these deposits were formed is used to support reasonable extrapolations and interpretations of the data that are available.

This paper presents the results of EPRI efforts to characterize the deposits in the TMI reactor coolant and auxiliary systems using experimental and analytical approaches. The experimental work included the analysis of samples and in-situ gamma spectroscopic measurements. The analytical work included an analysis of the radionuclide inventory in the core at the time of the accident and estimation of the release and dispersion of core

materials in the primary coolant system during the accident. Significant comparisons between the experimental and theoretical results will be presented. In addition, this paper identifies some correlations between radionuclides which are easy to identify and those which can only be identified by complicated laboratory chemical separation techniques.

The radionuclide inventory in the TMI-2 core at the time of the accident was determined using the ORIGEN and LOR 2 codes. The Babcock & Wilcox code, LOR 2, is a modified version of ORIGEN which takes into consideration the concentration of boron in the coolant and its impact on the neutron population. Measurement data from TMI-2 has shown that by using the same power history, a combination of LOR 2 and ORIGEN most accurately reflects the true fission product and transuranic inventory. Specific differences between the predictions of these codes will be discussed in the light of the TMI-2 experimental data.

The TMI-2 source term was estimated using NUREG-0772 release rate coefficients together with a reasonable estimate for the core temperature distribution for the critical phase of the accident between 113 and 208 minutes after the reactor tripped. The source term estimates, together with the deposit distribution in the reactor coolant system, will be discussed in the presentation. It has been found that measurements of the deposit distribution are facilitated by the observation that certain fission product isotopes, such as Ce-144, are so insoluble that they serve as "flags" for indication and measurement of fuel debris by direct gamma ray spectroscopy.

Data from in-situ measurements and samples used to characterize TMI-2 deposits will be presented. The implications of this data for support of the TMI-2 recovery operations and for assessing the adequacy of current source term estimates and deposition models will also be discussed.

FISSION PRODUCT TRANSFER IN THE TMI-2 PURIFICATION SYSTEM:
T. E. Cox (EG&G Idaho, Inc.)

1948

FISSION PRODUCT TRANSFER IN THE TMI-2 PURIFICATION SYSTEM*

T. E. Cox, EG&G Idaho, Inc.

The makeup purification system at TMI-2 operated during the course of the accident, processing water from the reactor coolant system cold leg at an average flow rate not exceeding $4.4 \times 10^{-3} \text{ m}^3/\text{s}$. The system operated through most of 28 March 1979, finally being shutdown when the system filters or demineralizers, or both, plugged and overpressured. The system was restored to service on 29 March 1979 at a flow rate of about $1.6 \times 10^{-3} \text{ m}^3/\text{s}$. Subsequent radiation readings of the system filters and demineralizer cubicles revealed that these components contained appreciable levels of radionuclides.

One project being implemented within the Radiation and Environment Program of the Technical Integration Office is to analyze the demineralizer resins and filters, as they are removed from the makeup purification system. The object is to determine the quantity and composition of the material retained by the resins and filters. In 1982, approximately 3 g of solid material were obtained from Makeup Filter 5B (MUF-5B), during an unsuccessful attempt to remove the filter from the system. Filter set MUF-5A and -B represents the first point of filtration for the water from the reactor coolant system cold leg. Fractions of these solids were analyzed for elemental and radionuclide content at the Babcock & Wilcox (B&W) Laboratory at Lynchburg, Virginia, and by EG&G Idaho, Inc. at the Idaho National Engineering Laboratory (INEL). Selected portions of the

* Work supported by the U.S. Department of Energy, Assistant Secretary for Nuclear Energy, Office of Coordination and Special Projects, under DOE Contract No. DE-AC07-76ID01570.

data from the analyses performed on the solids by EG&G Idaho are shown in Table 1. The data are comparable, within the experimental error, with preliminary results from the B&W analyses.

The data indicate that the filter solids contain quantities of mixed fission products, fuel (U), control materials (Ag, In, Cd, and C), cladding (Zr), and structural material (Cr, Fe, Ni, and Sn). The predominant fraction of particle size of this material is 1 to 5 μm . There were some larger particles noted in the sample that appear to be agglomerations of smaller particles. These agglomerations may be the result of charge attraction, since the sample displayed some magnetic properties. Evidence of melting was not noted during the examination of the particles. Evidence from examinations using a molecular optical laser examiner did show indications of Zr phase changes. The isotopic concentration of the uranium in the sample is about 2.4% ^{235}U and about 97.6% ^{238}U , which is very similar to the average value (2.53% ^{235}U) of the original fuel loading.

It appears that the damage occurring during the core temperature transient associated with the accident at TMI-2 involved most, if not all, of the types of the materials in the core. Examination of the materials analyzed shows no evidence of melting, but it does reveal fracture of the materials, possibly along grain boundaries. The source for the material found in the makeup purification system was the cold leg of the reactor coolant system, which implies that similar core material is dispersed throughout the reactor coolant system.

TABLE 1. MAKEUP FILTER 5B DEBRIS ANALYSES

(Performed on 1.5 g of homogenized sample)

Fission Products		Elemental ^a		Fuel ^b	
Nuclide	Concentration (Bq/g)	Element	Wt%	Nuclide	Wt%
⁵⁴ Mn	6.29 ± 0.74E+5	Zr	5.4	²³⁵ U	0.12
⁶⁰ Co	7.40 ± 1.85E+6	Cr	1.0	²³⁸ U	4.88
¹⁰⁶ Ru/Rh	2.07 ± 0.11E+7	Fe	5.7	Pu	0.01
^{110m} Ag	1.78 ± 0.15E+6	Ni	4.9		
¹¹³ Sn	2.22 ± 1.11E+5	Sn	2.3		
¹²⁵ Sb	9.99 ± 0.37E+7	Ag	11.1		
¹³⁴ Cs	1.48 ± 0.04E+7	In	5.7		
¹³⁷ Cs	1.44 ± 0.04E+8	Cd	11.4		
⁹⁰ Sr	1.52 ± 0.04E+8				

a. Elements Si, B, Mn, Ti, Al, Mo, Mg, Nb were also found in the sample at 1 Wt%.

b. Levels of ²³⁴U, ²³⁶U, ²³⁸pu, ²³⁹pu, ²⁴⁰pu, ²⁴¹pu, and ²⁴²pu were present in the sample.

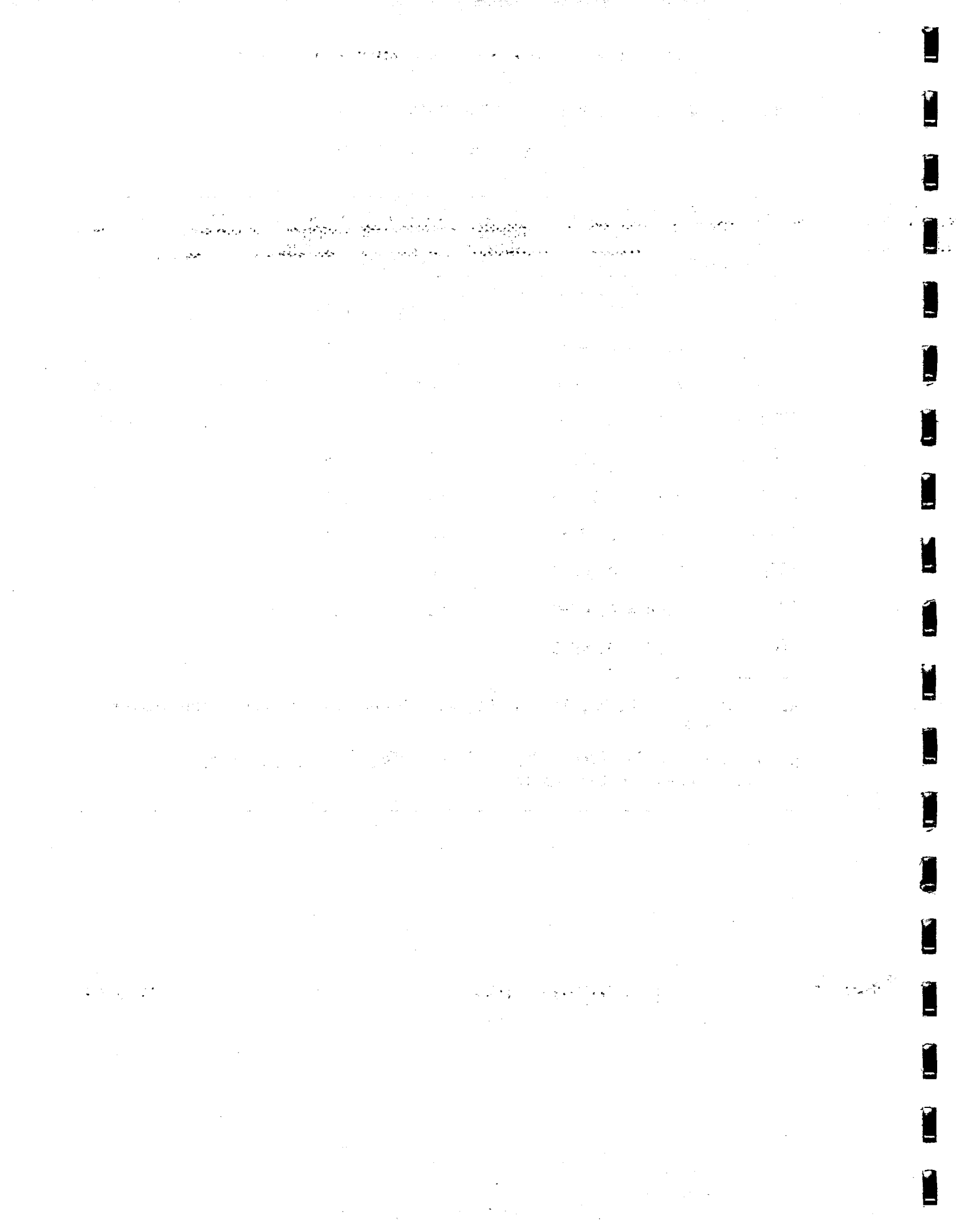

TMI-2

Fission Product Transfer in the Purification System

T. E. Cox

Technical Coordinator
Radiation and Environment

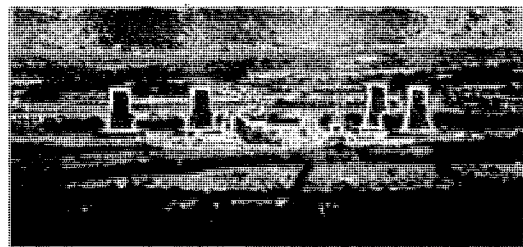
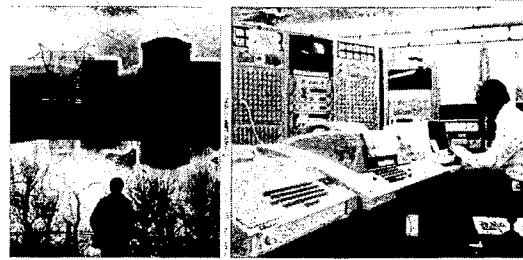
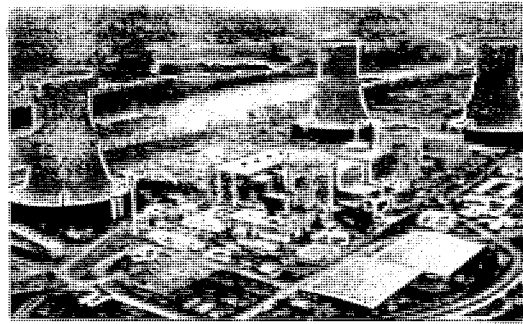

Make-Up Filter: MUF-5B

Overall size: 6 in. x 24 in.

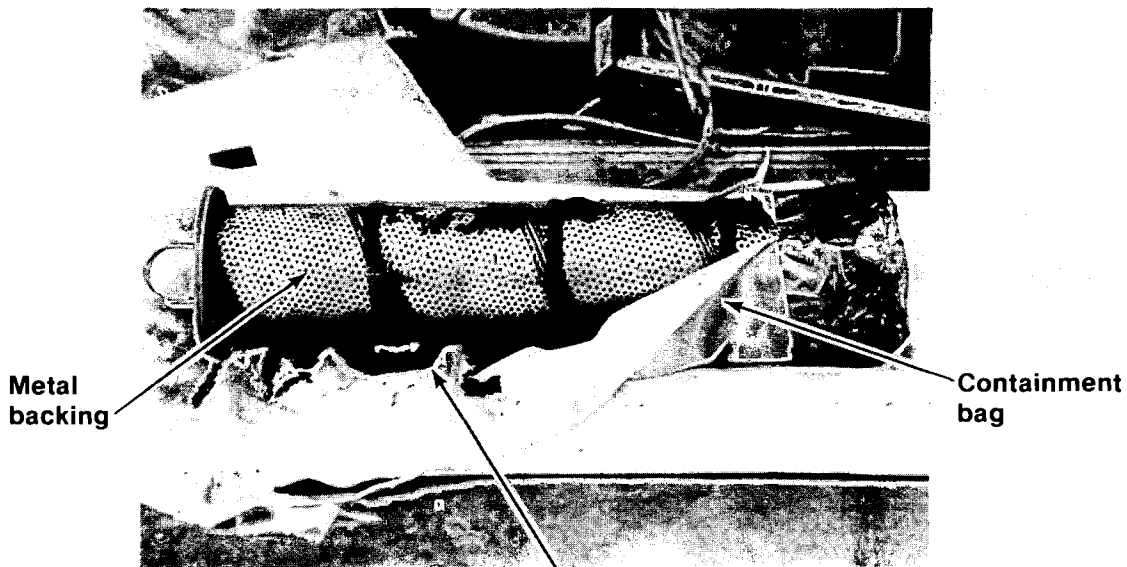

82-0058

S2 9892

Make-Up Filter: MUF-5B

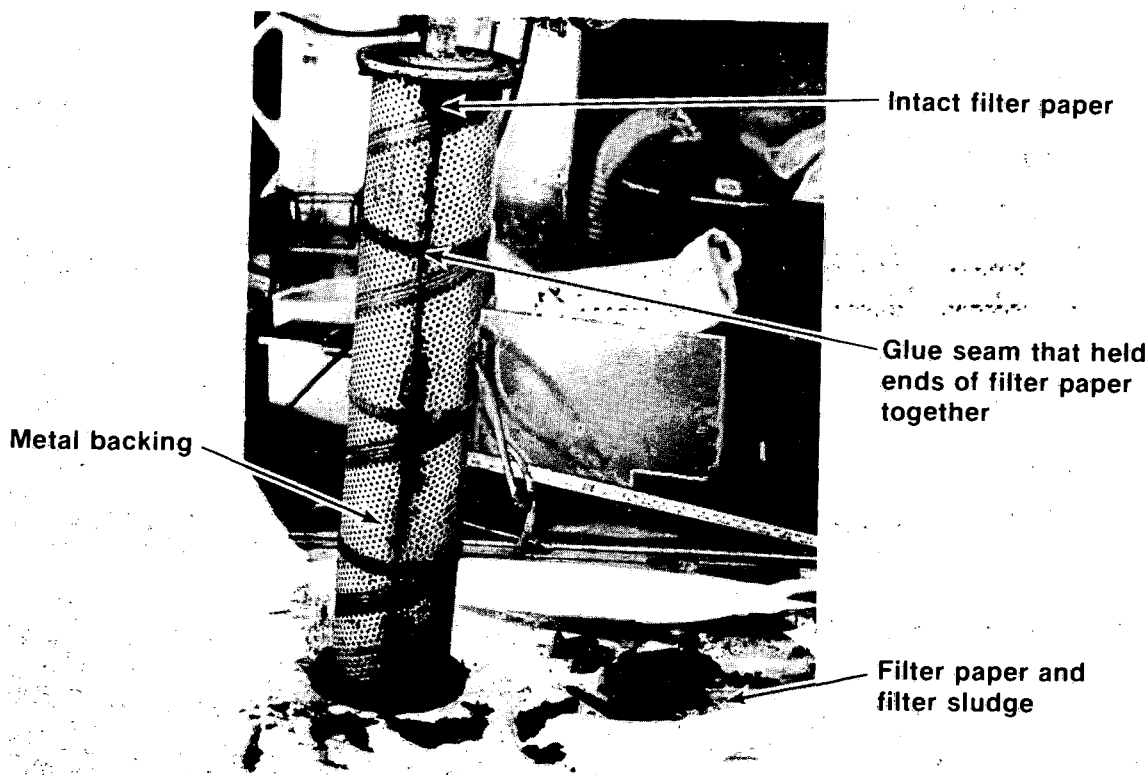

82-0065

S2 9893

MUF-5B Fission Product Concentrations (1.5g homogenized sample)

<u>Fission product</u>	<u>Concentration</u> <u>$\mu\text{Ci/g}$</u>
^{125}Sb	$2.7 \pm 0.1 (+3)$
^{134}Cs	$4.0 \pm 0.1 (+2)$
^{137}Cs	$3.9 \pm 0.1 (+3)$
$^{144}\text{Ce/Pr}$	$9.5 \pm 0.2 (+2)$
^{90}Sr	$4.1 \pm 0.1 (+3)$

MUF-5B Fission Product Concentrations

(1.5g homogenized sample)

<u>Fission product</u>	<u>Concentration $\mu\text{Ci/g}$</u>
^{54}Mn	1.7 \pm 0.2 (+ 1)
^{60}Co	2.0 \pm 0.5 (+ 2)
$^{106}\text{Ru/Rh}$	5.6 \pm 0.3 (+ 2)
$^{110\text{m}}\text{Ag}$	4.8 \pm 0.4 (+ 1)
^{113}Sn	6.0 \pm 3.0 (0)

S2 3646

MUF-5B Fuel Weight Percents (1.5g sample)

<u>Fuel</u>	
<u>Nuclide</u>	<u>Wt%</u>
^{235}U	0.12
^{238}U	4.88
Pu	0.01

Also present:

$^{234,236}\text{U}$ $^{238,239,240,241,242}\text{Pu}$

S2 3645

**MUF-5B Element Weight
Percents
(1.5g sample)**

<u>Element</u>	<u>Wt%</u>	<u>Element</u>	<u>Wt%</u>
Zr	5.4	Ag	11.1
Cr	1.0	In	5.7
Fe	5.7	Cd	11.4
Ni	4.9	C	17.5
Sn	2.3		

S2 3647

**MUF-5B Element Weight
Percents
(1.5g sample)**

<u>Element</u>	<u>Wt%</u>	<u>Element</u>	<u>Wt%</u>
Si	<1	Al	<1
B	<1	Mo	<1
Mn	<1	Mg	<1
Ti	<1	Nb	<1

S2 4009

Vacuum Filter MUF-5B

Overall size: 2-1/2 in. x 10 in.

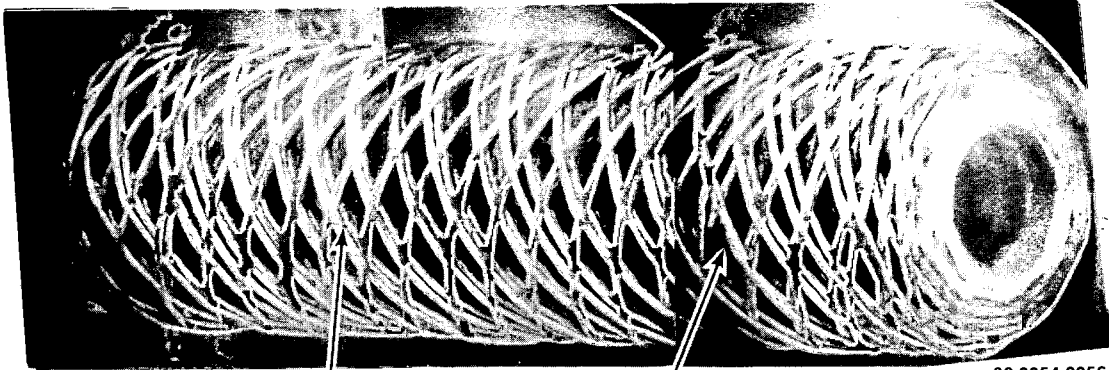

82-0054-0056

Coarse particulate debris

Fine particulate debris (dark area)

S2 9895

Make-Up Filter: MUF-2A



Metal backing

Filter paper and filter sludge

Filter paper and filter sludge

82-0059

S2 9894

1. The first part of the document discusses the importance of maintaining accurate records of all transactions. It emphasizes that this is essential for ensuring the integrity of the financial data and for facilitating the audit process. The text notes that any discrepancies or errors in the records can lead to significant complications and may result in legal consequences.

2. The second part of the document outlines the specific procedures that must be followed when recording transactions. It details the requirements for the format and content of the records, including the need for clear descriptions of the transactions and the dates on which they occurred. The text also discusses the importance of maintaining these records in a secure and accessible manner.

3. The third part of the document addresses the issue of the retention of records. It specifies the minimum period for which records must be kept and provides guidance on how to manage the records during this period. The text highlights the need to ensure that the records are easily retrievable and that they are protected from loss or damage.

4. The final part of the document provides a summary of the key points discussed and offers some concluding remarks. It reiterates the importance of compliance with the requirements and encourages the reader to take the necessary steps to ensure that all transactions are properly recorded and maintained. The text concludes by stating that adherence to these guidelines is essential for the successful operation of the business and for the protection of the interests of all stakeholders.



ANALYSIS OF TMI-2 SAMPLES USING THE
MOLECULAR OPTICAL LASER EXAMINER:
T. E. Doyle, J. L. Alvarez (EG&G Idaho, Inc.)

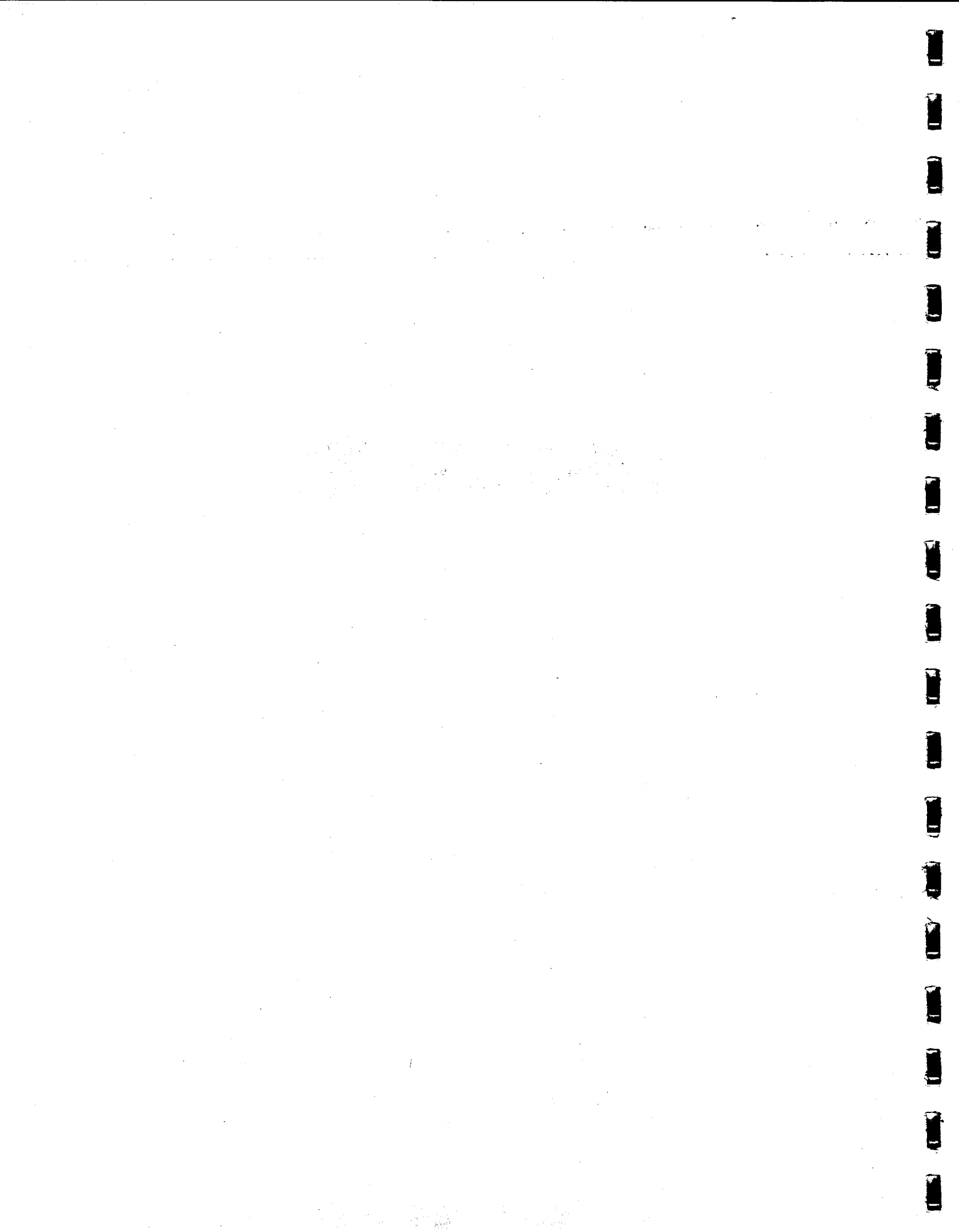

ANALYSIS OF TMI-2 SAMPLES USING THE
MOLECULAR OPTICAL LASER EXAMINER*

T. E. Doyle, EG&G Idaho, Inc.

J. L. Alvarez, EG&G Idaho, Inc.

The Molecular Optical Laser Examiner (MOLE) uses micro-Raman spectroscopy to identify the chemical species and crystalline states of sample particles. The purpose of examining TMI-2 samples with the MOLE is threefold: to determine the various chemical species resulting from a nuclear release accident; to better explain the presence, transport, and consequences of release to the environment of specific chemical species; and to clarify and define the accident scenario. One result from the work will be discussed in this paper: the positive identification of zirconium oxide, and particles that produce spectra characteristic of ZrO_2 , in the TMI-2 makeup and purification system. Spectra of the latter particles reveal differences from the ZrO_2 in crystalline structure, composition, or both, that may provide information about processes that occurred in the TMI-2 core.

The samples in which the ZrO_2 was found were obtained from Makeup Filter MUF-5B, one of two makeup and purification demineralizer filters. Since the sample stage is a conventional light microscope, no special preparation was needed to examine the particles beyond mounting the sample on a glass slide.

Monoclinic zirconium oxide was first discovered as a light gray, oval particle, 6 μm by 8 μm . The particle's spectrum closely matched a reference spectrum; nine of the 13 peaks positively resolved.¹ The four unresolved peaks coincided with the plasma lines of the 488.0-nm blue line of the argon laser.

* Work supported by the U.S. Department of Energy, Assistant Secretary for Nuclear Energy, Office of Coordination and Special Projects, under DOE Contract No. DE-AC07-76ID01570.

A second particle, white, square, 6 μm by 8 μm , produced a spectrum identifying ZrO_2 , but not initially in a monoclinic crystalline state. The first spectrum taken of the particle displayed weak, broad lines at 256 cm^{-1} , 465 cm^{-1} , and 628 cm^{-1} , suggesting a strained cubic crystalline structure.² The 180 cm^{-1} and 192 cm^{-1} lines of the tetragonal and monoclinic phases were missing. Subsequent spectra showed the particle undergoing a phase transformation. The monoclinic phase became more dominant with successive spectra. Heating from the laser is believed to have induced this phase transformation. The final spectrum was not entirely monoclinic but showed a disparity in the relative heights of the 337 cm^{-1} and 476 cm^{-1} line, and a weak line at 216 cm^{-1} was not found in the standard spectrum. In addition, the major monoclinic lines of the intermediate spectra were shifted to high frequencies (lower wave numbers). The 180 cm^{-1} line was shifted to 173 cm^{-1} , the 192 cm^{-1} line to 184 cm^{-1} , and the 476 cm^{-1} line to 465 cm^{-1} . The intermediate spectra also showed a strong peak at 255 cm^{-1} , not a monoclinic line.

A third particle, light gray, irregular, 5 μm by 8 μm , produced a spectrum not corresponding to a pure monoclinic, tetragonal, or cubic state, although the spectrum most closely resembled that of monoclinic ZrO_2 . The 250 cm^{-1} and 263 cm^{-1} lines identifying the cubic and tetragonal phases, respectively, were missing. But there was again a disparity in the relative peak heights. Again, the peaks were displaced to lower wave numbers on the first and subsequent spectra.

The origin of these particles is of considerable interest. Since ZrO_2 is insoluble in either cold or hot water, the particles most likely originated in the TMI-2 core and were transported by suspension. The existence of monoclinic ZrO_2 in the makeup and purification system is not a surprise, since a large portion of the zircaloy fuel-rod cladding is believed to have oxidized, and the most stable form of ZrO_2 below 1000°C is monoclinic.

However, ZrO_2 in a cubic or transitional phase has also been discovered. Cubic and tetragonal ZrO_2 are unstable at low temperatures; the ZrO_2 must be locked into the cubic or tetragonal state by the presence of an impurity (e.g., Y_2O_3 or CaO). Three possible explanations are being considered and work is continuing in an effort to account for the results:

1. The particles are fragments of the ZrO_2 ceramic spacers in the core. The fragments have been subjected to stresses (i.e., heat and pressure) that have caused phase changes.
2. The ZrO_2 in the particles is in a solid solution. Eutectics may have formed from zirconium and constituents from the fuel and control rods, subsequently oxidizing or forming in the oxidized state.
3. Oxidized zircaloy samples that have been studied show two types of ZrO_2 spectra, corresponding to slowly oxidized and rapidly oxidized zircaloy. Slowly oxidized samples displayed a monoclinic spectrum with lines shifted to lower wave numbers and some differences in peak intensities. Rapidly oxidized samples produced the standard monoclinic spectrum. Tetragonal structure was not indicated in either case.

REFERENCES

1. V. G. Keramidas and W. B. White, "Raman Scattering Study of the Crystallization and Phase Transformations of ZrO_2 ," Journal of the American Ceramics Society, 57 [1], 23 (1974).
2. C. M. Phillippi and K. S. Mazdidasni, "Infrared and Raman Spectra of Zirconia Polymorphs," Journal of the American Ceramics Society, 54 [5], 257 (1971).

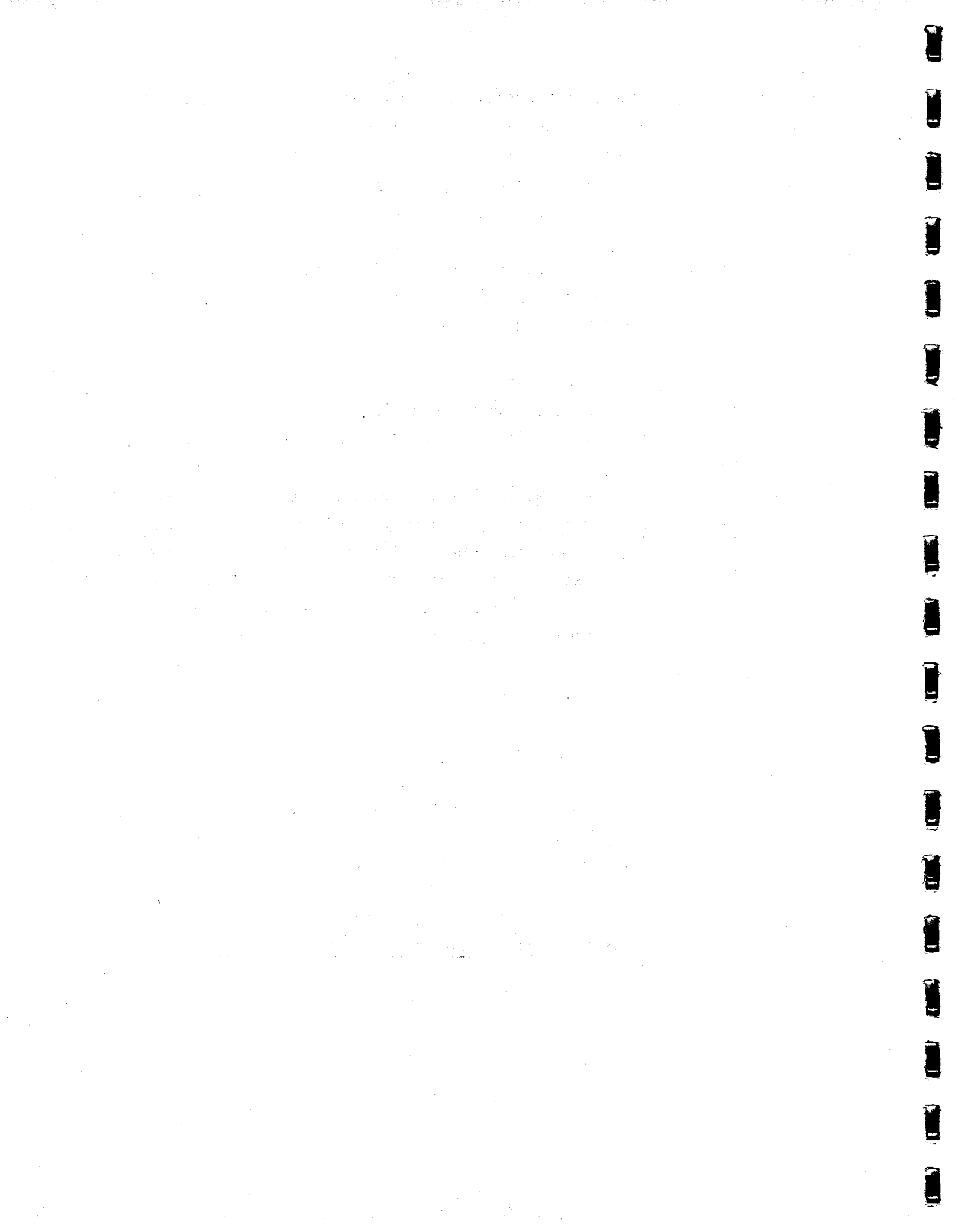

Results

- ZrO_2 identified in TMI-2 purification system
- ZrO_2 - oxidized fuel-rod cladding
- Crystalline structure may yield information about processes in TMI-2 core

S2 3969

Particle No. 1

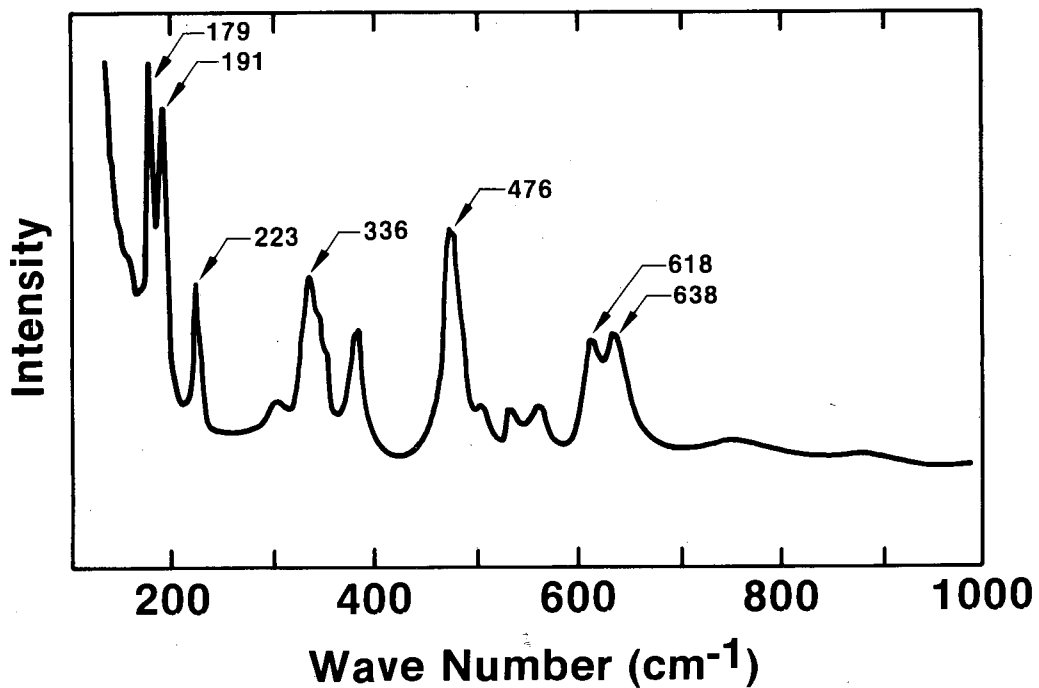

S2 3972

Monoclinic ZrO₂

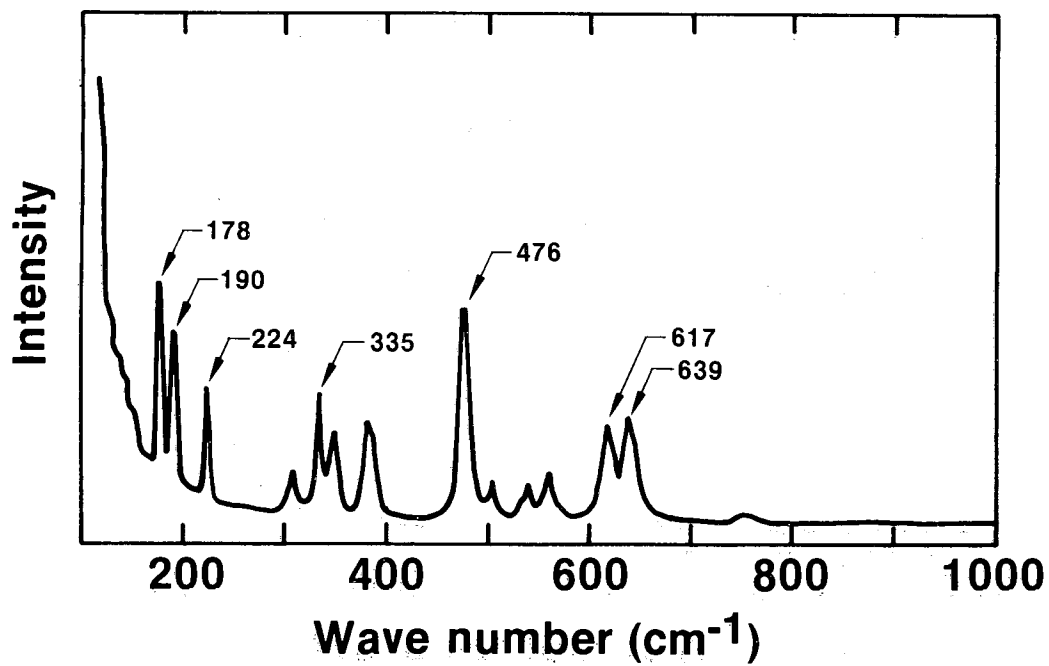

S2 3971

Particle No. 2

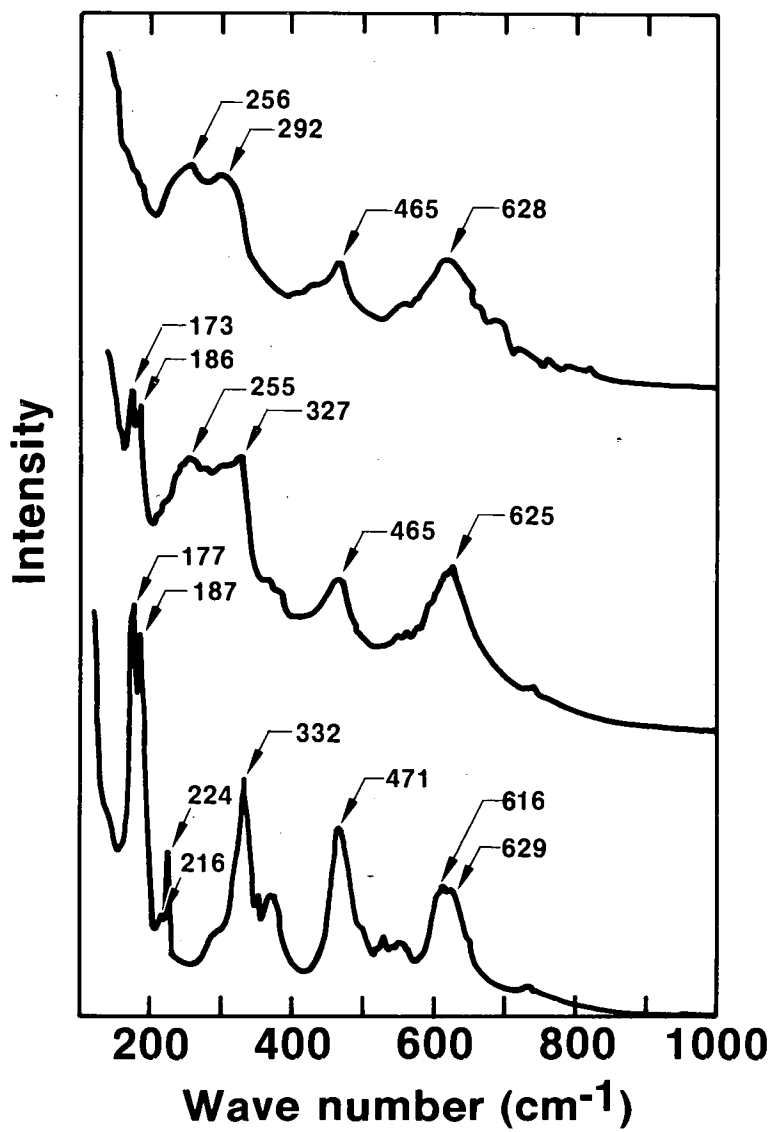

S2 3970

Particle No. 1

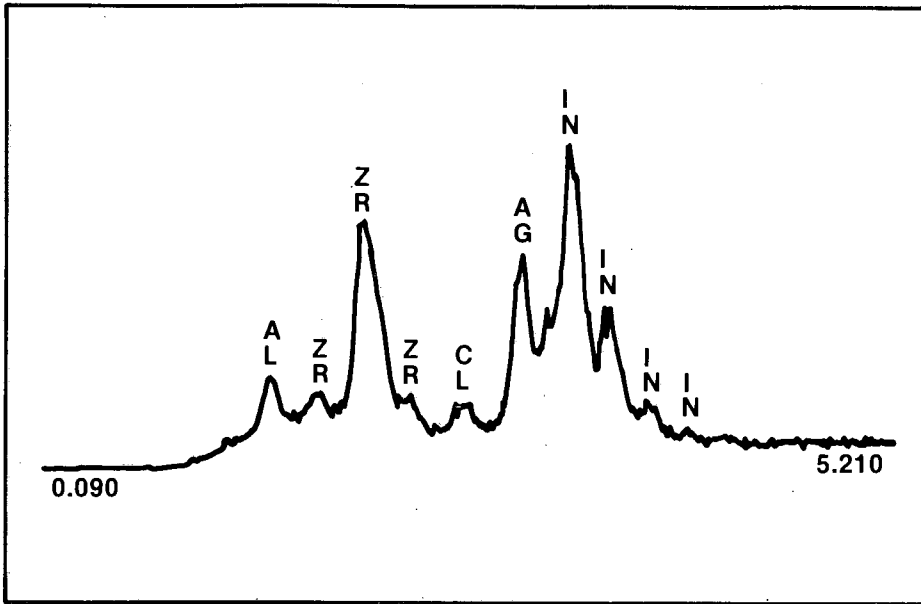

S2 3973

Particle No. 2

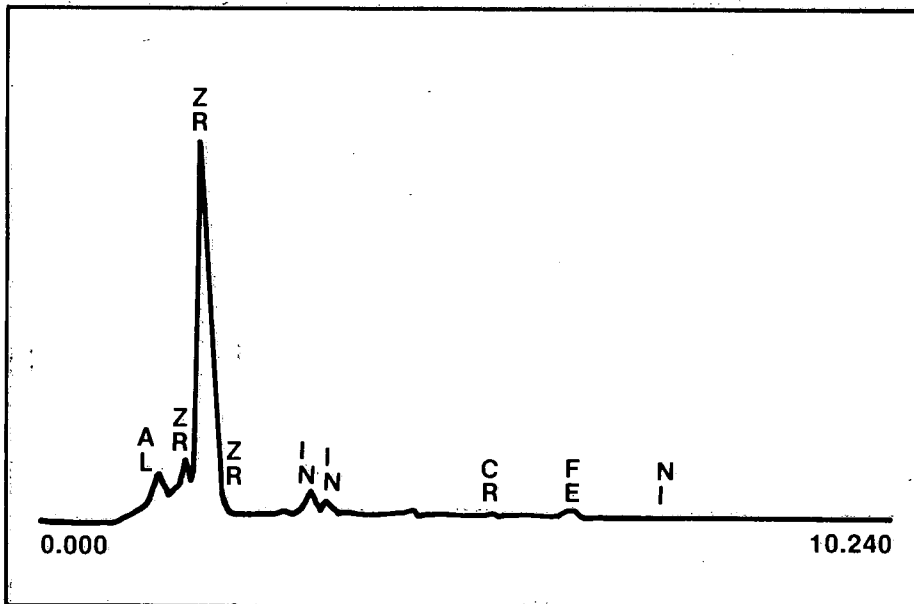

S2 3974

Summary

- ZrO_2 identified in purification system
- ZrO_2 - oxidized fuel-rod cladding
- Tetragonal phase suggests temperatures in core exceeded 1200° C .
- Tetragonal phase metastably locked by
 - Quenching
 - Impurities
 - Particle size

1944

1944

1944

1944

1944

1944

1944

1944

1944

1944

PRELIMINARY RESULTS OF THE TMI-2
RADIOACTIVE IODINE MASS BALANCE STUDY:
C. A. Pelletier (SAI, Rockville),
T. E. Cox, D. L. Reeder (EG&G Idaho, Inc.),
P. G. Vollique, C. O. Thomas (SAI, Rockville)

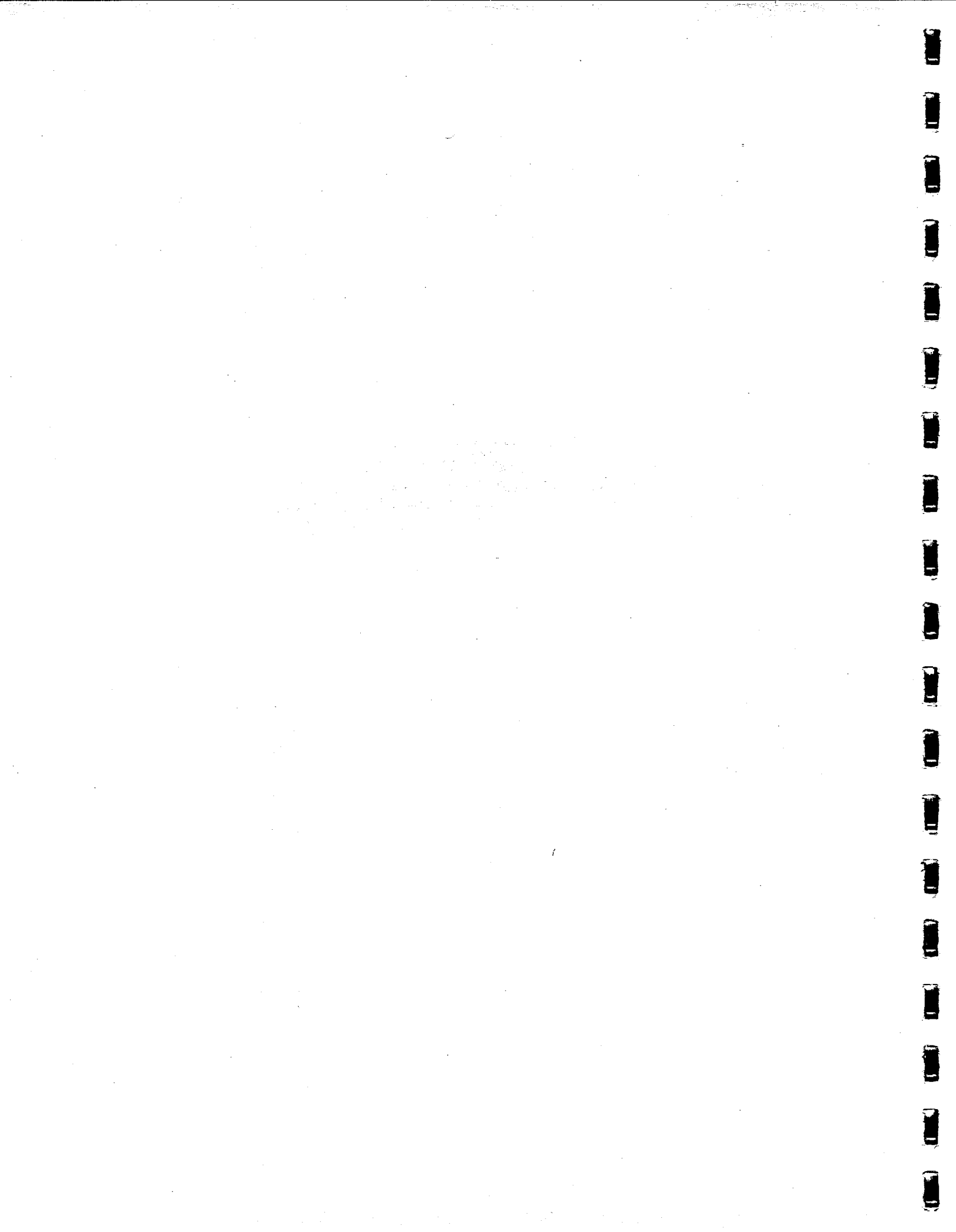

PRELIMINARY RESULTS OF THE TMI-2 RADIOACTIVE IODINE MASS BALANCE STUDY*

C. A. Pelletier, Science Applications, Inc.

T. E. Cox, EG&G Idaho, Inc.

D. L. Reeder, EG&G Idaho, Inc.

P. G. Vollique, Science Applications, Inc.

C. D. Thomas, Science Applications, Inc.

Analysis of samples taken from the Three Mile Island Unit 2 (TMI-2) reactor building following the 1979 accident^{1,2,3,4} indicates the fraction of the radioactive iodine (radioiodine) inventory in the core released to the building atmosphere is smaller than assumed in Regulatory Guide 1.4.⁵ This summary presents analytical results supporting this conclusion.

While the first sampling of the reactor coolant system (RCS), auxiliary building atmosphere, and reactor building (RB) atmosphere occurred in the three days immediately following the March 28, 1979 accident, the first RB basement liquid samples were not obtained until August 28, 1979. Also in August, additional samples were obtained from the RCS, the auxiliary building atmosphere, and the RB atmosphere. Table 1 summarizes results of analyses performed on samples taken during August 1979.

Analytical models were used to estimate how much radioiodine was present in various locations from the time of the March accident through August 1979. The analytical models contained empirical coefficients,

* Work supported by the U.S. Department of Energy, Assistant Secretary for Nuclear Energy, Office of Coordination and Special Projects, under DOE Contract No. DE-AC07-76ID01570.

determined by comparing the models with data from the accident and other experimental data. The models were used to estimate the amount of radioiodine in the RCS, on RB surfaces, in the RB atmosphere, and in the basement.

The analytical models used to estimate amounts of radioiodine in the RCS accounted for fission product release rates from the fuel, plateout on reactor vessel internals, concentration of fission products in the reactor coolant, and discharge of coolant from the RCS. Results of RCS calculations of drain tank relief valve and rupture disk reactor coolant flow, iodine concentrations, and enthalpy were used as input to the RB radioiodine transport calculations. Analytical techniques were used to model radioiodine transport processes in the reactor building. These processes included deposition on and resuspension from surfaces; gaseous and liquid iodine transport; mass transfer controlled by partitioning; chemical reactions on surfaces; and transport in condensate.

The accompanying figures present results of the transport calculations. The maximum calculated RB atmosphere radioiodine concentration represents 0.2% of the core inventory. The transport calculation was normalized to the maximum measured value of surface contamination, which represents 0.7% of the core inventory. Based on the calculations and sensitivity studies, much of the radioiodine released into the RB was most likely discharged directly to the basement and was not airborne. Transport calculation results indicate that airborne and surface activities measured after the accident did not evolve from the basement following the accident but resulted from releases directly into the RB atmosphere during the accident. Based on the measured iodine activity in the RB atmosphere 75 hours after the accident and the known behavior of organic iodine, an upper bound of 0.009% of the core radioiodine inventory for airborne organic iodine was established.

Sample analyses and calculations based on those analyses revealed information pertinent to understanding radioiodine release, transport, and deposition during an accident involving core damage in a full-size pressurized water reactor. Specifically:

1. Results indicate that about five months following the accident between 17 and 28% of the radioiodine fuel inventory could be accounted for in the reactor and auxiliary buildings and RCS.
2. The highest measured concentration of radioiodine in the RB atmosphere represented 0.03% of the core inventory, whereas the highest calculated concentration represented 0.2% of the core inventory. Both values are much less than the 25% of core inventory value assumed for the design basis accident in Regulatory Guide 1.4.
3. The maximum possible concentration of organic radioiodine activity represents 0.009% of the core inventory, which is much less than the 1% value specified in Regulatory Guide 1.4 or the 0.7% value used in WASH-1400.

TABLE 1. SUMMARY OF MEASURED RADIOIODINE INVENTORIES FIVE MONTHS AFTER ACCIDENT (August 28, 1979)

<u>Location</u>	<u>Percent of Initial Core Iodine Inventory</u>
Reactor coolant system	2-3
Reactor building sump	12-19
Reactor building atmosphere	0.002-0.003
Reactor building surfaces	0.5-0.7
Auxiliary building liquids	<u>2-5</u>
TOTAL ACCOUNTED FOR	17-28

REFERENCES

1. Nuclear Safety Analysis Center, Analysis of Three Mile Island Unit 2 Accident, NSAC-80-1, March 1980.
2. J. E. Cline et al, Measurements of I-129 and Radioactive Particulate Concentrations in the TMI-2 Containment Atmosphere During and After the Venting, GEND-009, April 1981.
3. D. H. Meikrantz et al, First Results of TMI-2 Sump Sample Analyses--Entry 10, GEND-INF-011, July 1981.
4. C. A. Pelletier et al, Iodine-131 Behavior During the TMI-2 Accident, NSAC-30, November 1981.
5. U.S. Atomic Energy Commission, "Assumption Used for Evaluating the Potential Radiological Consequences of a Loss of Coolant Accident for Pressurized Water Reactors," Regulatory Guide 1.4, Revision 2, June 1974.

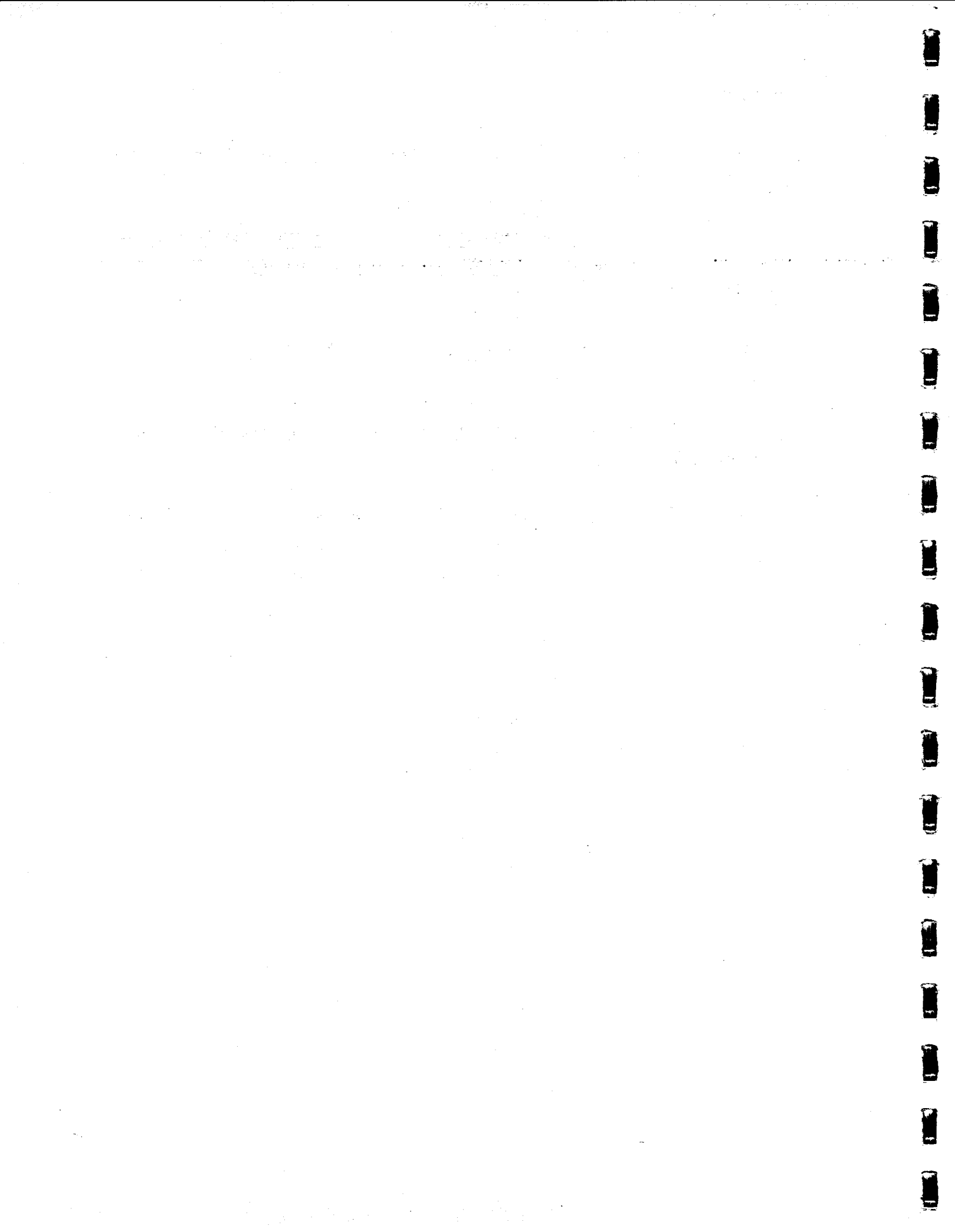

Measured Radioiodine Five Months After Accident (August 28, 1979)

Location	Percent of initial inventory
RCS	2-3
RB sump	12-19
RB atmosphere	0.002-0.003
RB surfaces	0.5-0.7
Aux. bldg. liquids	2-5
Total accounted for	
	17-28

S2 3644

Calculated Iodine Quantities

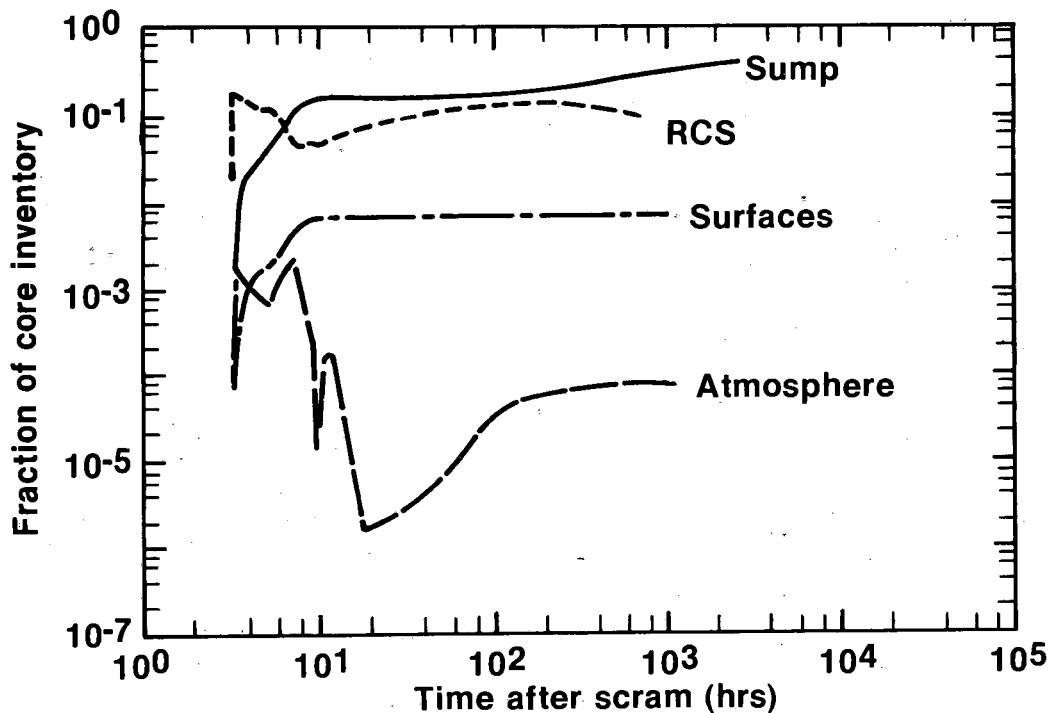

S2 4007

Measured Iodine Quantities

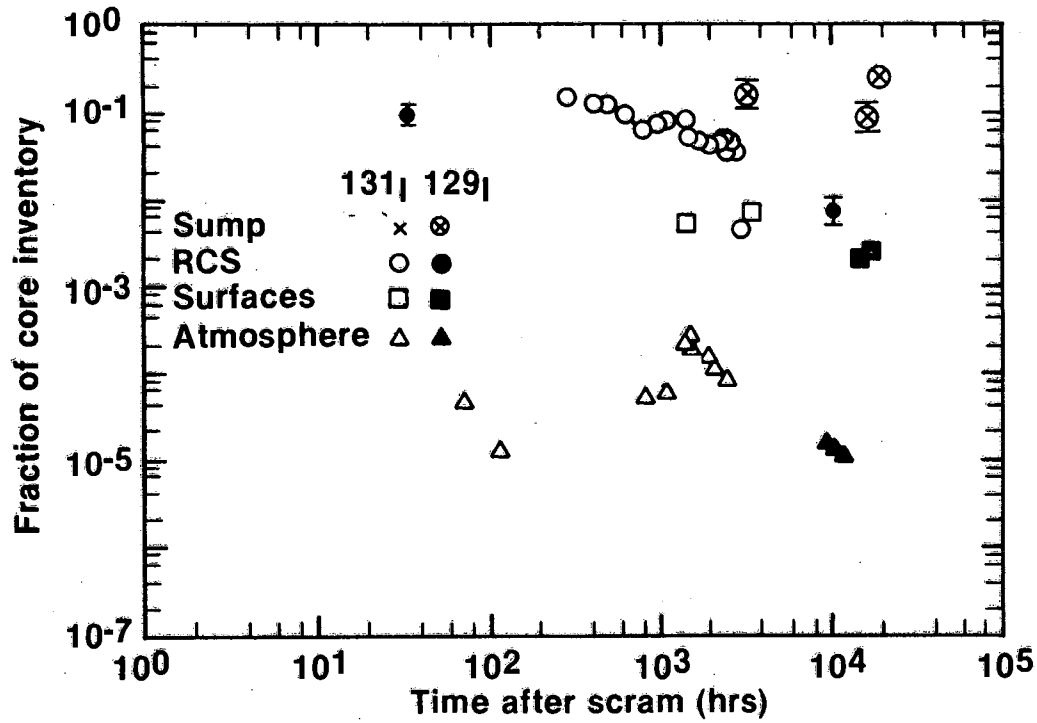

S2 4008

Calculated and Measured Iodine Quantities

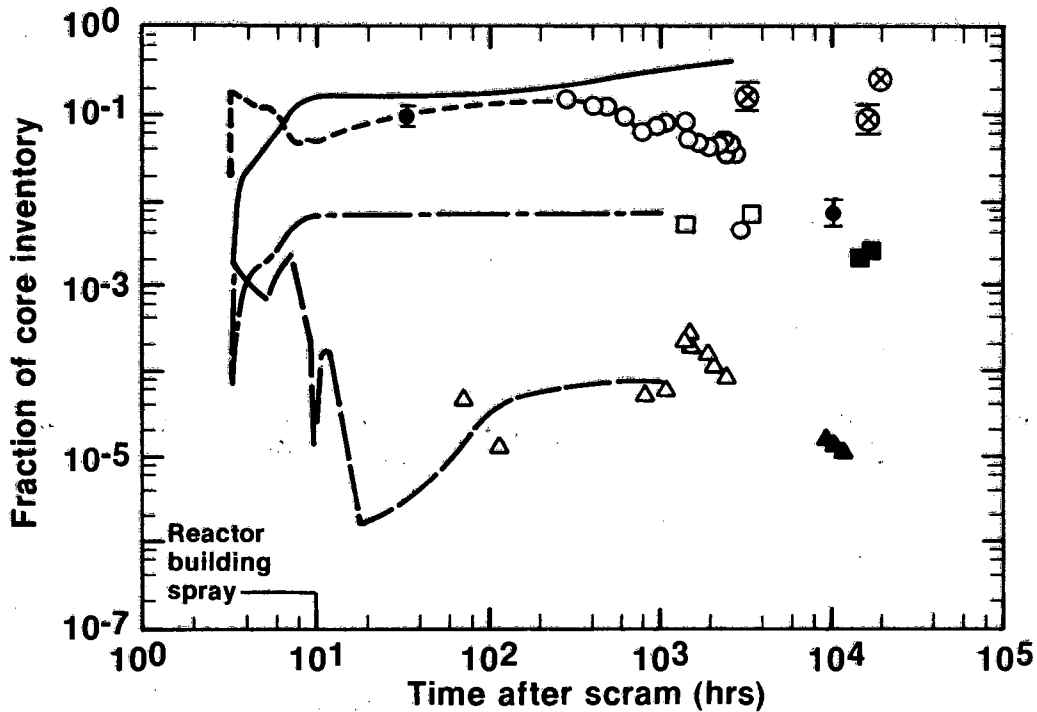

S2 3643

DOSE REDUCTION AND CONTAMINATION CONTROL IN THE
TMI-2 REACTOR BUILDING:
G. R. Eidam (EG&G Idaho, Inc.), D. W. Leigh (Bechtel National)

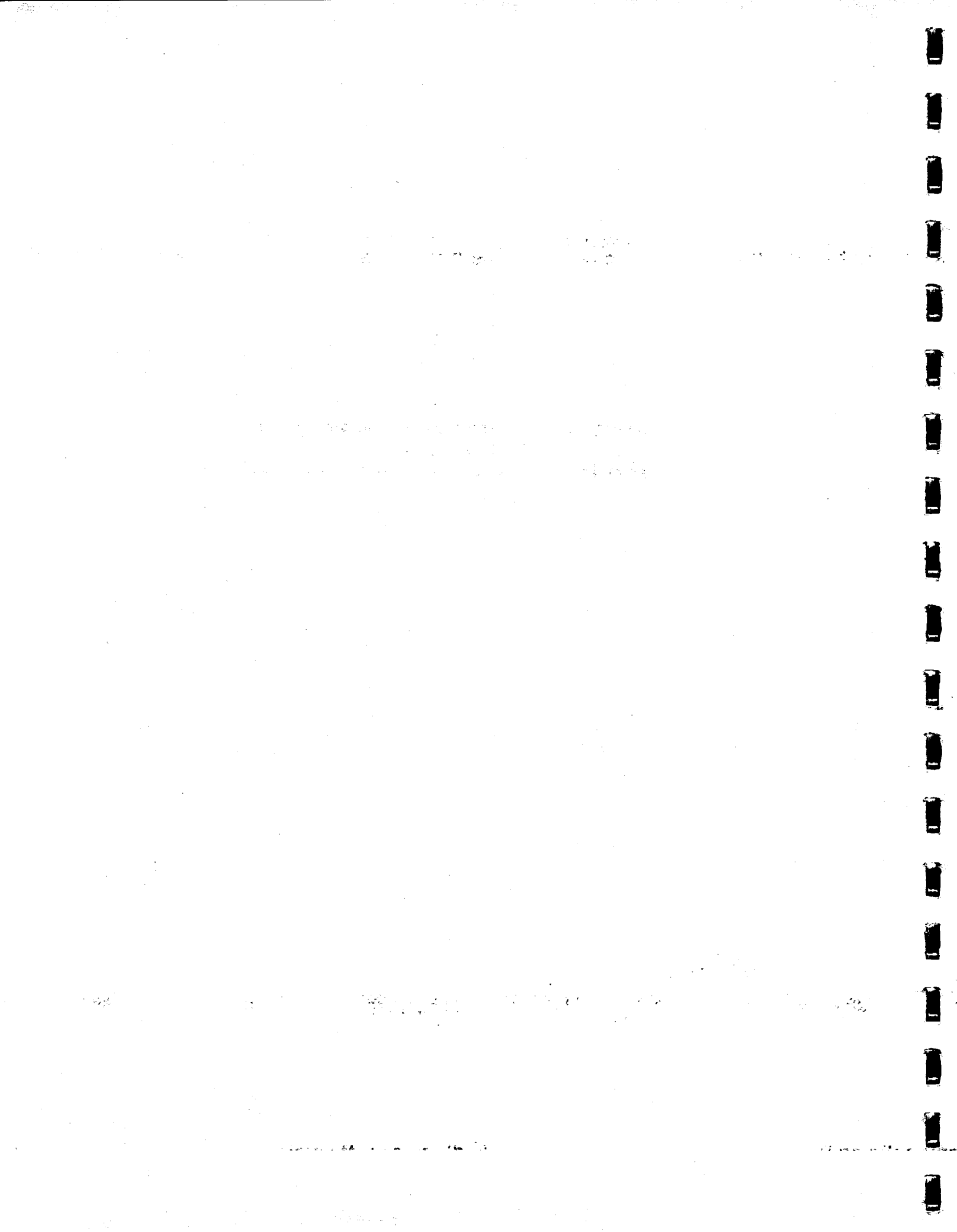

DOSE REDUCTION AND CONTAMINATION CONTROL
IN THE TMI-2 REACTOR BUILDING*

G. R. Eidam, EG&G Idaho, Inc.
D. W. Leigh, Bechtel National Corp.

After five months of preparation and many thousands of hours of work, the first gross decontamination experiment in the Three Mile Island Unit 2 reactor building was completed on March 24, 1982. During the three-week experiment, GPU Nuclear and its subcontractors used a pressurized-water spray technique called hydrolasing to decontaminate reactor building areas.

Hydrolasing used water at temperatures ranging from approximately 20 to 60°C and under pressures of from 13.8 to 41.4 MPa. Flowing at rates of $3.15 \times 10^{-4} \text{ m}^3/\text{s}$ to $1.57 \times 10^{-3} \text{ m}^3/\text{s}$, the water "washed" surface contamination from the walls and floors of the reactor building into drains and down to the building basement. From there, the water will be pumped through a contaminated-water processing system known as the Submerged Demineralizer System, which removes radioactive contaminants from the water. The water used in the experiment was itself a result of the accident, and had been decontaminated with another processing system called EPICOR II prior to its use during gross decontamination.

During the 11 reactor building entries required to complete the experiment, teams of two to three technicians each reduced contamination levels in several reactor building areas. These areas included the reactor building dome, the 454-t polar crane, the walkways on the top of the two

* Work supported by the U.S. Department of Energy, Assistant Secretary for Nuclear Energy, Office of Coordination and Special Projects, under DOE Contract No. DE-AC07-76ID01570.

D-rings, and the top of the reactor vessel missile shields. Also decontaminated were large tools, equipment, and floor surfaces on the operating deck, or 347-foot elevation, and overhead areas, walls, and floors on the entry level, or 305-foot elevation.

During the experiment, technicians tested other decontamination techniques. A mechanical floor scrubber was used on a section of the 347-foot elevation floor. Strippable coatings were used on sections of the 305-foot and 347-foot elevation floors. Before using any of the techniques, technicians flushed all surfaces with a low-pressure hot water spray.

Certain reactor building areas show significant reductions in both surface contamination and radiation levels, while other areas indicate only negligible differences. For example, decontamination significantly reduced surface contamination on the 305-foot elevation. However, the reductions were not as dramatic on the 347-foot elevation, where reactor building safety sprays activated during the accident and high humidity since the accident have already considerably reduced surface contamination.

To date over 70,000 manhours of planning, preparation, and pre- and postdecontamination reactor building work went into making the experiment possible. While support engineering functions such as equipment design, building modifications, and personnel training account for most of the manhours, about 110 manhours were spent actually conducting the experiment and 500 hours were devoted to such in-building work as equipment placement and pre- and postdecontamination data acquisition.

In-building predecontamination work included protecting various instruments from water spray, removing several instruments for research and development work, and installing the equipment necessary to perform the experiment. One special piece of equipment installed was a personnel and equipment lifting device called a Spider lift. The Spider lift transports people and equipment from the 305-foot elevation to the polar crane for decontamination work in that area.

In order to compare pre- and postdecontamination conditions and to measure the effectiveness of the experiment, samples and radiation readings of areas to be decontaminated were taken prior to actual decontamination work. In addition to general area radiation surveys, technicians conducted gamma spectrometer measurements of the reactor building air coolers and on the 305-foot and 347-foot elevations. Air samples were taken in the basement and on the other elevations, checking for iodine and particulates. Special thermoluminescent dosimeters (TLDs) designed for use at TMI provided general field surveys before the experiment. A surface sampling device obtained concrete and metal samples from reactor building floors, walls, and metal surfaces. All these samples will be analyzed and will be compared with similar samples taken after the decontamination experiment in order to assess the effectiveness of the work.

Postdecontamination survey and sampling work is well underway and documentation of the entire experiment has begun. The final report, to be published in the fall of 1982, will compare pre- and postdecontamination survey and sample results, will evaluate how effective or ineffective the different decontamination techniques were in reducing radiation levels, and will provide the nuclear industry with data needed to assist them in any future decontamination activities and eventual plant decommissioning work.

of his anti-Nazi sentiments. He was a member of the
tribunal which had sentenced the Kaiser to life imprisonment
in 1918. He had also been a member of the Reichstag
in 1920. He was a member of the Reichstag in 1920.
He was a member of the Reichstag in 1920.

He was a member of the Reichstag in 1920.
He was a member of the Reichstag in 1920.
He was a member of the Reichstag in 1920.
He was a member of the Reichstag in 1920.

He was a member of the Reichstag in 1920.
He was a member of the Reichstag in 1920.
He was a member of the Reichstag in 1920.
He was a member of the Reichstag in 1920.

He was a member of the Reichstag in 1920.
He was a member of the Reichstag in 1920.
He was a member of the Reichstag in 1920.
He was a member of the Reichstag in 1920.

He was a member of the Reichstag in 1920.
He was a member of the Reichstag in 1920.
He was a member of the Reichstag in 1920.
He was a member of the Reichstag in 1920.

He was a member of the Reichstag in 1920.
He was a member of the Reichstag in 1920.
He was a member of the Reichstag in 1920.
He was a member of the Reichstag in 1920.

He was a member of the Reichstag in 1920.
He was a member of the Reichstag in 1920.
He was a member of the Reichstag in 1920.
He was a member of the Reichstag in 1920.



TMI-2

Gross Decontamination Experiment

G. R. Eidam
Technical Coordinator

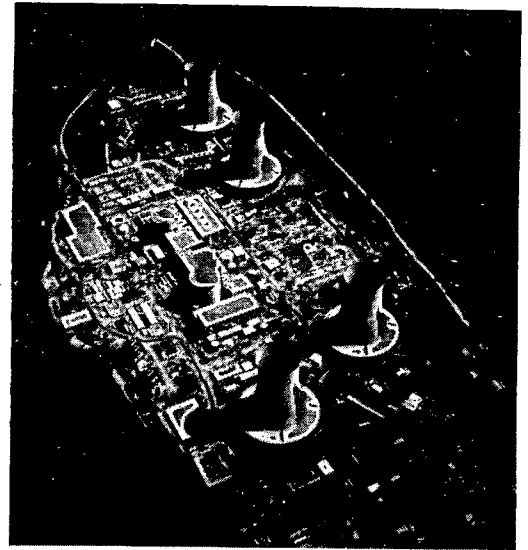

S2 10 688

Gross Decontamination Objectives

- Evaluate methods and equipment
 - Safety
 - Efficiency
 - Effectiveness
- Reduce contamination on selected surfaces

S2 10 674

Areas Decontaminated

- Reactor building dome
- Polar crane
- Top of D-rings
- Refueling canal
- 347-foot operating level
- 305-foot entry level

S2 10 675

8-11-01 02

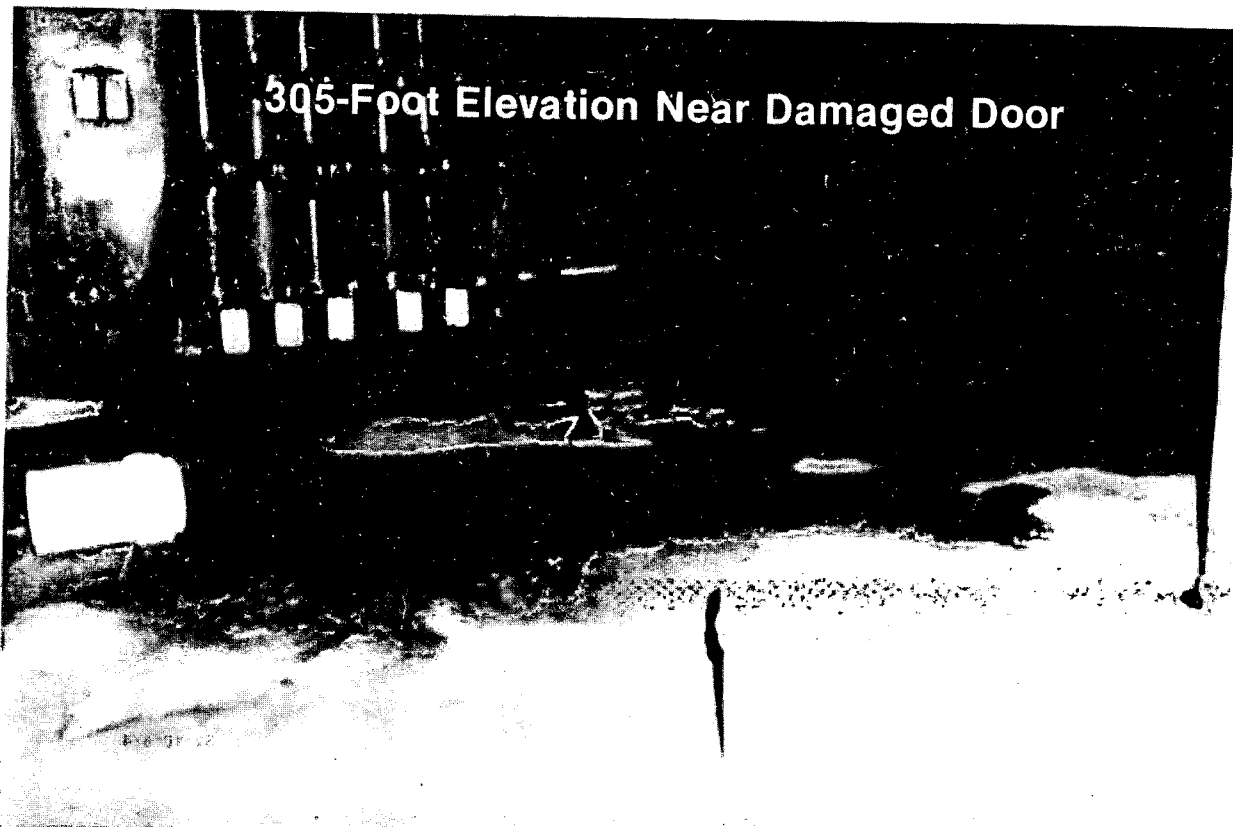

305-Foot Elevation Floor

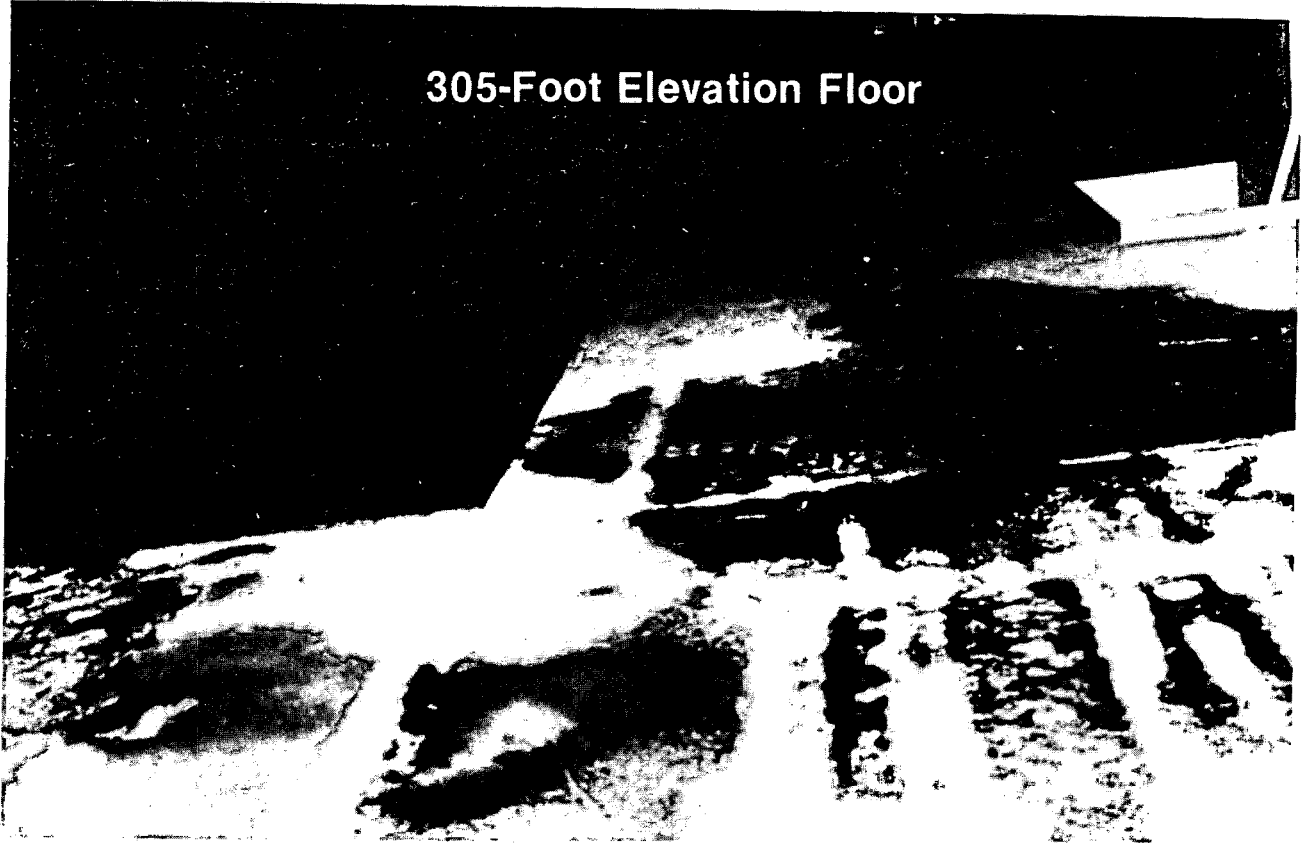

**Moved Deck Plate
305-Foot Elevation**

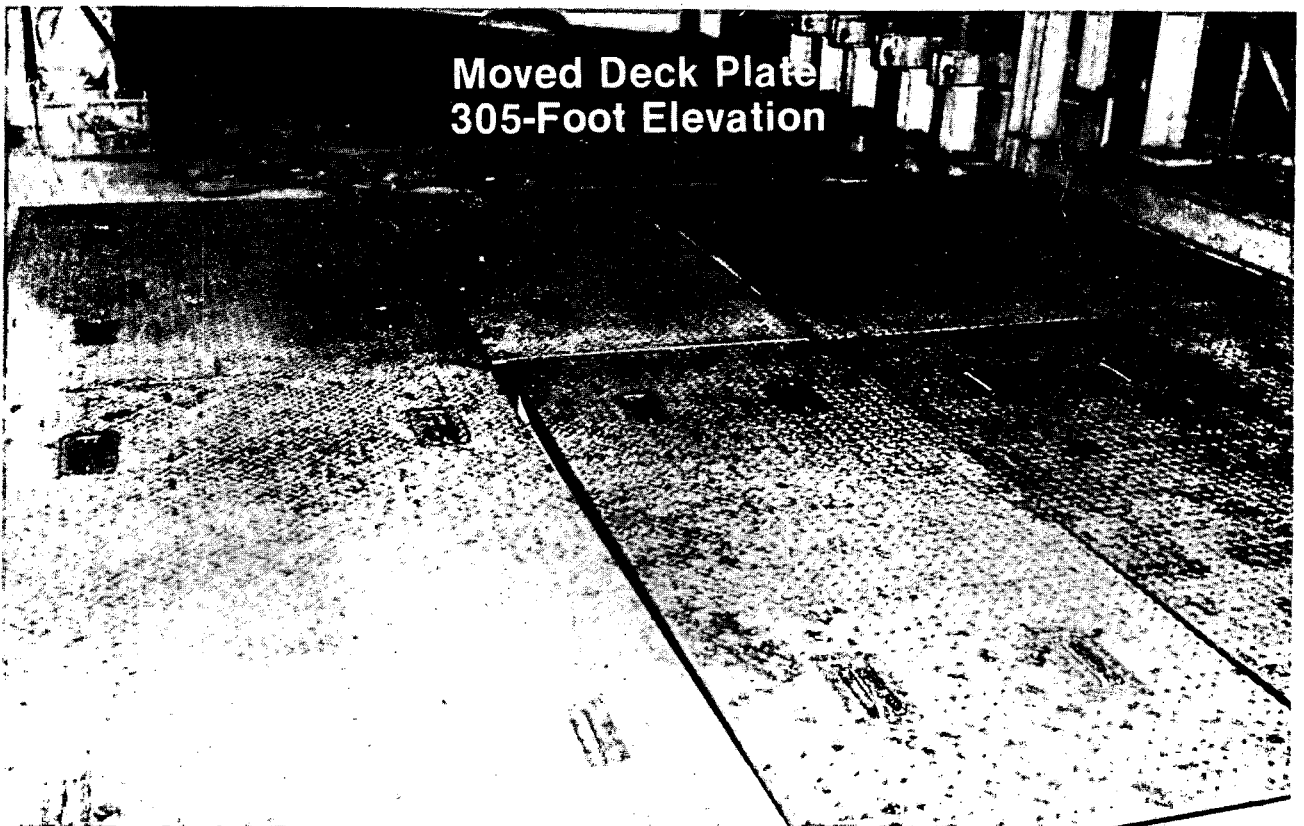

347-Foot Elevation

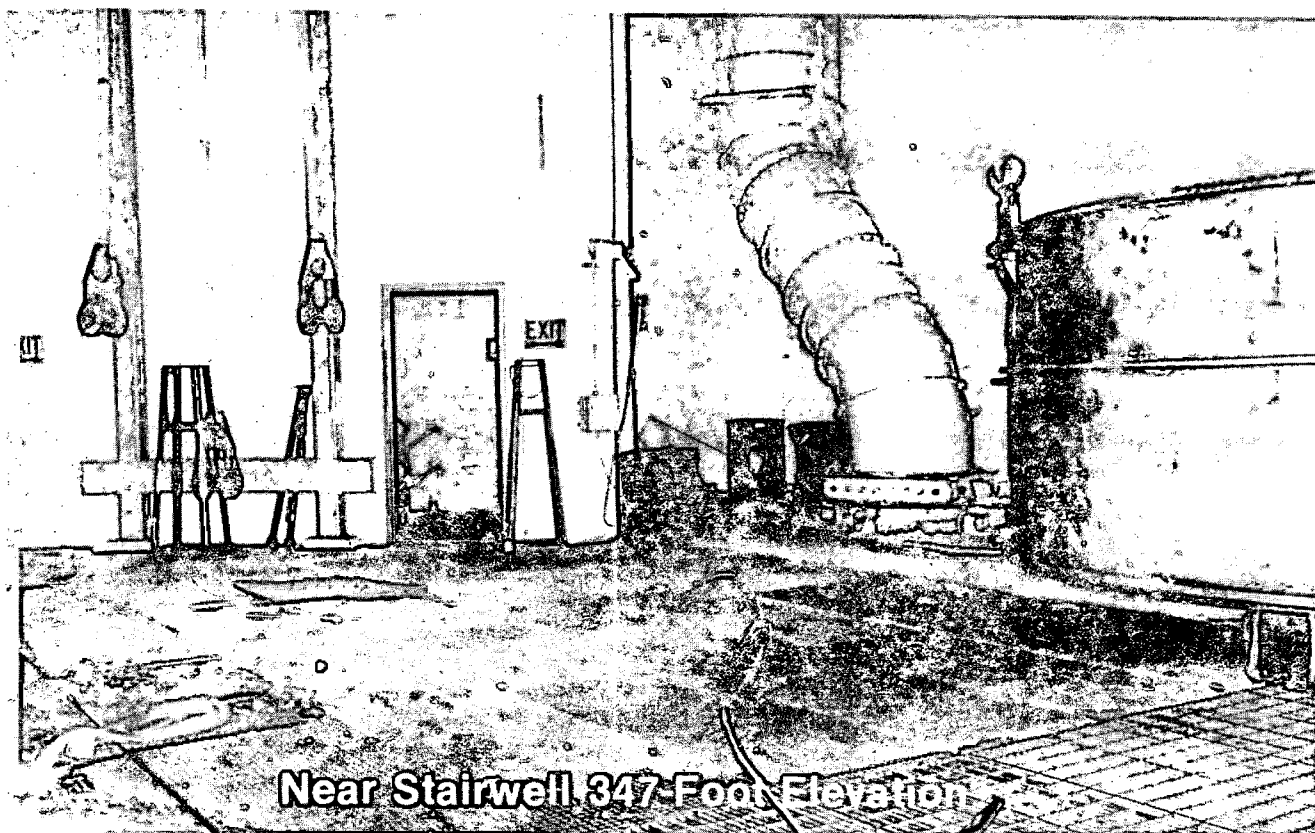
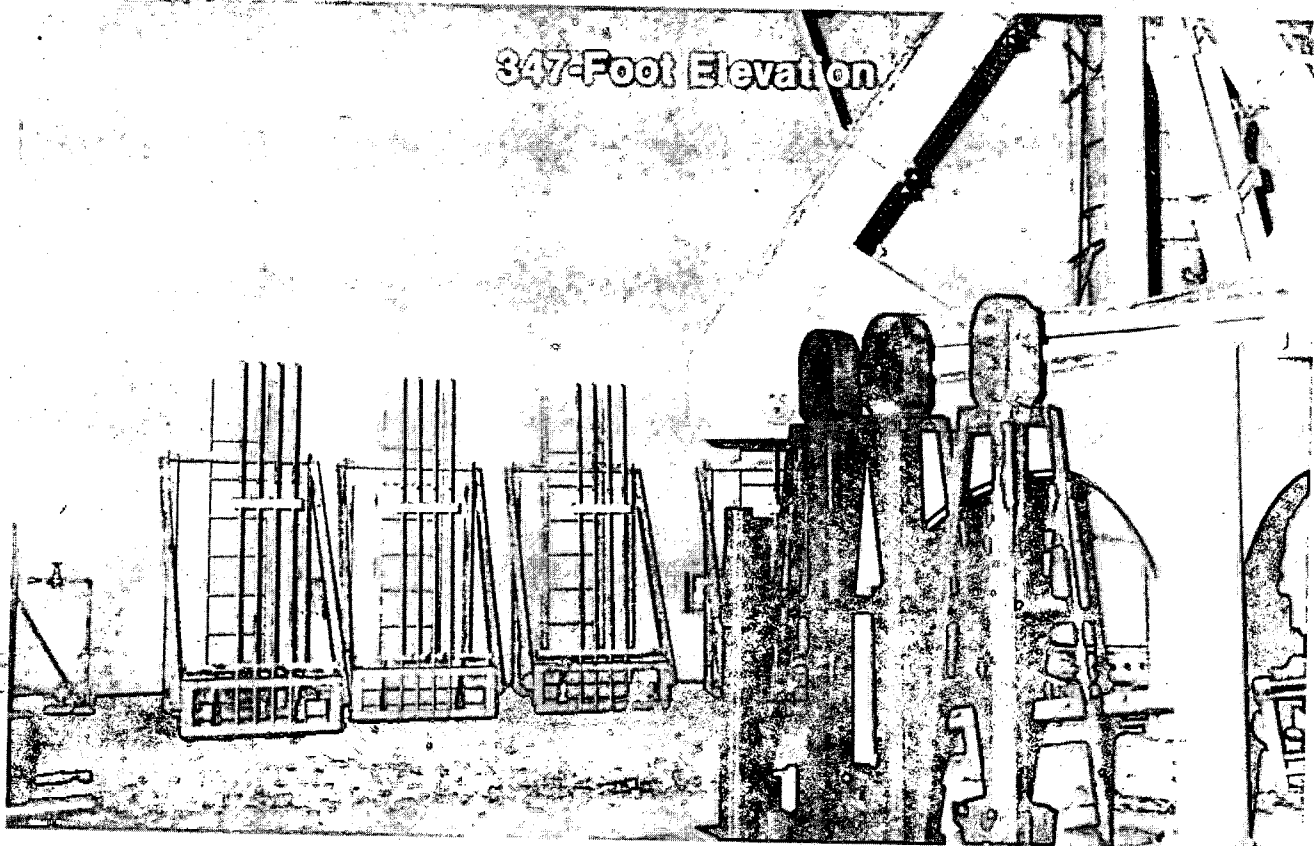

Near Stairwell 347-Foot Elevation

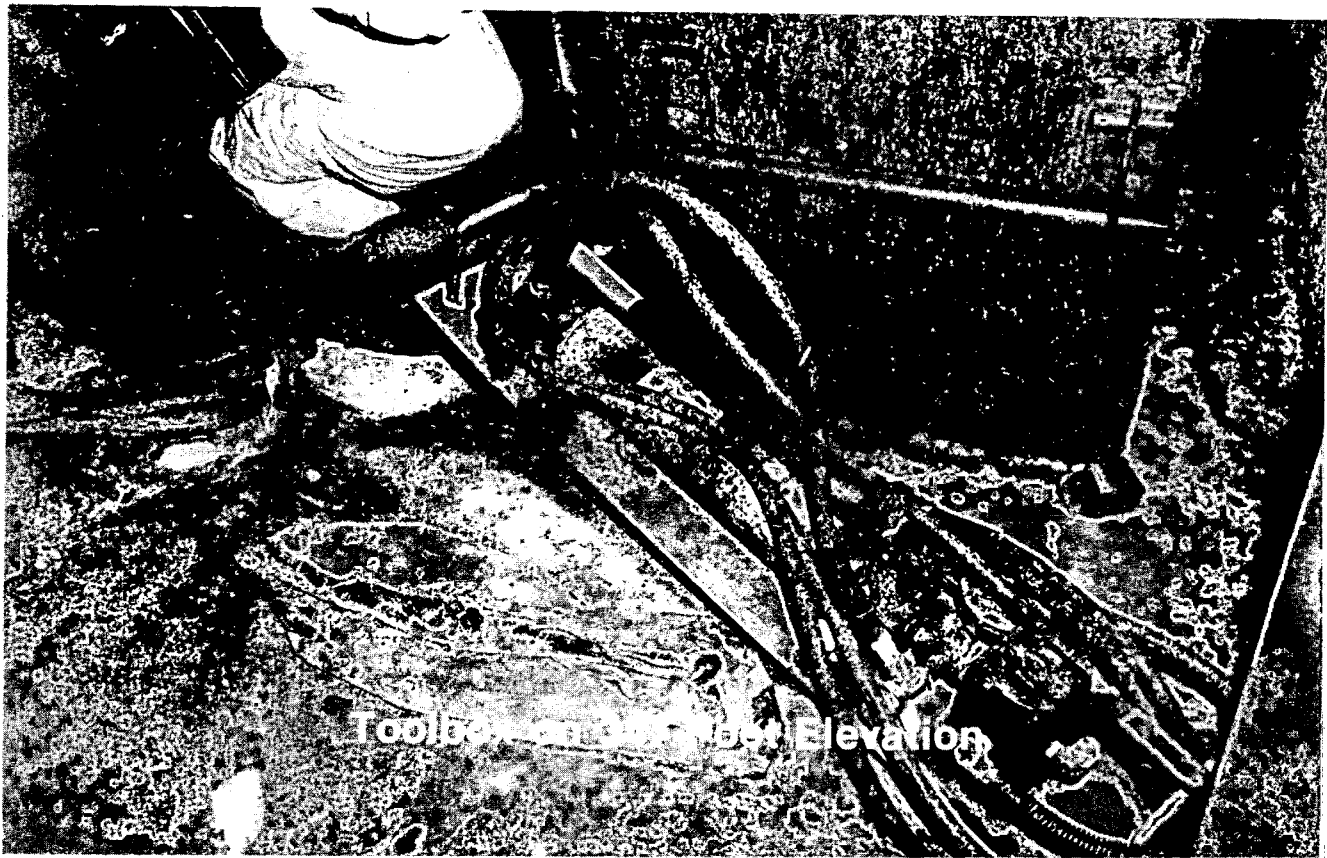

Decontamination Techniques

- High pressure flush (2000-6000 psig)
- Low pressure flush (60-2000 psig)
- Spin jet (2000-6000 psig)
- Strippable coating (350 ft²)
- Mechanical scrubbing (150 ft²)

Hydrolasing Equipment

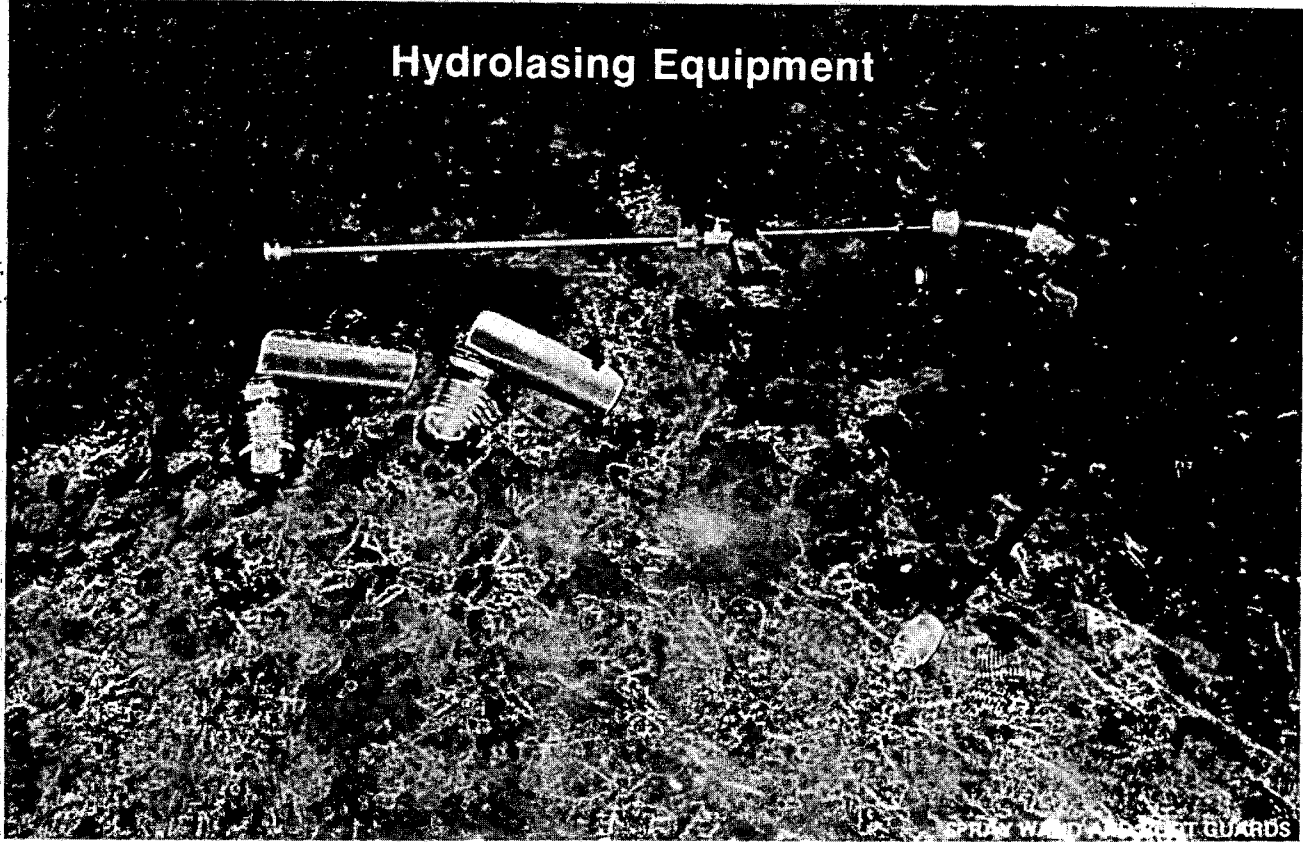

Spinjets for Floor Decontamination



Strippable Coating Test on 305-foot Elevation

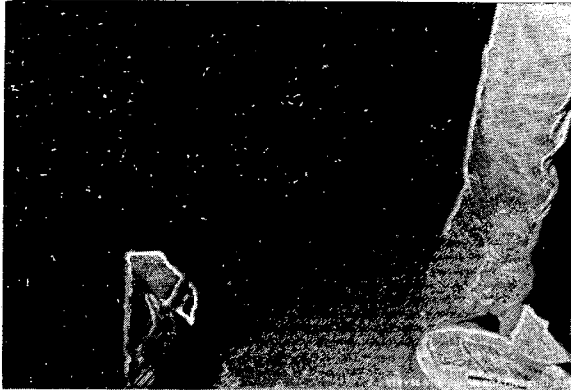

Before



During

Support Work

- **Equipment protection**
- **Penetration modification**
- **Hot water and electrical supply**
- **Mockup facilities**
- **Personnel and equipment lift**
- **Area cleanup and trash removal**

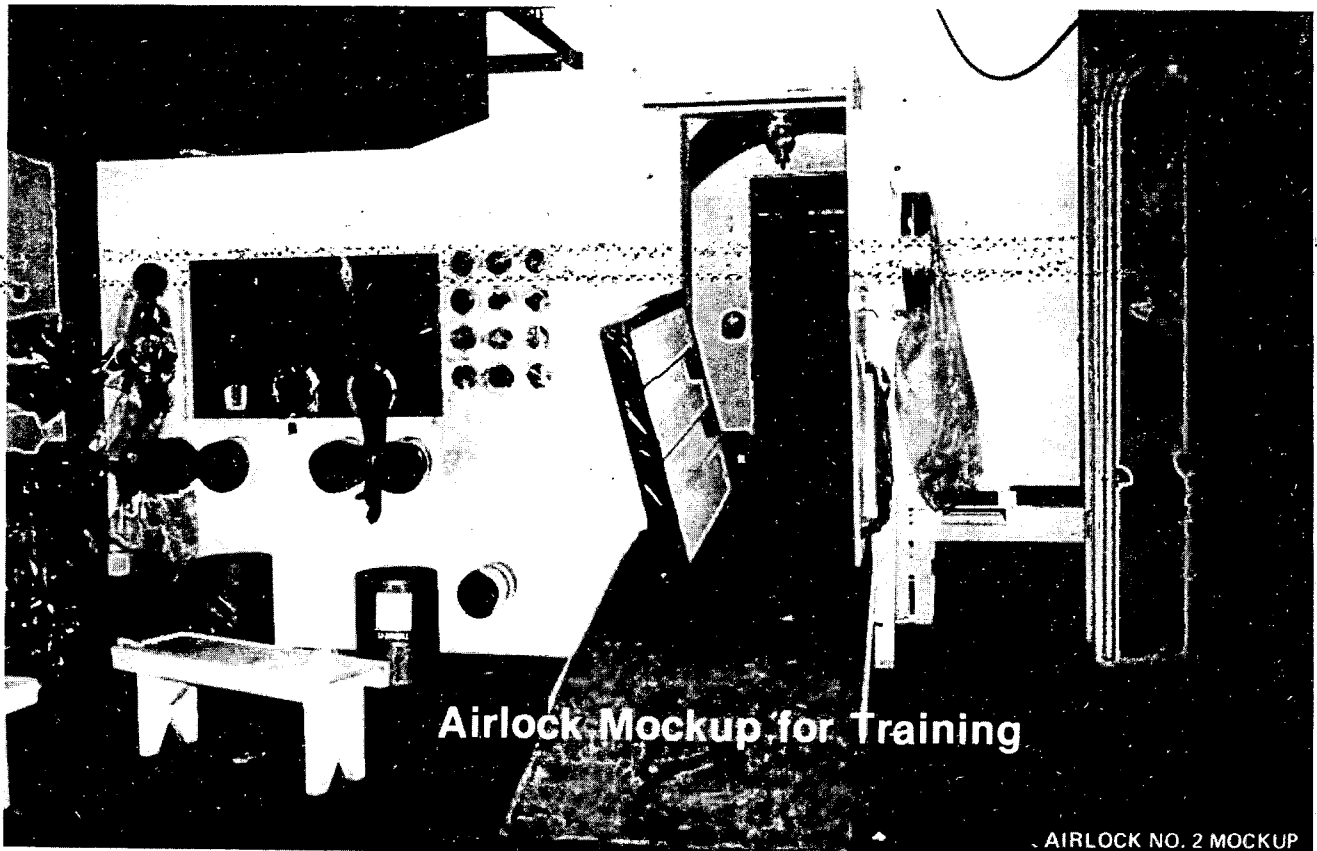

Reduction Factors

<u>Location</u>	<u>RF (Samples)</u>	<u>RF (Swipes)</u>
305-ft. el.	24.7	25.0
347-ft. el.	24.8	25.0
Top D-rings	2.0	4.0
Refueling canal	Not taken	2.0

Average Reduction in Radiation Fields

	<u>Average mr/hr</u>	<u>Range mr/hr</u>
305-ft. el.	50	0-110
347-ft. el.	17	3-50
Top of D-rings	30	10-55
Canal	60	20-100

S2 10 689

Current Average Radiation Fields

	<u>Current Average mr/hr</u>	<u>Range mr/hr</u>
305-ft. el.	200	120-400
347-ft. el.	100	65-140
Top of D-rings	120	100-180
Canal	80	30-110

S2 10 679

Exposure Rate Reduced

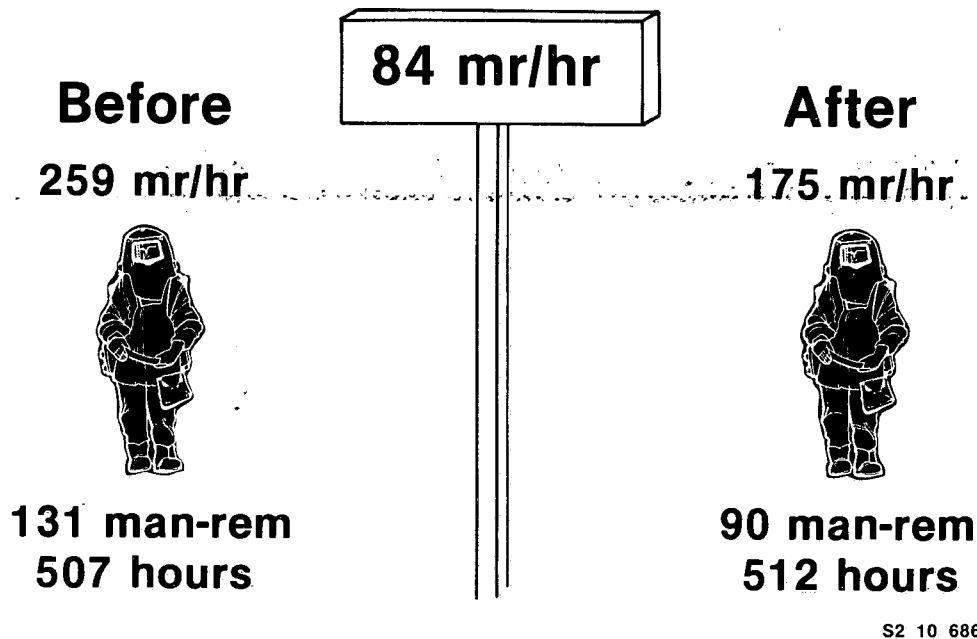

S2 10 686

Man-Hour and Man-Rem Expenditures

	<u>Hours</u>	<u>Rem</u>
Support	163	36
Surveys	126	29
Decon.	117	26
Data acquisition	47	13
Misc.	15	5
	<hr/>	<hr/>
	468	109
	Man-hours	Man-rem

S2 10 678

Ratios for In-Containment Work

Man-hours outside to man-hours in-containment

Radiological controls 11 to 1

Engineering 53 to 1

Manual labor 74 to 1



**138 outside man-hours to
1 in-containment man-hour**

S2 10 682

Benefits for Future Work

- Standard procedures established
 - Decontamination
 - Building entries
- Equipment purchased and installed
- Mockup facilities built
- Training program established
- Decontamination team established

S2 10 685

Reduced Ratios Expected for Future Work

Man-hours outside to man-hours in-containment

Radiological controls	10 to 1
Engineering	10 to 1
Manual labor	20 to 1

**About 40 outside man-hours
to 1 in-containment man-hour**

S2 10 684

SURFACE DEPOSITION MEASUREMENTS OF
TMI-2 GROSS DECONTAMINATION EXPERIMENT:
C. V. McIsaac, D. C. Hetzer (EG&G Idaho, Inc.)

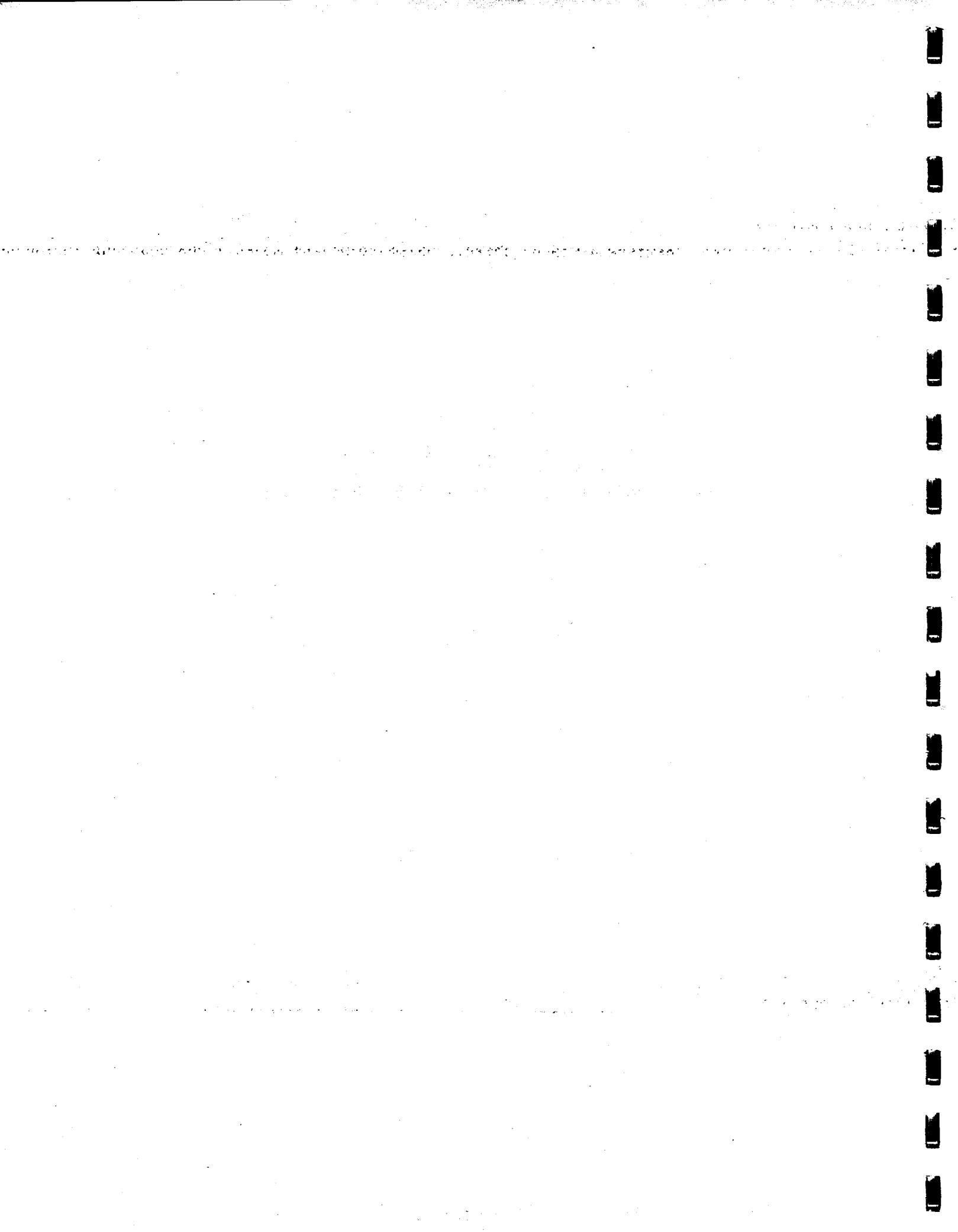

SURFACE DEPOSITION MEASUREMENTS OF THE
TMI-2 GROSS DECONTAMINATION EXPERIMENT*

C. V. McIsaac, EG&G Idaho, Inc.

D. C. Hetzer, EG&G Idaho, Inc.

In order to measure the effectiveness of the gross decontamination experiment (principally a water spray technique) performed in the TMI-2 reactor building, the Technical Information and Examination Program's Radiation and Environment personnel made surface activity measurements before and after the experiment. In conjunction with surface sampling, thermoluminescent dosimeter (TLD) and gamma spectrometry measurements were also performed to distinguish between radiation fields and contamination.

The surface sampler used to collect samples from external surfaces within the reactor building is a milling tool having four major components: a 1.27-cm constant-speed drill; a drill support assembly that allows setting sample penetration depth; filter cartridges for intake air purification and sample collection; and an air pump that forces air across the surface being sampled and through the sample filter cartridge. An oval foam rubber gasket on the bottom surface of the sampler seals the airflow pathway, and a port near the drill bit allows for easy manual change-out of the sample filter cartridge.

To minimize cross-contamination between samples a new bit was installed in the sampler prior to collection of each sample. A carbide bit was employed for milling concrete and cinder block surfaces and a hardened steel bit was used for milling metal surfaces. The sample collection procedure used for horizontal surfaces included an initial vacuum of the

* Work supported by U.S. Department of Energy, Assistant Secretary for Nuclear Energy, Office of Coordination and Special Projects, under DOE Contract No. DE-AC07-76ID01570.

surface without drill operation to remove loose particulates. While the sampler remained stationary a new sample filter cartridge was installed following the vacuuming and prior to surface milling.

The sample filter cartridges were made using 5.08 cm diameter PVC couplers and caps and 1.59 cm inside diameter plastic tube. A Whatman 16 μm paper filter was mounted in each cartridge by means of a stainless steel screen, an O-ring, and snap rings.

After receipt at the Idaho National Engineering Laboratory (INEL), each sample cartridge was opened and the loose contents and filter were transferred to a preweighed Petri dish. Visual observations of the sample were recorded. The Petri dish was then reweighed to determine sample-plus-filter mass. The internals of the cartridge were washed with 50 ml 1 N HCl spiked with 3.3 mg Na_2SO_3 and 3.3 mg KI, followed by 50 ml deionized water rinse. The contents of the Petri dish were then transferred to the same bottle and the sample was analyzed by gamma spectrometry.

Prior to decontamination, floors on both elevations were considerably more contaminated than walls, as might be expected. The ratio of the average ^{137}Cs surface activities of the concrete floor to that of the wall is about 35 to 1 for the 347-foot elevation and about 50 to 1 for the 305-foot elevation. These values drop to 5 to 1 and 17 to 1 respectively after decontamination. The average ^{137}Cs surface activity on both floors is about the same before decontamination-- $1.11 \times 10^5 \text{ Bq/cm}^2$ and $1.85 \times 10^5 \text{ Bq/cm}^2$ on the 347- and 305-foot elevation floors respectively. Following decontamination the average concentrations are reduced to $1.48 \times 10^4 \text{ Bq/cm}^2$ and $3.70 \times 10^4 \text{ Bq/cm}^2$ respectively. The averages of the measured ^{137}Cs surface activities are given in Table 1 for horizontal concrete surfaces. The vacuum sample surface activity was calculated assuming a 39.03 cm^2 collection area and an even distribution of the particulates over that area, while the milled sample surface activity was calculated assuming a 1.27 cm^2 sample core area. All surface activities were calculated assuming a sampler activity collection efficiency of 100%.

Samples were collected at multiple depths at each of six sample locations before decontamination operations commenced and at seven locations following completion of decontamination. Sampling was done at depths from 2×10^{-2} to 3×10^{-1} cm in the same vicinity. The results at this time are inconclusive given that the measurement of the sampler collection efficiency as a function of depth has not yet been completed.

Using the measured pre- and postdecontamination surface activities, decontamination factors (DFs) were calculated. The decontamination factors given are the ratios of surface activity before decontamination to surface activity after decontamination. The mean ^{137}Cs DFs achieved on the 347- and 305-foot elevation floors were about 14 and 29 respectively for "fixed" contamination and about 53 and 140 for "loose" particulate contamination. On average, vertical concrete surfaces on the 347-foot elevation exhibited about a 30% increase in ^{137}Cs contamination at the time of measurement as a result of decontamination operations, and three of four D-ring locations on the 305-foot elevation also showed increases in ^{137}Cs surface activity.

TABLE 1. MEAN ^{137}Cs SURFACE ACTIVITY CONCENTRATIONS ON HORIZONTAL CONCRETE SURFACES AS OF MARCH 1982 (Bq/cm^2)

Elevation	Vacuumed		Milled	
	Predecon	Postdecon	Predecon	Postdecon
367 ft-4 in.	1.11E+3	7.40E+2	7.40E+4	3.33E+4
347 ft-6 in.	2.22E+3	3.70E+1	1.11E+5	1.48E+4
305 ft-0 in.	2.96E+3	7.40E+1	1.85E+5	3.70E+4

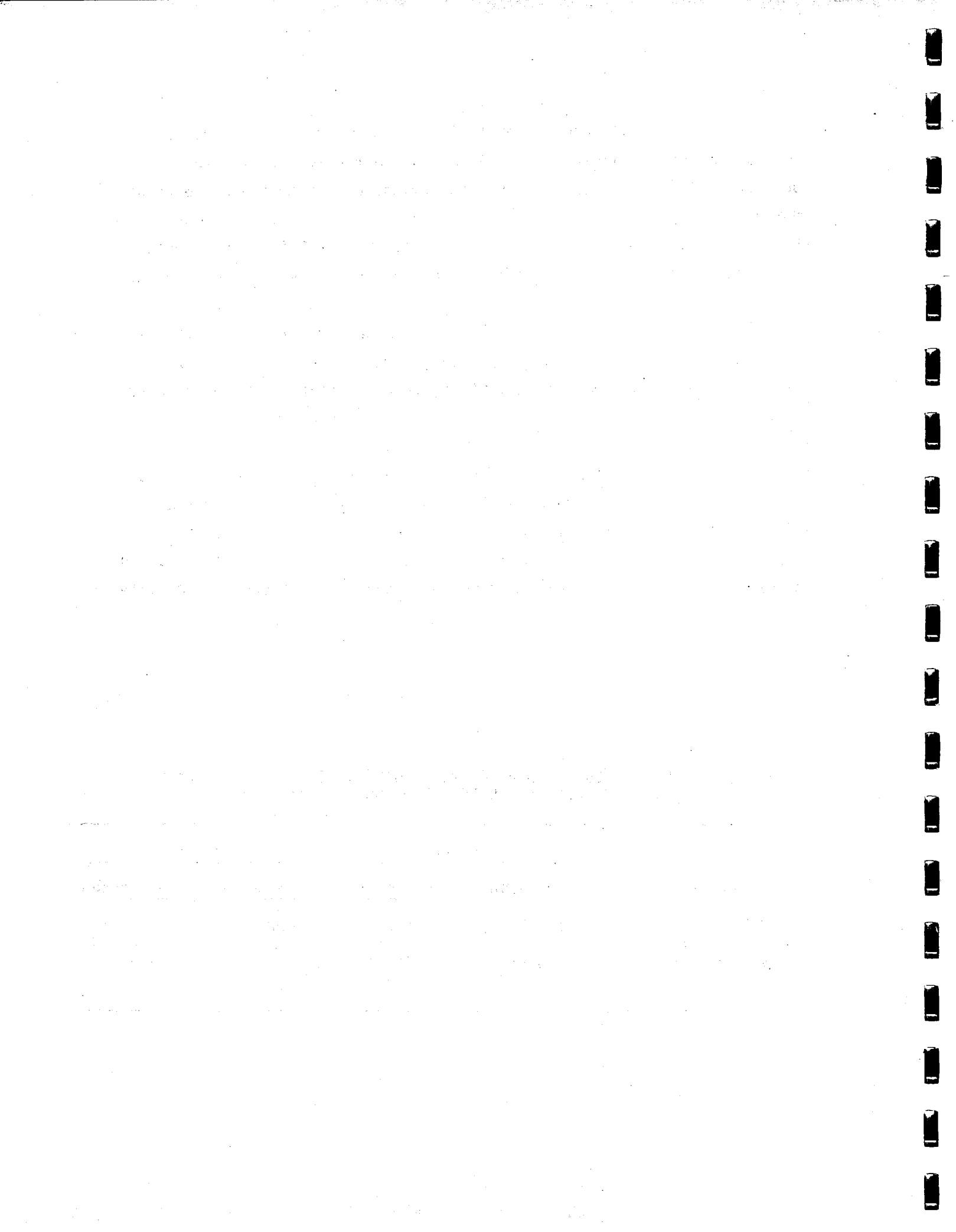

EVALUATION OF NONCHEMICAL DECONTAMINATION FOR
TMI-2 RCS APPLICATION:

H. R. Gardner (Quadrex, Richland),
R. P. Allen (Pacific Northwest Laboratory),
L. M. Polentz (Quadrex, Richland),
W. E. Skiens (Pacific Northwest Laboratory),
G. A. Wolf (Quadrex, Richland),
L. E. Anderson (Electric Power Research Institute)

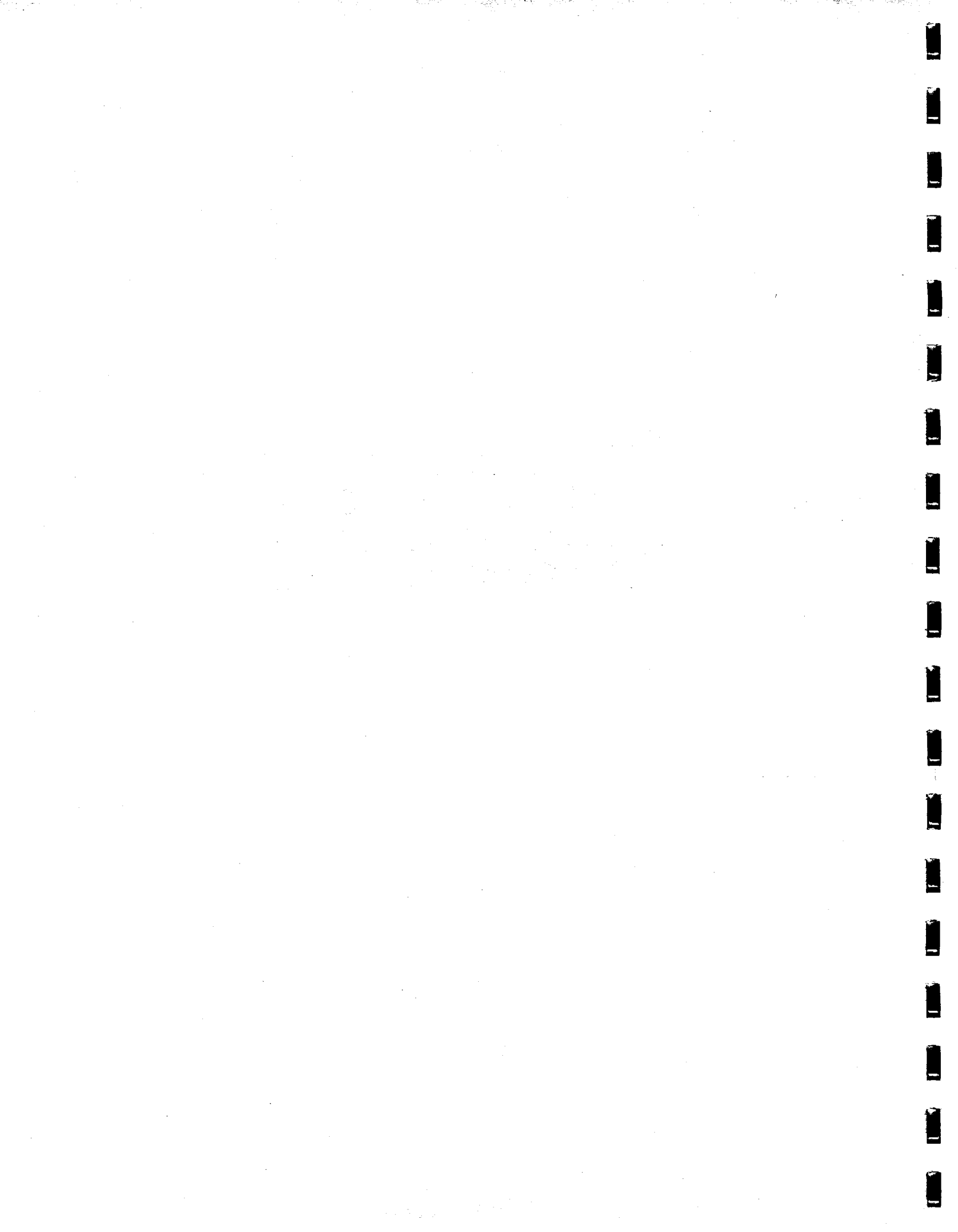

EVALUATION OF NONCHEMICAL DECONTAMINATION TECHNIQUES
FOR TMI-2 RCS APPLICATION

H. R. Gardner, R. P. Allen, L. M. Polentz,
W. E. Skiens, G. A. Wolf, L. E. Anderson

A wide variety of techniques which can be utilized for the decontamination of radioactively contaminated surfaces are available to meet the needs of nuclear facilities. The purpose of this work, sponsored by the Electric Power Research Institute, is to describe, characterize, and evaluate techniques that appear to have potential for decontamination and/or the removal of fuel debris and corrosion products from the TMI-2 RCS (reactor coolant system) and its components. The techniques selected for evaluation include those with only in-place capability, those with only off-system capability, and those with both in-place and off-system capability. Excluded from consideration are the traditional or common chemical decontamination techniques. The techniques treated are: Mechanical Methods; High-Pressure Water (<20,000 psig); Ultrahigh-Pressure Water (>20,000 psig); Abrasive Cleaning (including Pumped Abrasive Slurries); Vibratory Finishing; Ultrasonics; High-Pressure FREON Cleaning; Electropolishing; Alternative Electrolyte Techniques; Steam/Hot Water Cleaning and Two-Phase Mixtures; Decontamination Foams, Gels, and Pastes; Electrochemically-Activated Solutions; Molten Salt Methods; and Thermal Erosion.

The information developed for each technique includes: Theory of Operation; Methods of Application; Accessibility Requirements; Remote Operation Capability; State of Development; Previous Applications; Process Effectiveness; Corrosion; Material Removal; Radiological and Industrial Safety; Economics; Post-Decontamination Cleanup; Need for Post Decontamination Surface Treatment; Waste Generation, Storage, Processing, and Disposal Considerations; Potential for Redistribution of Contamination; Advantages; and Disadvantages.

The techniques are evaluated for groups of TMI-2 RCS components selected on the basis of commonality of decontamination approach. The groupings of components derived are: Heat Exchanger Tubing; Pipe One to 20 In. I.D.; Tanks, Filter Housings, and Pipe 28 In. I.D. and Larger; Tanks with Internal Hardware; and Valves and Pumps.

The applicability of the techniques is evaluated against a set of criteria, and a system of grading and weighting factors using a matrix approach for technique comparison. Two categories of criteria were established: cleaning/decontamination effectiveness, and impact on potential for use of a technique. The effectiveness criteria include: Loose Debris Removal, Adherent Particle Removal, Particle Removal From Crevices, Production Rate, Remote Operation, and Degree of Development.

For impact on potential for use of a technique, the following criteria were considered: Radiological Safety, Waste Generation, Need for Disassembly, Accessibility, Size of Item, Capital Cost, Operating Cost, Requalification, Corrosiveness, and Industrial Safety. Grading and weighting factors vary with each criterion depending on its perceived importance.

Based on the information developed in this study, the most useful in-place decontamination techniques for application to the TMI-2 RCS include: Mechanical Methods (Water Propelled Devices, Plastic Plugs, Scrapers, Brushes, and Hones), High-Pressure Water, Ultrahigh-Pressure Water, and Pumped Abrasive Slurries. For off-system decontamination, the most useful techniques include: Vibratory Finishing, High-Pressure Water, Ultrahigh-Pressure Water, Mechanical Brushes and Hones, and FREON Cleaning. Less developed techniques with good potential for effective, low impact decontamination include: Dry Ice Blasting, Ice Blasting, and Xenon-Quartz Lamp Surface Heating.

The information developed can be used to aid in selection of the most useful technique(s) for a given TMI-2 RCS application, and as a starting point for the development of plans and procedures for decontamination projects.

EVALUATION OF NONCHEMICAL DECONTAMINATION TECHNIQUES FOR USE ON REACTOR COOLANT SYSTEMS

H. R. GARDNER
R. P. ALLEN*
L. M. POLENTZ
W. E. SKIENS*
G. A. WOLF
L. E. ANDERSON**

*EMPLOYEE OF BATTELLE NORTHWEST
**EPRI PROJECT MANAGER

WORK SPONSORED BY ELECTRIC POWER RESEARCH INSTITUTE

NONCHEMICAL DECONTAMINATION

TASKS

- DESCRIBE IN-PLACE AND OFF-SYSTEM TECHNIQUES
- RECOMMENDATIONS FOR APPLICATION OF TECHNIQUES
- RECOMMENDATIONS FOR TECHNIQUE DEVELOPMENT/
DEMONSTRATION

OBJECTIVE

**DESCRIBE AND CHARACTERIZE POTENTIALLY APPLICABLE
NONCHEMICAL DECONTAMINATION TECHNIQUES**

IN-PLACE TECHNIQUES EVALUATED

- **IN-SITU ELECTROPOLISHING**
- **ALTERNATIVE ELECTROLYTE TECHNIQUES**
- **ABRASIVE CLEANING**
- **HIGH-PRESSURE WATER (<20,000 PSI)**
- **ULTRA HIGH-PRESSURE WATER (>20,000 PSI)**
- **STEAM CLEANING AND TWO PHASE MIXTURES**
- **DRY ICE BLASTING**
- **FREON CLEANING**

IN-PLACE TECHNIQUES EVALUATED

(Continued)

- **ELECTROCHEMICALLY-ACTIVATED SOLUTIONS**
- **DECONTAMINATION FOAMS, GELS AND PASTES**
- **MOLTEN SALT METHODS**
- **REFLUX DECONTAMINATION**
- **THERMAL EROSION**
- **REMOTE MECHANICAL METHODS**
- **STRIPPABLE DECONTAMINATION COATINGS**

OFF-SYSTEM TECHNIQUES EVALUATED

- **ULTRASONICS**
- **IMMERSION ELECTROPOLISHING**
- **HIGH PRESSURE WATER**
- **ABRASIVE CLEANING**
- **VIBRATORY FINISHING**
- **MECHANICAL TECHNIQUES**
- **HIGH PRESSURE FREON**

INFORMATION EVALUATED FOR EACH TECHNIQUE

TECHNICAL DESCRIPTION

- THEORY
- APPLICATION METHODS
- ACCESSIBILITY/SIZE CONSTRAINTS
- REMOTE OPERATION

INDUSTRIAL APPLICATION

- STATE OF DEVELOPMENT
- PREVIOUS APPLICATIONS

INFORMATION EVALUATED FOR EACH TECHNIQUE

(Continued)

CHARACTERIZATION FOR NUCLEAR APPLICATION

- PROCESS EFFECTIVENESS
- CORROSION
- MATERIAL REMOVAL
- RADIOLOGICAL/INDUSTRIAL SAFETY
- ECONOMICS
- POST-DECONTAMINATION CLEANUP
- NEED FOR POST-DECONTAMINATION SURFACE TREATMENT
- WASTE GENERATION
- REDISTRIBUTION OF CONTAMINATION

EVALUATION

- ADVANTAGES
- DISADVANTAGES

OBJECTIVE

COMPARISON OF NONCHEMICAL DECONTAMINATION TECHNIQUES AND RECOMMENDATIONS FOR APPLICATION TO RCS COMPONENTS

IN-PLACE DECONTAMINATION COMPARISON CRITERIA AND WEIGHTING, AND GRADING FACTORS FOR PIPE ONE TO 20 IN. I.D.

GRADING FACTORS	WEIGHTING FACTORS	DECONTAMINATION EFFECTIVENESS
2,0,-1	4	• LOOSE DEBRIS REMOVAL—COMPLETE, MODERATE, NONE
2,0,-1	2	• ADHERENT PARTICLE REMOVAL—COMPLETE, MODERATE, NONE
2,0,-1	2	• PARTICLE REMOVAL FROM CREVICES—COMPLETE, MODERATE, NONE
1,0	4	• EFFECT OF INTERNAL COMPONENTS—NONE, ADVERSE
1,0,-1	2	• PRODUCTION RATE—HIGH, INTERMEDIATE, LOW
1,0,-1	2	• REMOTE OPERATION—EXTENSIVE, SEMI, HANDS-ON
1,0,-1	2	• DEGREE OF DEVELOPMENT—COMMERCIAL DECON, LIMITED DEMO, LAB TEST/CONCEPT

IN-PLACE DECONTAMINATION COMPARISON CRITERIA AND WEIGHTING, AND GRADING FACTORS FOR PIPE ONE TO 20 IN. I.D.

(Continued)

GRADING FACTORS	WEIGHTING FACTORS	IMPACTS AND CONSTRAINTS
1,0,-1	4	• RADIOLOGICAL SAFETY—EASILY CONTAINED, MODERATE, AIRBORNE
2,1,0,-1,-2	4	• WASTE GENERATION—LOW VOLUME/EASY DISPOSAL → HIGH VOLUME/DIFFICULT DISPOSAL
1,0,-1	4	• NEED FOR DISASSEMBLY—NONE, MODERATE, COMPLETE
1,0,-1	3	• ACCESSIBILITY— >3 BENDS/ELBOWS, 1-3 BENDS/ELBOWS, SINGLE LENGTH
1,0,-1	3	• SIZE OF ITEM—SECTIONING: NONE, MODERATE, EXTENSIVE
1,0,-1	3	• CAPITAL COST—LOW, MEDIUM, HIGH
1,0,-1	3	• OPERATING COST—LOW, MEDIUM, HIGH
1,0	2	• REQUALIFICATION—NO IMPACT, SERIOUS IMPACT
0,-1,-2	2	• CORROSIVENESS—NONE, GENERAL/MODERATE, RAPID/PITTING
1,0	1	• INDUSTRIAL SAFETY—LOW RISK, MODERATE, HIGH RISK

GENERIC COMPONENT GROUPINGS USED FOR COMPARISON OF IN-PLACE NONCHEMICAL DECONTAMINATION TECHNIQUES

- HEAT EXCHANGER TUBING
- PIPE ONE TO 20 IN. I.D.
- TANKS, FILTER HOUSINGS, AND PIPE 28 IN. I.D. AND LARGER
- TANKS WITH INTERNAL COMPONENTS
- VALVES AND PUMPS

TABLE 4-2

IN-PLACE DECONTAMINATION

Component Category: Pipe One to 20 In. I.D.

Note: Subtotal and total values are the product of the grading factor indicated in the matrix and the weighting factor.

GRADING FACTOR	WEIGHTING FACTOR	COMPARISON CRITERIA EFFECTIVENESS OF TECHNIQUE
2,0,-1	4	Loose Debris Removal
2,0,-1	2	Adherent Particle Removal
2,0,-1	2	Removal From Crevices
1,0,-1	2	Production Rate
1,0,-1	2	Remote Operation
1,0,-1	2	Degree of Development
		SUBTOTAL
		IMPACT OF TECHNIQUE
1,0,-1	4	Radiological Safety
2,1,0,-1,-2	4	Waste Generation
1,0,-1	3	Accessibility
1,0,-1	3	Capital Cost
1,0,-1	3	Operating Costs
1,0	2	Requalification
0,-1,-2	2	Corrosiveness
1,0	1	Industrial Safety
		SUBTOTAL
		TOTAL

	DECONTAMINATION TECHNIQUE														
	Mech. Methods, Pigs	High-Pressure Water	Ultra-High-Pressure Water	Water Abrasive Blasting	Pumped Abrasive Blasting	Strippable Coatings	Steam Cleaning	Dry Ice Blasting	Decontamination Foams, Gels, & Pastes	In Situ Electropolishing	Alternative Electrolyte Techniques	Reflux Decontamination	Mech. Methods, Pushed Brushes	Mech. Methods, Rotated Brushes	
	2	2	2	2	2	2	-1	0	-1	-1	-1	0	-1	2	2
	2	0	2	2	2	0	0	2	0	2	2	2	2	2	2
	-1	2	2	2	0	-1	-1	0	-1	0	-1	0	0	-1	0
	1	1	1	1	0	-1	0	1	0	-1	-1	0	0	1	1
	1	0	0	0	1	-1	1	0	1	-1	-1	1	1	0	0
	1	1	0	1	-1	0	1	-1	0	1	1	0	-1	1	1
	16	16	18	20	12	2	-2	4	-4	-2	-4	6	0	14	16
	1	0	0	0	1	-1	1	0	-1	-1	-1	1	1	0	0
	1	1	1	-2	-2	0	0	2	-1	-1	0	-1	0	1	1
	1	0	-1	0	1	-1	1	-1	1	0	-1	1	1	-1	-1
	1	0	-1	0	-1	1	0	-1	0	0	0	0	0	1	1
	1	0	0	0	0	-1	1	0	1	0	0	1	1	0	0
	1	1	1	1	1	1	1	1	1	1	1	1	1	1	1
	0	0	0	0	0	0	-1	0	-1	-1	-1	-1	-1	0	0
	1	0	0	0	1	0	0	0	0	0	0	0	0	1	1
	20	6	0	-6	-1	-5	10	4	6	-8	-7	6	10	7	7
	36	22	18	14	11	-3	8	8	2	-10	-11	12	10	21	23

SUMMARY OF IN-PLACE DECONTAMINATION TECHNIQUE COMPARISON

HEAT EXCHANGER TUBING

Technique	Effectiveness	Impacts	Total Score	Criterion Affecting Score
Mechanical Methods, Propelled Devices	16	16	32	
High-Pressure Water	6	2	8	Radiation Safety
Ultrahigh-Pressure Water	8	-4	4	Accessibility, Radiation Safety
Pumped Abrasive Slurry	8	-5	3	Waste Generation
Water Abrasive Cleaning	10	-10	0	Waste Generation, Radiation Safety

PIPE, ONE TO 20 IN. I.D.

Mechanical Methods, Pigs	16	20	36	
Mechanical Methods, Rotated Brushes	16	7	23	
High-Pressure Water	18	6	22	
Ultrahigh-Pressure Water	18	0	18	Accessibility, Cost
Water Abrasive Cleaning	20	-6	14	Waste Generation
Pumped Abrasive Slurry	12	-1	11	Waste Generation

TANKS, FILTER HOUSINGS, AND PIPE 28-IN. I.D. AND LARGER

Tanks and Filter Housings				
High-Pressure Water	18	9	27	
Ultrahigh-Pressure Water	20	6	26	
Water Abrasive Cleaning	22	-3	19	Waste Generation
Pipe 28-In. I.D. and Larger				
Mechanical Methods, Pigs	14	20	34	
Mechanical Methods, Rotated Brushes	14	17	31	

SUMMARY OF IN-PLACE DECONTAMINATION TECHNIQUE COMPARISON

(Continued)

TANKS WITH INTERNAL COMPONENTS

Technique	Effectiveness	Impacts	Total Score	Criterion Affecting Score
High-Pressure Water	18	9	27	
Ultrahigh-Pressure Water	20	6	26	
Water Abrasive Cleaning	22	-3	19	Waste Generation

VALVES AND PUMPS

High-Pressure Water	16	6	22	
Ultrahigh-Pressure Water	18	3	21	Cost
Water Abrasive Cleaning	20	-6	14	Waste Generation
Pumped Abrasive Slurry	12	0	12	Waste Generation
Mechanical Methods, Rotated Brushes/Hones	8	2	10	Degree of Disassembly, Radiation Safety

TABLE 4-7

OFF-SYSTEM DECONTAMINATION

Component Category: Off-System Decontamination for Reuse of Components

Note: Subtotal and total values are the product of the grading factor indicated in the matrix and the weighting factor.

GRADING FACTOR	WEIGHTING FACTOR	COMPARISON CRITERIA
2,0,-1	4	EFFECTIVENESS OF TECHNIQUE Loose Debris Removal
2,0,-1	2	Adherent Particle Removal
2,0,-1	2	Removal From Crevices
1,0,-1	2	Production Rate
1,0,-1	2	Remote Operation
1,0,-1	2	Degree of Development
		SUBTOTAL
		IMPACT OF TECHNIQUE
1,0,-1	4	Radiological Safety
2,1,0,-1,-2	4	Waste Generation
1,0,-1	3	Size
1,0,-1	3	Capital Cost
1,0,-1	3	Operating Costs
1,0	2	Requalification
0,-1,-2	2	Corrosiveness
1,0	1	Industrial Safety
		SUBTOTAL
		TOTAL

	DECONTAMINATION TECHNIQUE							
	Mech. Methods, Rotated Brushes/Homes	High-Pressure Water	Ultrahigh-Pressure Water	Water Abrasive Blasting	Immersion Electropolishing	FREON Cleaning	Vibratory Finishing	Ultrasonics With Acid
	2	2	2	2	0	2	2	2
	2	0	2	2	2	0	2	2
	0	2	2	2	0	2	0	2
	-1	0	0	0	1	0	1	0
	-1	0	0	0	1	0	1	1
	1	1	0	1	1	1	1	1
	10	14	16	18	10	14	18	20
	-1	0	0	0	1	0	1	1
	2	1	1	-2	-1	2	1	-1
	1	1	1	1	0	1	-1	0
	1	0	-1	0	0	-1	-1	0
	-1	-1	-1	-1	0	-1	0	1
	1	1	1	1	1	1	1	1
	0	0	0	0	-1	-2	0	-1
	0	0	0	0	0	1	1	0
	9	6	3	-6	0	4	5	3
	19	20	19	12	10	18	23	23

SUMMARY OF OFF-SYSTEM DECONTAMINATION TECHNIQUE COMPARISONS

Technique	Effectiveness	Impacts	Total Score	Criterion Affecting Score
Vibratory Finishing	18	5	23	Item Size
Ultrasonics	20	3	23	Waste Generation
High-Pressure Water	14	6	20	
Mechanical Methods, Rotated Brushes/Hones	10	9	19	
Ultrahigh-Pressure Water	16	3	19	
FREON Cleaning	14	4	18	Corrosiveness
Abrasive Cleaning	18	-6	12	Waste Generation
Electropolishing	10	0	10	Waste Generation

TECHNIQUES REQUIRING ADDITIONAL DEVELOPMENT AND/OR ENGINEERING DEMONSTRATION

IN-PLACE DECONTAMINATION

INDUSTRIALLY DEVELOPED, BUT NO NUCLEAR USE

- PROPELLED DEVICES
- PLASTIC PLUGS AND SCRAPERS
- BRUSH/HONE DEVICES

BASIC DEVELOPMENT REQUIRED

- ULTRAHIGH-PRESSURE WATER
- PUMPED ABRASIVE SLURRIES
- FOAMS, GELS, AND PASTES

PROVEN NUCLEAR USE, BUT IMPACT PROBLEM

- ABRASIVE BLASTING
- IN SITU ELECTROPOLISHING

TECHNIQUES REQUIRING ADDITIONAL DEVELOPMENT AND/OR ENGINEERING DEMONSTRATION

(Continued)

NEW TECHNIQUE, LIMITED INDUSTRIAL DEVELOPMENT

- **CHILLED ICE BLASTING**
- **XENON-QUARTZ LAMP HEATING**

OFF-SYSTEM DECONTAMINATION

BASIC DEVELOPMENT REQUIRED

- **DRY ICE BLASTING**

PROVEN NUCLEAR USE, BUT IMPACT PROBLEM

- **IMMERSION ELECTROPOLISHING**
- **ULTRASONICS**

TMI-2 WASTE MANAGEMENT

OVERVIEW AND UPDATE ON WASTE MANAGEMENT ISSUES AT TMI-2:
R. S. Daniels (Bechtel National), T. W. McIntosh (DOE-HQ),
J. K. Reilly, (DOE-Idaho TMI)

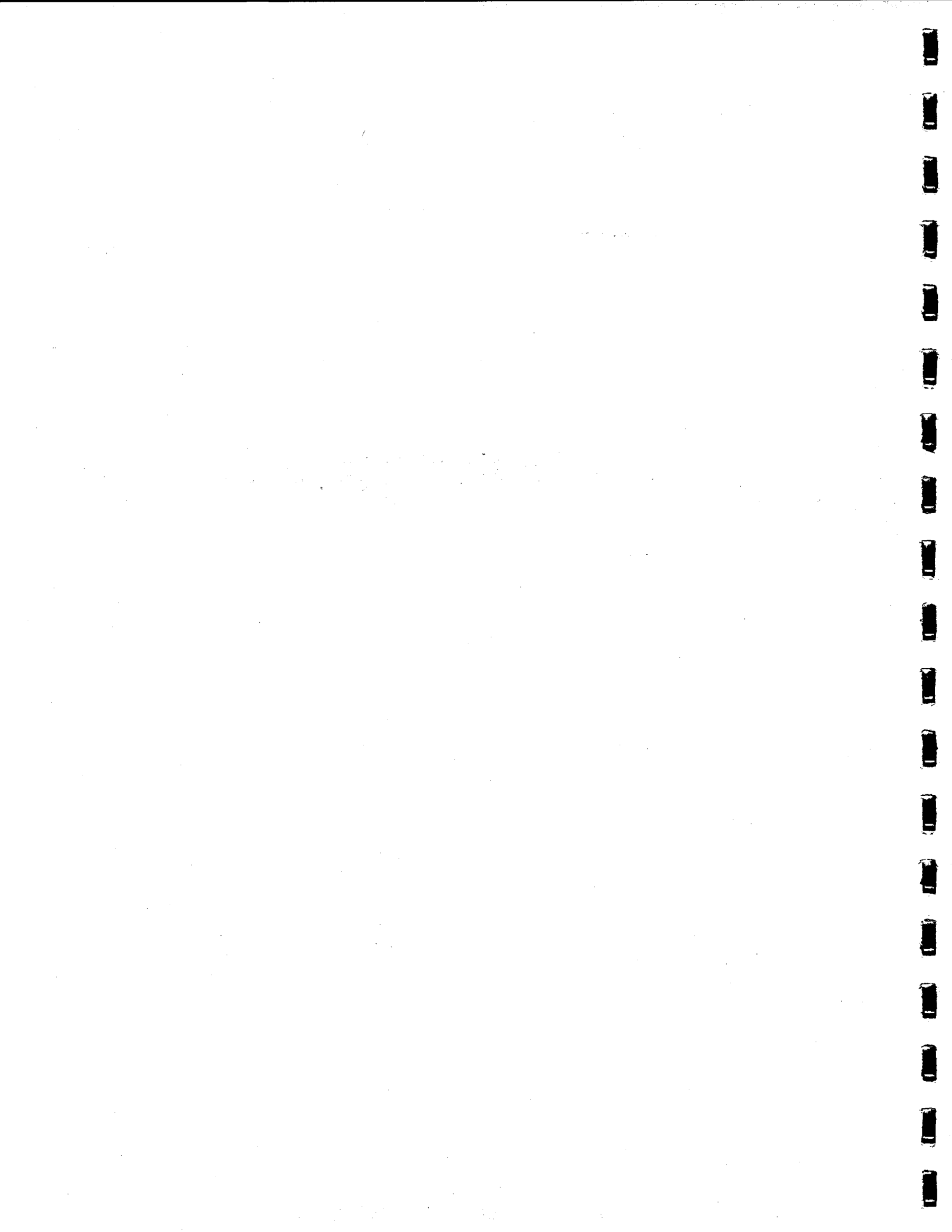

OVERVIEW AND UPDATE ON WASTE MANAGEMENT ISSUES AT TMI-2

R. S. Daniels
Bechtel National, Inc.
15740 Shady Grove Road
Gaithersburg, MD 20877

T. W. McIntosh
U.S. Department of Energy
Division of TMI Programs
Washington, DC 20545

J. K. Reilly
U.S. Department of Energy
TMI Site Office
P.O. Box 88
Middletown, PA 17057

Cleanup and decontamination from the March 28, 1979 accident at Three Mile Island is producing large quantities of radioactive waste. Uncovering of the reactor core for several hours and its subsequent quenching by steam and water released fission products which have created waste management problems not previously encountered with the commercial reactor program. These problems are in the areas of processing, temporary storage, packaging, shipment and disposal. The purpose of this paper is to provide an overview of the solution of these problems which are discussed in greater detail by the papers which follow in this session.

Status

Radioactively contaminated water (2000m^3) in the Auxiliary and Fuel Handling Building (AFHB) was processed by an ion exchange system (EPICOR-II) designed to handle cesium and strontium in the range of 1 to 100 uCi/ml. The only radionuclide of significance remaining after processing is tritium with an activity less than 1uCi/ml. Water in the Reactor Building basement has been successfully processed in the Submerged Demineralizer System (SDS), a zeolite ion exchange system, specifically designed to process these higher

activities (greater than 100 uCi/ml). A modified EPICOR-II system was used to polish the effluents from the SDS. Approximately 2300m³ of water was processed.

In order to permit various prehead lift examinations it is desirable to reduce radioactivity levels in the reactor coolant system (RCS) to less than 1uCi/ml. The SDS is being used to process the RCS by bleed and feed techniques--returning the processed water to the RCS. The RCS volume is 340m³. Approximately 7 to 10 RCS volumes are being processed in 190m³ batches to accomplish this objective.

A summary of the quantities of liquids processed, radioactivity removed and number of ion exchange liners produced is presented in Table 1.

Due to high specific activity and unusual character of the wastes produced during decontamination of the accident water, commercial disposal for some of the wastes is not available. The Department of Energy in conjunction with the Nuclear Regulatory Commission concluded a Memorandum of Understanding to provide agreement for R&D and/or disposal of these wastes.

Fifty EPICOR-II prefilter liners, resulting from the processing of AFHB basement water, contain approximately 1300Ci of radiocesium per cubic meter of resin. Concern was expressed as to the stability of the irradiated resins and the integrity of the treated carbon steel liners. Radiolytic decomposition of water remaining in the resin void space was postulated. One of the fifty liners in temporary storage at TMI was vented of its hydrogen and shipped to Battelle Columbus Laboratories for examination in 1981 and then to INEL in 1982 for further examination. In parallel with the characterization effort, a research and development program was begun to design, fabricate and test a prototype high integrity container to permit the disposal of a group of the prefilters in low level waste burial without immobilization. In addition, a prototype gas sampler for inerting the EPICOR-II prefilters was developed by EG&G at the Idaho National Engineering Laboratory (INEL). Venting, inerting, sampling and handling of EPICOR-II prefilters is accomplished at TMI-2 utilizing the sampler in a 30 ton concrete blockhouse. The second

and third of the fifty prefilters were shipped to BCL in August 1982. The remaining liners will be shipped to INEL for examination and immobilization research and development or disposition in the high integrity container.

During the accident the makeup and purification system became contaminated. Five makeup filters are being examined at INEL for waste characterization to support removal of the makeup and demineralizer resins from the AFHB.

The SDS system using inorganic zeolite was developed to process the Reactor Building basement water and the RCS. SDS liners after shipment to Richland, Washington, will be vitrified by the DOE as part of its waste immobilization research and development program at the Batelle Pacific Northwest Laboratories (PNL) or be disposed of in greater confinement burial. A maximum of approximately 55,000Ci of cesium and strontium has been deposited on a single SDS liner to minimize the number of waste packages. The high radioactivity loadings have resulted in significant hydrogen generation due to radiolytic decomposition of the water in the zeolite void space. Special techniques have been developed by the DOE and GPUNC for vacuum drying, and recombination of hydrogen and oxygen gases using a platinum/palladium catalyst inside the vessel. Vitrification of the zeolite from a low activity (7,000Ci of Cs and Sr) liner is scheduled to be performed at PNL during 1982.

Challenges

- A number of waste management problems are on the horizon including:
- o Removal and packaging of the AFHB makeup and purification demineralizer system resins.
 - o Volume reduction of solid wastes from decontamination.
 - o Removal and packaging of transuranic wastes from filters and tank sludge.
 - o Processing of chemical decontamination solutions.
 - o Removal and packaging of reactor building sump sludge.
 - o RCS and connected systems decontamination.
 - o Refueling canal cleanup system.

Resolution of these problems will be addressed during subsequent stages of recovery.

TABLE 1
**WASTE PROCESSING
 ACCOMPLISHMENTS**

AUXILIARY/FUEL HANDLING BLDG BASEMENT WATER - 2,000 m³

	Media	
• EPICOR II System:	Volume - m ³	Cs-137,-134
50 Prefilters	0.9	55,000 Ci
15 Cation IX	3.4	240 Ci
7 Mixed Bed IX	3.4	24 Ci

REACTOR BUILDING BASEMENT WATER - 2,300 m³

	Media				
• Submerged Demineralizer System:	Volume - m ³	Cs-137	Cs-134	Sr-90	Sb-125
9 Zeolite Liners	0.2	278,000 Ci	30,000 Ci	11,600 Ci	—
• EPICOR II System					
30 Cation 1X	3.4	2.0 Ci	0.2 Ci	20 Ci	25 Ci
4 Mixed Bed 1X	3.4				

REACTOR COOLANT SYSTEM WATER - 570 m³ PROCESSED

• Submerged Demineralizer System:	Cs-137	4,000 Ci;	Sr-90	5,700 Ci
--------------------------------------	--------	-----------	-------	----------

SPECIAL HANDLING REQUIREMENTS FOR HIGHLY LOADED ORGANIC RESINS:
R. E. Ogle, J. M. Bower (EG&G Idaho, Inc.),
T. E. Rekart (GPU Nuclear)

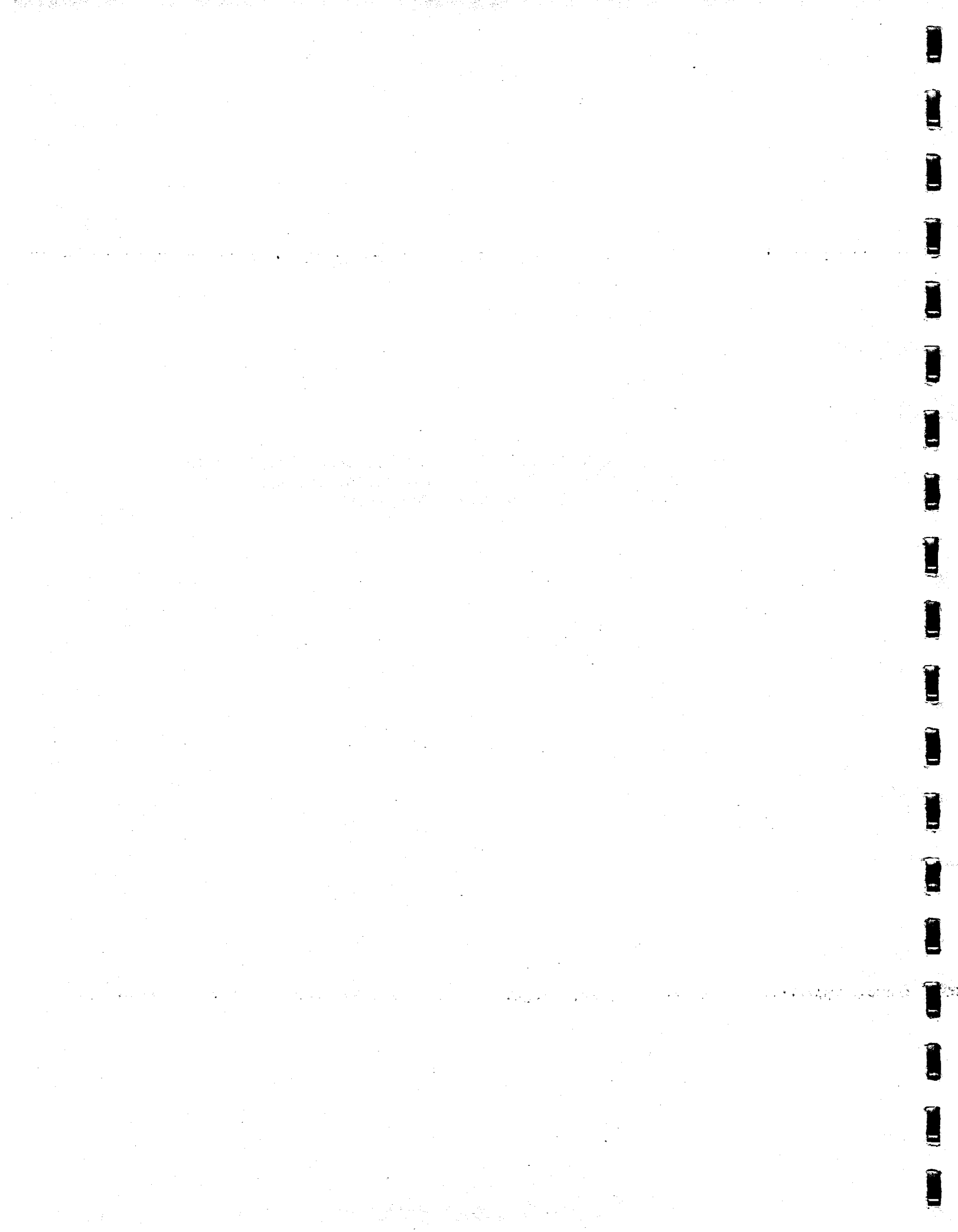

SPECIAL HANDLING REQUIREMENTS
FOR
HIGHLY LOADED ORGANIC RESINS*

R. E. Ogle, EG&G Idaho, Inc.
J. M. Bower, EG&G Idaho, Inc.
T. E. Rekart, GPU Nuclear Corp.

The March 28, 1979 accident at the Three Mile Island Nuclear Power Station Unit 2 (TMI-2) resulted in the transfer of more than 1900 m³ of contaminated water to the auxiliary and fuel handling buildings. This water was later processed through a three-stage ion exchange system called EPICOR II. The first stage of this system, designated prefilters (PF), removed the bulk of the radioactivity, mainly cesium and strontium. The U.S. Department of Energy (DOE), through its subcontractor, EG&G Idaho, Inc., and the General Public Utilities Nuclear Corporation (GPUNC) recently began shipments of highly loaded EPICOR II prefilter liners to a DOE laboratory for research and disposition. One of these prefilter liners, PF-16, was selected for characterization because its high curie loading of 1250 and low residual water pH of 2.79 indicated that it was one of the most likely liners to demonstrate any potential damage from exposure to such conditions.

GPUNC readied PF-16 for shipment by partially unscrewing the vent plug for 16 hours and then completely removing the plug for one hour. This venting was performed to remove any combustible gases present. The PF-16 liner was then loaded into a shipping cask and shipped to Battelle Columbus Laboratories (BCL) on May 19, 1981.

* Work supported by the U.S. Department of Energy, Assistant Secretary for Nuclear Energy, Office of Coordination and Special Projects, under DOE Contract No. DE-AC07-76ID01570.

On May 29, 1981 BCL obtained a gas sample from the liner prior to removing the manway cover. The subsequent gas sample analysis indicated a hydrogen concentration slightly above 12% by volume, which was higher than expected since the liner had been vented 10 days earlier. Based on the amount of hydrogen found, it was decided that the rest of the liners should be handled and prepared for shipment (including purging each liner with inert gas) by a more remote and effective technique. In the summer of 1981, EG&G Idaho, Inc. began preliminary design work on a Prototype Gas Sampler (PGS).

The PGS was developed to remotely remove the prefilter liner vent plug, capture the gases released, and purge the liner with inert gas. These remote venting, sampling, and purging capabilities are necessary due to the high radiation fields around the liners and the possible presence of combustible gases in the liners. The PGS, an air-driven device, operates on the liners while they are housed in their storage modules at the TMI Solid Waste Staging Facility. The major components of the system for using the PGS at TMI are a portable concrete shielding structure, a PGS support and positioning assembly, and a remote support facility--the command center for all operations.

The concrete shielding structure is 46 cm thick, contains shielded viewing windows, and provides a platform for the PGS support and positioning assembly. The PGS is connected to the remote support facility by a 30-m umbilical that carries TV camera signals, power, lighting, compressed air, and gas handling lines. The mobile remote support facility contains the PGS control panel, video monitors, gas sampling and analysis capabilities, air compressor, a high efficiency particulate activity (HEPA) filter unit, and communication equipment.

Once all support equipment is positioned and the EPICOR II liner storage cell shield block has been removed, the cell is inerted with nitrogen. The PGS is then lowered onto the liner and roughly positioned using the liner's lifting lugs as indexing guides. Precise positioning of the PGS over the liner vent plug is accomplished using air-driven threaded adjustments. The PGS operator uses a built-in TV system to monitor the positioning.

After the tool is engaged in the liner vent plug, the sampler is lowered until the shroud around the tool is sealed against the liner top. A window in the shroud allows TV system monitoring during removal and installation of the plug.

The drive system for removing, installing, and lifting the plug consists of a pneumatic torque wrench and ball-bearing spline. This spline permits vertical movement of the plug during unthreading, threading, and lifting of the plug. The plug is unscrewed and then lifted clear of the port to allow gases to pass into the shroud. Upon completion of sampling, venting, and purging the plug is lowered back into the port and tightened, thereby resealing the container for shipment.

The PGS is raised from the liner into the shielded enclosure, the storage cell is ventilated through the HEPA unit, and the PGS assembly is removed from the storage cell. At this point the liner can be retrieved from its storage cell and placed into a cask for shipment.

Functional testing of the PGS and its support components demonstrated that the PGS can be effectively used at TMI to vent and inert a mockup EPICOR II liner. Present plans call for the actual venting, inerting, and shipping of the EPICOR II liners at TMI to begin in August 1982.

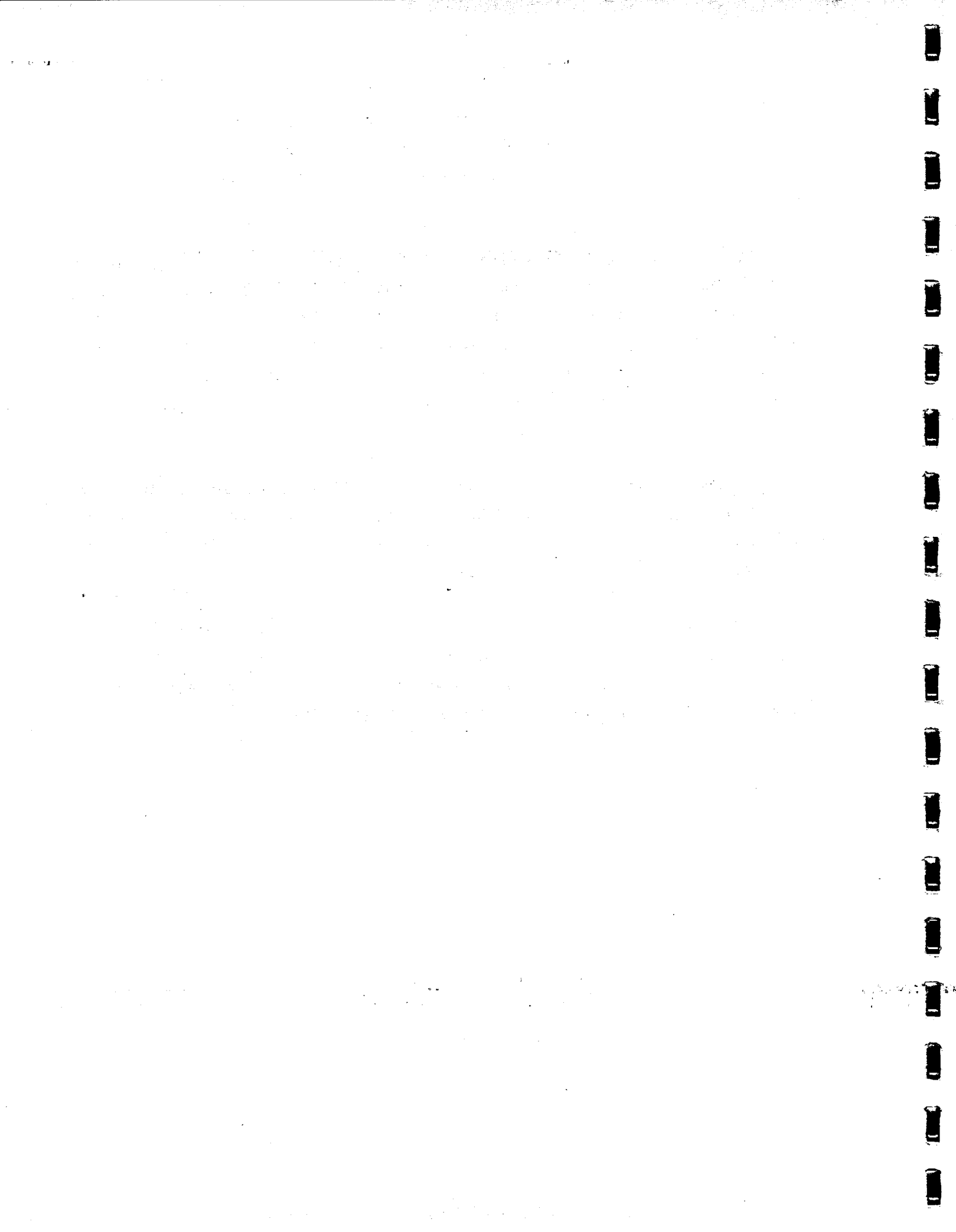

Special Handling Requirements for Highly Loaded Organic Resins

Presented by

R. E. Ogle, EG&G Idaho, Inc.
J. M. Bower, EG&G Idaho, Inc.
T. E. Rekart, GPU Nuclear Corp.



IDAHO NATIONAL ENGINEERING LABORATORY



TMI-2 EPICOR II System

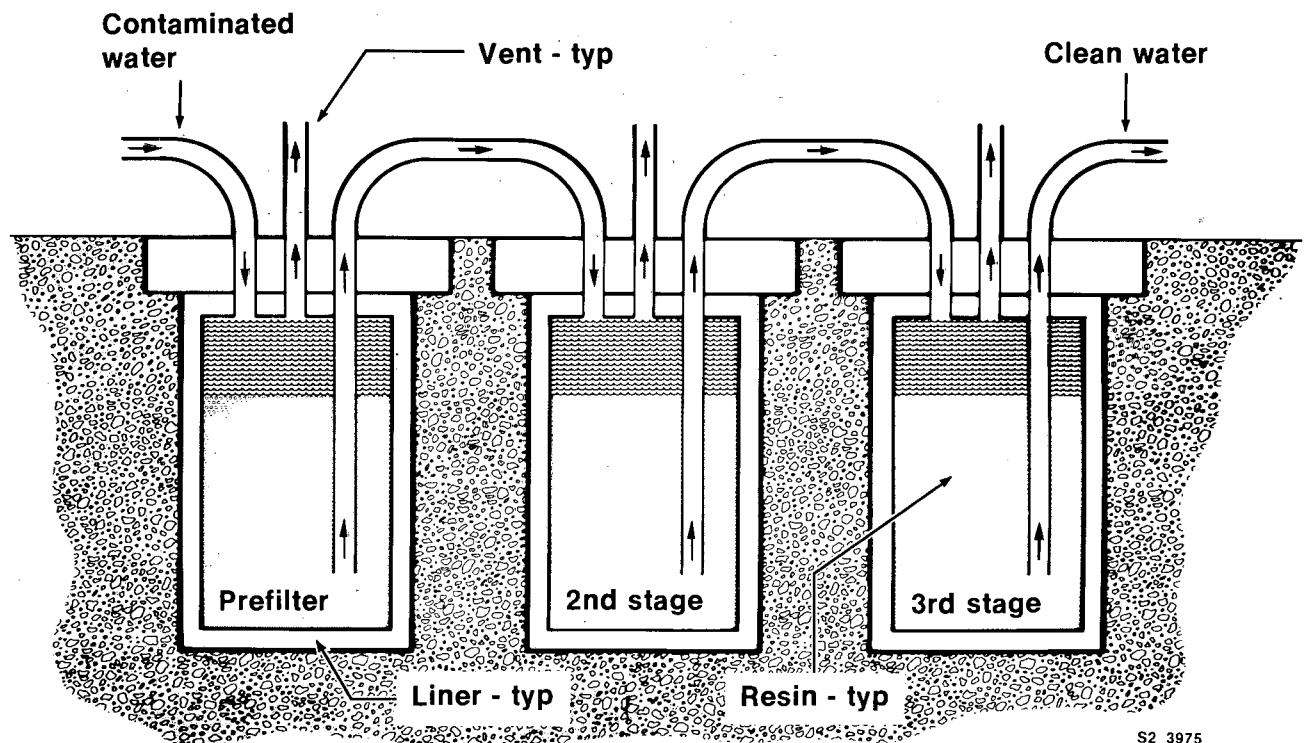

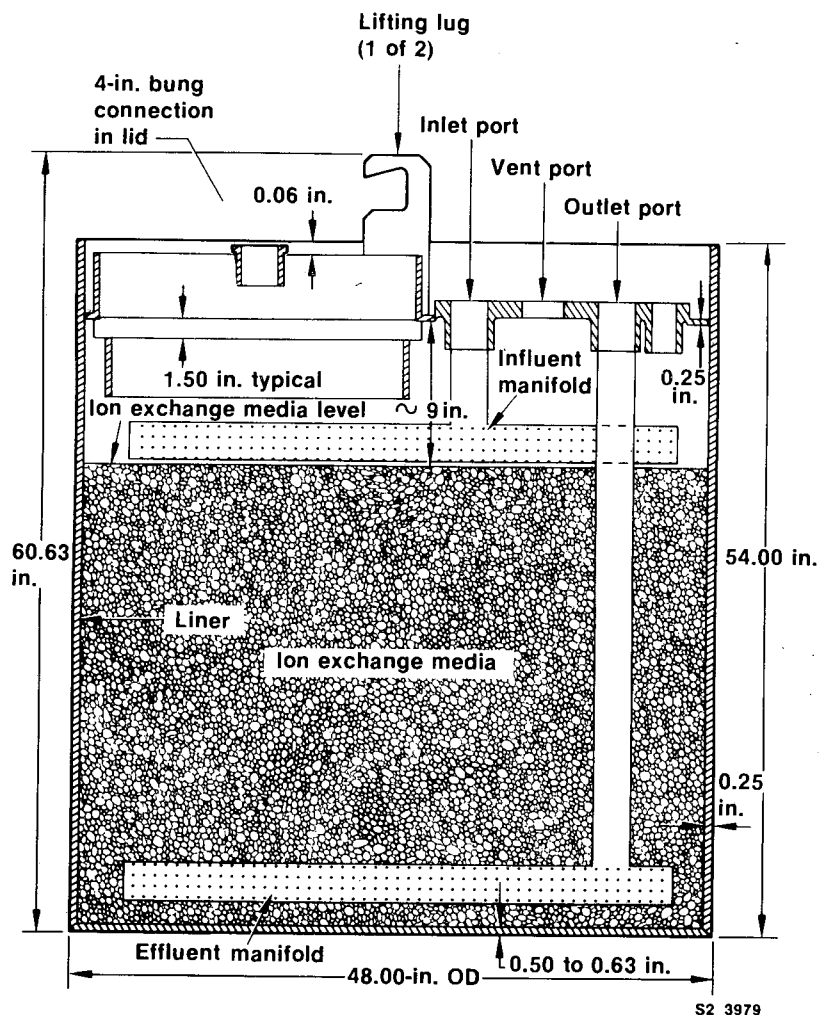

Gas Analysis at Battelle Columbus Laboratories

Volume %
PF-16 Sample 1

Carbon dioxide	5.52	±	0.06
Argon	0.96	±	0.05
Oxygen	0.20	±	0.02
Nitrogen	80.6	±	0.4
Carbon monoxide	0.2	±	0.02
Hydrogen	12.4	±	0.2

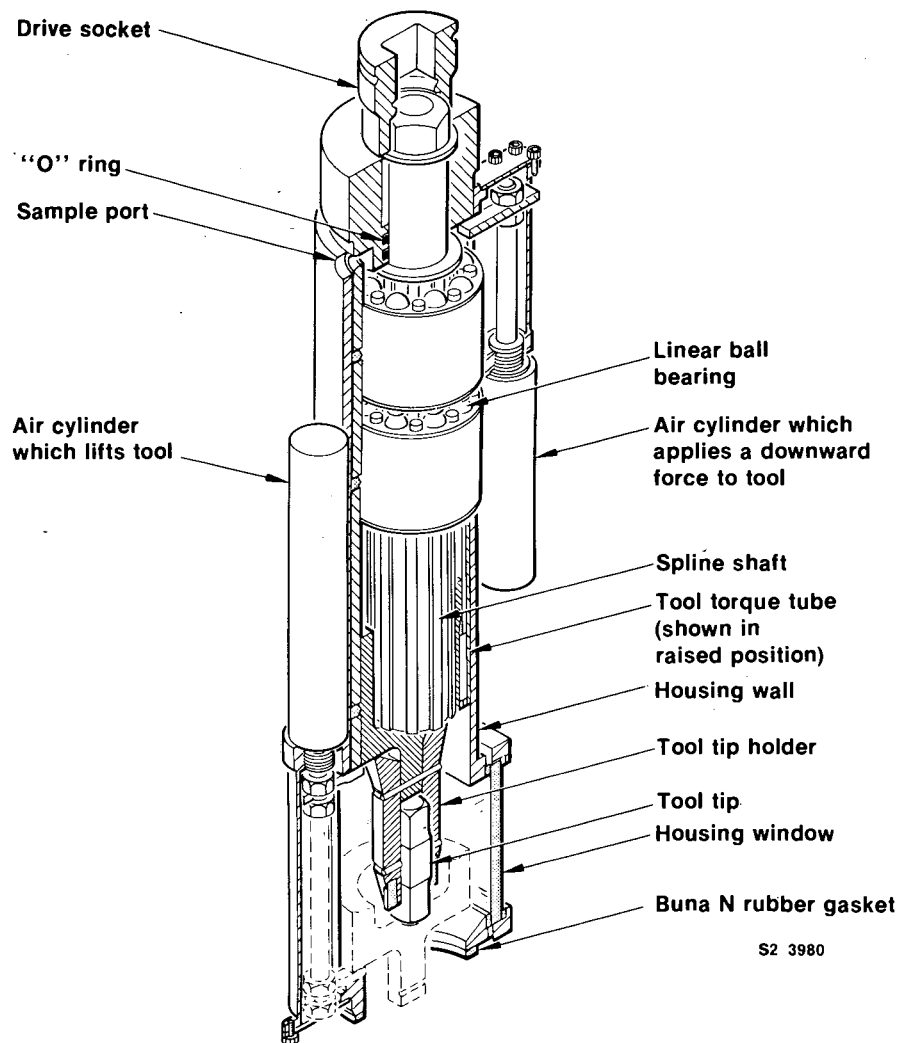

Results of Sampling EPICOR PF - 3

- Curie loading **1878**
- Initial conditions
 - Gas composition **9.9% H₂, 0% O₂, 87.5% N₂**
 - Pressure **less than .1 PSIG**
 - Kr 85 **less than 1.5 E⁻⁵ μCi/cc**
- Hydrogen generation rate **.0227% Increase per day**
- Final gas composition **.4% H₂, .1% O₂, 98.27% N₂, 1.2% CO₂**
- Predicted gas composition after shipment (at 16 days) **3.0% H₂, 0.0% O₂, 86.07% N₂, 11% CO₂**

NOTE: percentages are volume percent

Summary

Results of Sampling EPICOR Pre-Filters

LINER	Date of sampling	Curie loading	Initial conditions			
			Pressure (PSIG)	Volume %		
				H ₂	O ₂	N ₂
PF - 16 *	May 29, 1981	2250	0	12.4	0.2	80.6
PF - 3	July 27, 1982	1878	0.1	9.9	< 0.5	87.5
PF - 1	August 19, 1982	1498	0.0	3.6	< 0.5	—
PF - 2	August 27, 1982	1052	0.3	4.5	< 0.5	92.8
PF - 6	September 21, 1982	166	-1.3	0	< 0.5	95.0
PF - 7	September 27, 1982	1402	0	3.6	< 0.5	91.4
PF - 8	October 7, 1982	1367	0	8.0		

* Sampled after arrival at BCL

RESEARCH AND DISPOSITION OF HIGHLY LOADED ORGANIC RESINS:
R. C. Schmitt, K. C. Sumpter (EG&G Idaho, Inc.)

THE UNIVERSITY OF CHICAGO
LIBRARY

RESEARCH AND DISPOSITION OF HIGHLY LOADED ORGANIC RESINS*

R. C. Schmitt, EG&G Idaho, Inc.

K. C. Sumpter, EG&G Idaho, Inc.

The March 1979 accident at Three Mile Island Unit 2 resulted in the accumulation of about 1900 m³ (500,000 gallons) of contaminated water in the Auxiliary and Fuel Handling Buildings. Decontamination of this water was completed by use of an ion exchange resin demineralizer system (EPICOR II), resulting in 50 EPICOR II prefilter liners each loaded with up to 9.14×10^{13} Bq of ⁹⁰Sr, ¹³⁴Cs, and ¹³⁷Cs; their daughter products; smaller amounts of Ru, Rh, and Ba; and trace amounts of U and transuranics.

One liner (PF-16) was transported to Battelle Columbus Laboratories (BCL) in Ohio for characterization and then to the Idaho National Engineering Laboratory (INEL) in April 1982. Of the remaining 49 EPICOR prefilter liners, PF-3 will also go to BCL for characterization; the others are scheduled for transport to INEL starting in August 1982. Meanwhile at INEL, design efforts, facility preparations, construction activities, research planning, equipment procurement, and documentation for liner research and disposition are nearly complete.

The 50 EPICOR II liners are to be handled and stored at the INEL Test Area North complex, which includes manufacturing and hot shop facilities. Much of the equipment has been refurbished sufficiently for liner receipt.

* Work supported by the U.S. Department of Energy, Assistant Secretary for Nuclear Energy, Office of Coordination and Special Projects, under DOE Contract No. DE-AC07-76ID01570.

Construction of storage silos has been ongoing; the first one is now complete. The storage silo has a removable lead lid and is a double-walled steel vessel with lead-filled walls. Venting systems and combustible gas detectors are part of the design. The silo unit sits over an existing turntable in the hot shop and accommodates up to 24 liners. Three existing temporary storage casks have been refurbished and three new casks fabricated to further facilitate handling.

The PF-16 liner characterized at BCL is considered typical of liners numbered 12 through 50, which contain resins and zeolite. The other liner going to BCL for characterization (PF-3) typifies those numbered 1 through 11, which contain organic resins only. These two liners are scheduled for liner integrity examinations at INEL.

Only limited examination of the condition of the coated carbon steel liner was conducted at BCL on PF-16. INEL, in storing the liners for the research period (less than 4 years), must have a more complete understanding of the deteriorating effect on coated carbon steel surfaces that may result from highly loaded ion exchange resins. PF-16 and PF-3 are to be emptied, examined, decontaminated, and sectioned for metallographic examination. This PF-16 work was initiated in July 1982.

A share of the INEL EPICOR II Research and Disposition Program is dedicated to resin research. Initially, three each of the two types of liners are identified for evaluation. The two principal objectives are the removal of core samples from the resin bed to evaluate resin degradation as a function of time and the performance of resin solidification studies. Physical, chemical, and radiological examinations are part of the degradation work. The formation of encapsulated samples of the resin bed for physical, leach, and lysimeter tests are part of the solidification work. The lysimeter testing will be performed at four national laboratories in field trials.

Another share of the INEL task, the third research activity, involves an attempt to dispose of one liner at a commercial burial ground using a High Integrity Container (HIC) developed for that purpose. Development, testing, and use of the HIC is a part of this program, and is described in a separate paper.

The successful research and disposition of the TMI EPICOR II liners will benefit the industry in a number of ways:

- o By showing that such wastes can be disposed of in cost effective ways using established technology and within existing regulatory constraints
- o By providing data on the degradation of ion exchange media containing high loadings of radionuclides
- o By providing data on the behavior of coated steel liners containing highly loaded ion exchange media
- o By demonstrating that abnormal radioactive wastes may be disposed of in shallow land facilities using High Integrity Containers as an alternative to solidification
- o By providing data on the efficiency of immobilizing highly-loaded resins and organic resins with zeolite
- o By providing information on the behavioral movements of radionuclides through soils away from highly loaded solidified sample sources.

Information on integrity of liners, behavior of resins with high radiation loadings, and use of High Integrity Containers for burial could be important to planning future cleanup operations. Further knowledge

concerning solidification of resins, resin degradation, radionuclide behavior in environmental media, and efficiency of the HIC should be valuable for the development of new low-level radioactive waste disposal facilities. Very little research has been conducted with ion exchange media containing high loadings of radionuclides held for a period of a year or more. Because of the known adverse effects of high radiation doses on resin chemical properties and the secondary effects of enhanced corrosion on carbon steel and reduced capability to solidify organic resins, the resin research will increase the information base on nuclear grade ion exchange media and containers thereof.

Research and Disposition of Highly Loaded Organic Resins

Presented by

R.C. Schmitt
K.C. Sumpter
H.W. Reno



IDAHO NATIONAL ENGINEERING LABORATORY



EPICOR-II Research and Disposition Program

Major Objectives

- Support TMI-2 recovery
- Safely receive and store 50 EPICOR-II liners for research and disposition
- Perform valuable research on liners and resins
- Dispose of liners and contents as class "C" low level wastes

EPICOR-II Research and Disposition Program

Progress in FY-1982

- Completed all facility preparation activities
- Completed most equipment items
- Prepared research program
- Completed program documentation
- Received and stored PF-16 and PF-1
- Initiated liner exam of PF-16

S2 3984

EPICOR-II Research and Disposition Program

Elements of Receipt and Storage

- Facility preparation
 - Refurbish hot shop and associated equipment
- Fabricate equipment
 - Two silo storage systems
 - Three new storage casks
 - Venting tool
 - Liner decontamination unit
- Prepare major documents
 - Five safety
 - Two environmental
 - Four program
 - Nine operations

S2 3990

EPICOR-II Research and Disposition Program

Elements of Research

- **Liner integrity examinations**
- **Resin degradation studies**
- **Resin solidification and testing**
- **Disposal demonstration**

S2 3989

EPICOR-II Research and Disposition Program

Liner Integrity Examinations

- **Minimum of one all organic liner and one organic/zeolite liner**
- **Develop tools, procedures, and documents**
- **Empty liners and remotely inspect**
- **Decontaminate**
- **Section for metal samples (six or more per liner)**
- **Metallurgical examination of samples**
- **Quantify liner deterioration**

S2 3988

Resin Degradation Studies

- Minimum of two all organic and two organic/zeolite liners
- Six 2-inch - diameter x 29-inch long core samples per liner
- Visual examinations
- Chemical analyses
- Physical analyses
- 10^9 rad resin exposure objective

S2 3987

Resin Solidification and Testing

- Minimum of two all organic and two organic/zeolite liners
- Develop tools, procedures, and documents
- Bench leach tests (from each type of liner)
 - Four resin/cement specimens
 - Four resin/Dow polymer specimens
- Compression tests (from each type of liner)
 - Four resin/cement specimens
 - Four resin/Dow polymer specimens
- Lysimeter field tests (from each type of liner)
 - Four lysimeters at four national labs
 - Four resin/cement specimens
 - Four resin/Dow polymer specimens

S2 3986

EPICOR-II Research and Disposition Program

Disposal Demonstration

- **Develop and test a high - integrity container system**
- **Support GPUN in obtaining a use agreement for container**
- **Dispose of one container with liner at a commercial site on demonstration basis**
- **Dispose of research wastes**
- **Prepare and dispose of remaining liners**

S2 3985

EPICOR-II Research and Disposition Program

Expected Progress in FY-1983

- **Receive and store remaining liners**
- **Complete liner integrity exams**
- **Complete resin solidification specimens**
- **Analyse degradation samples**
- **Fabricate and ship lysimeter field test units**
- **Complete high integrity container testing**
- **Obtain use agreement for container**
- **Complete disposal demonstration**

S2 3983

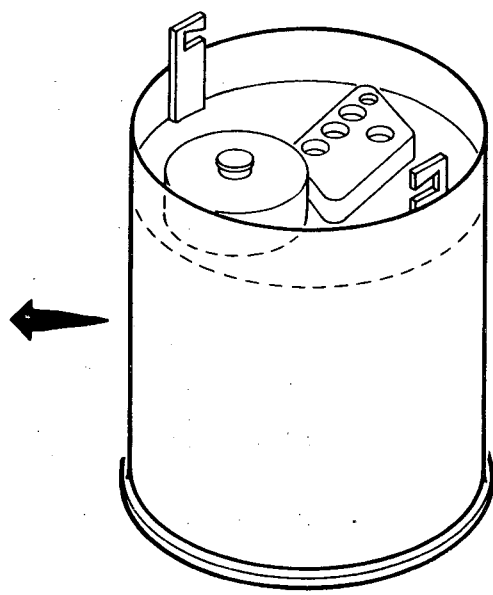
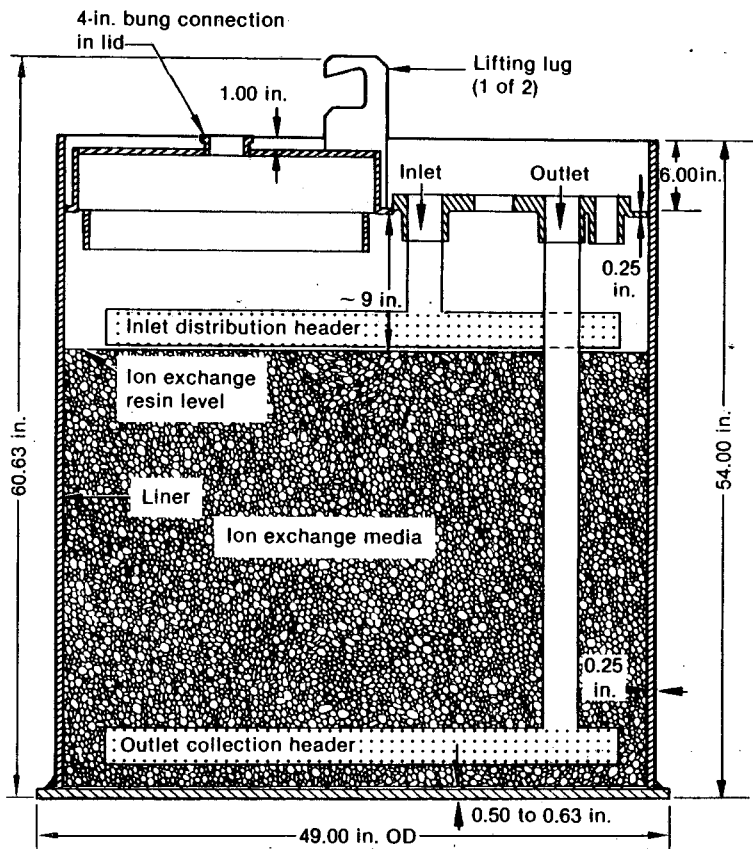

INEL 2 0836

Schematic Diagram of EPICOR-II Liner

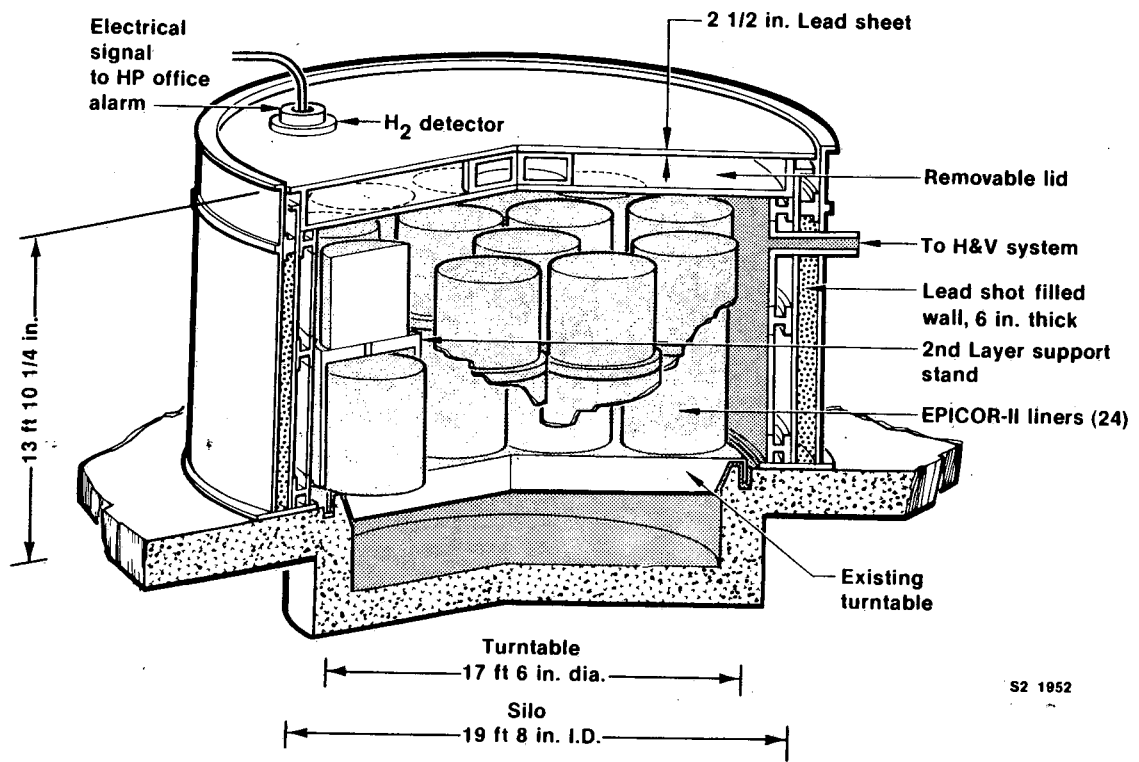

S2 1952

Diagrammatic Representation of TAN-607 Storage Silo

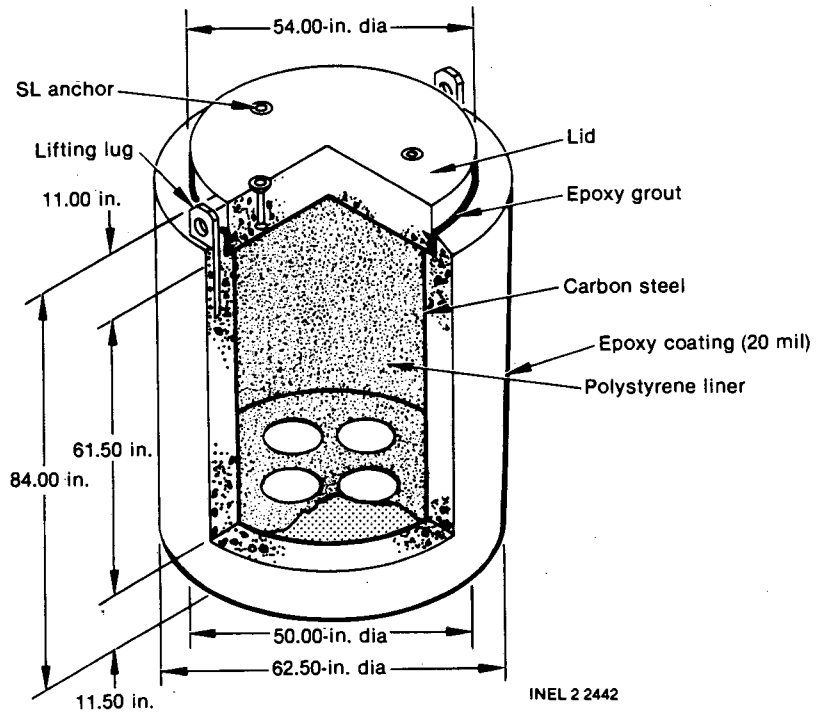

Schematic Diagram of High-Integrity Container

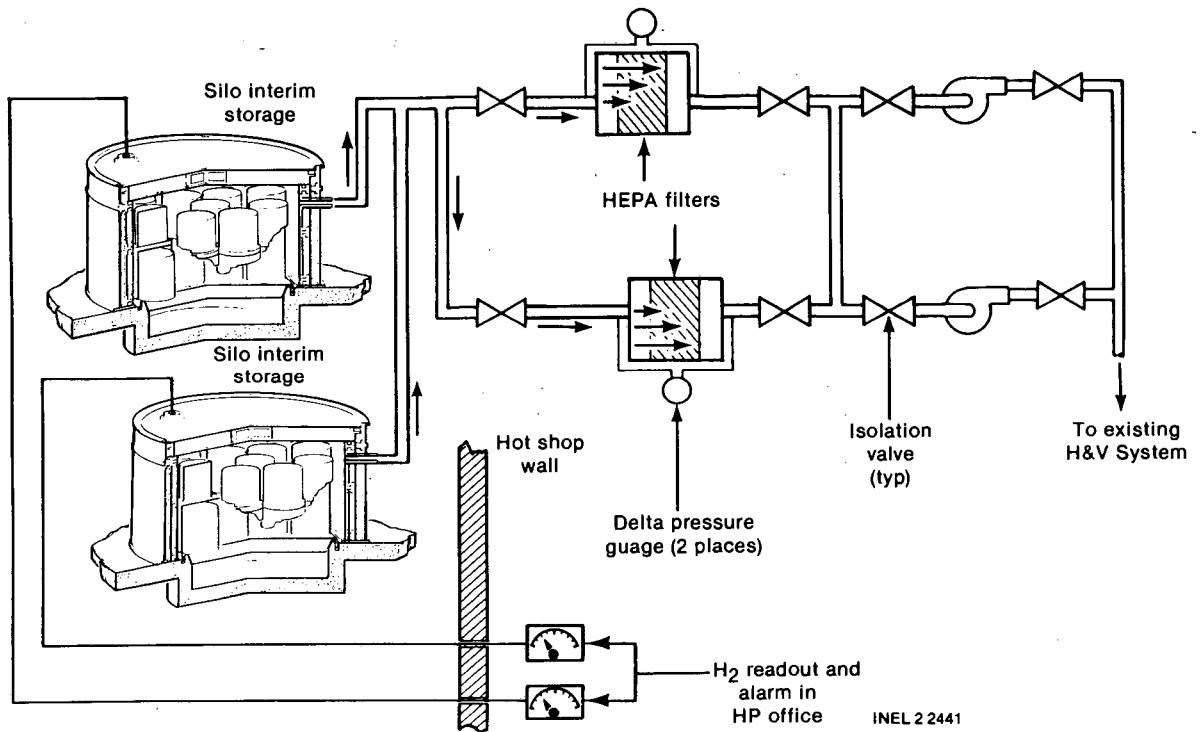

Schematic Diagram of TAN-607 Storage Silo Vent System

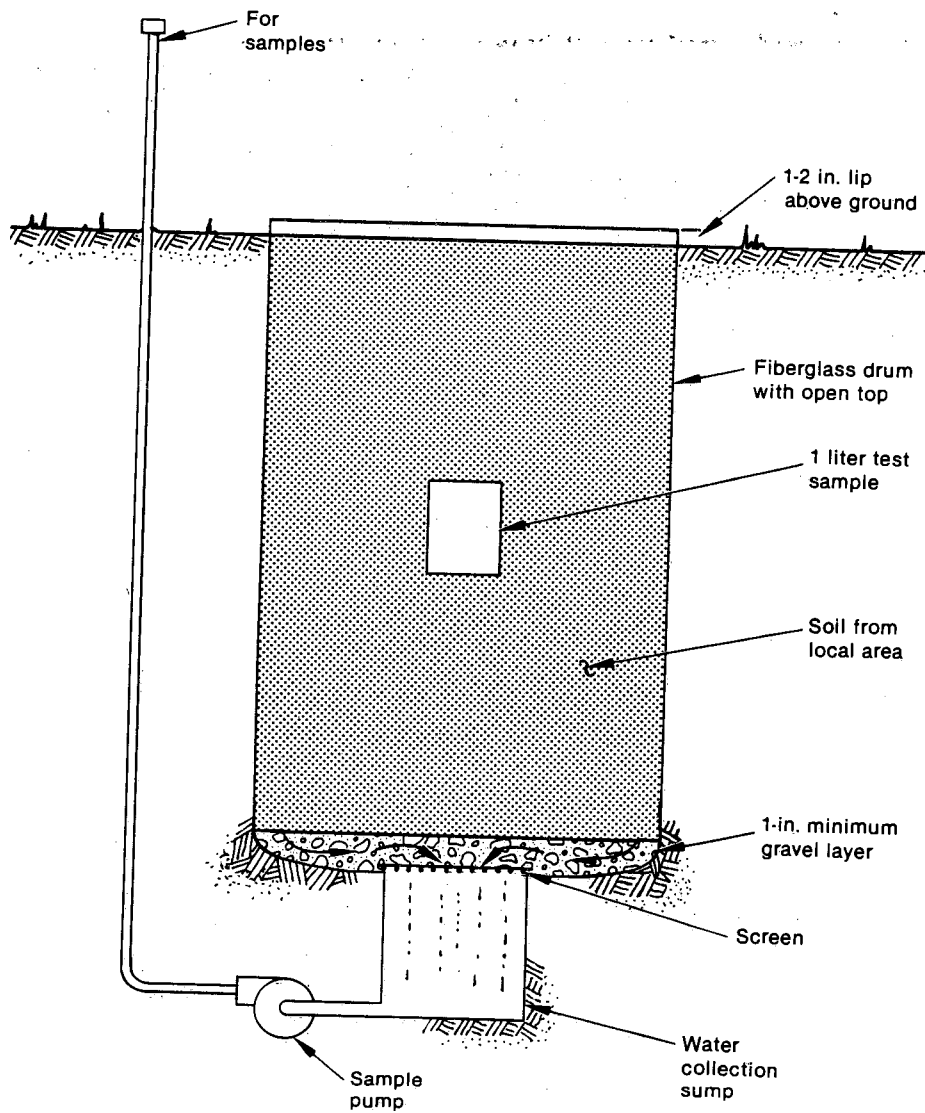

INEL 2 0628

Lysimeter for Field Testing of EPICOR-II Resins

HIGH INTEGRITY CONTAINER FOR HIGH-SPECIFIC ACTIVITY WASTES:
R. L. Chapman (EG&G Idaho, Inc.),
R. T. Haelzig (Nuclear Packaging, Inc.)

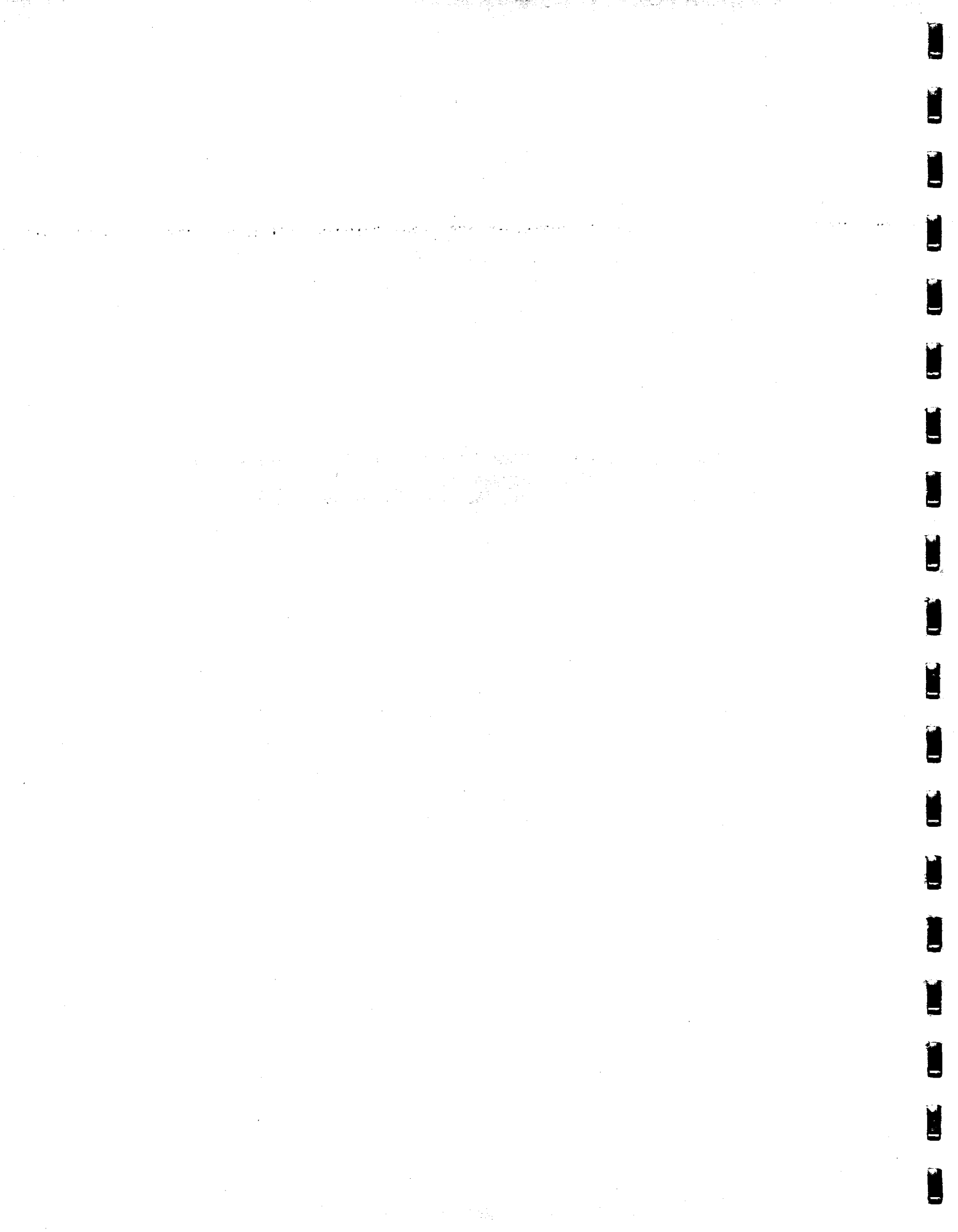

HIGH INTEGRITY CONTAINER FOR
HIGH SPECIFIC ACTIVITY WASTES*

R. L. Chapman, EG&G Idaho, Inc.
R. T. Haelsig, Nuclear Packaging, Inc.

The cleanup of the nuclear plant accident at Three Mile Island's Unit 2 has produced some high specific activity wastes which are not suitable for disposal by conventional means. The purpose of the work described in this paper is to develop a burial container suitable for safely disposing of certain of these wastes in a waste burial ground.

The first step in the container development program was to establish a comprehensive set of requirements to be satisfied by the container. An extensive program to determine requirements was spearheaded by the Transportation Technology Center at Sandia National Laboratories.¹ Table 1 summarizes the key requirements, which are also translated into design goals.

The maximum gas generation rate is conservatively estimated to be 0.052 mole per day. The vent gas system is designed to release this much gas while maintaining its ability to retain water at pressures up to 275 kPa. The vent system consists of 5- μ m pore size stainless steel filter elements, a 3- μ m polyethylene filter assembly, a PVC water trap designed to self-purge infiltrated water as gas is released from the container, and a 3- μ m polyethylene external filter to prevent intrusion of mud and debris. The filter train is surrounded by a lead shield to prevent deterioration of the polyethylene filter materials.

* Work supported by the U.S. Department of Energy, Assistant Secretary for Nuclear Energy, Office of Coordination and Special Projects, under DOE Contract No. DE-AC07-76ID01570.

The structural design was influenced by four requirements: burial depth, stacking, handling, and hydrostatic loads. These resulted in a combined external design load of 1 MPa applied uniformly. Structural design was also influenced by a desire to minimize cost. Other factors that influenced design are chemical environment, life requirements, and radiation field.

The disposable high integrity container consists of a right circular cylinder of reinforced concrete, 1.56 m OD, 2.13 m high, with 0.15-m-thick cylindrical walls, and 0.28-m-thick ends (see Figure 1). The container uses an epoxy-coated carbon steel inner liner which also serves as the inside concrete form. A rebar cage and headed studs welded to the inner liner are used to strengthen and maintain integrity of the concrete shell. A permanently sealed lid is used to close the container after the payload has been placed inside.

The primary migration boundary consists of epoxy materials applied to a carbon steel substrate. The inner surface of the container utilizes the Carboline Company's Phenoline AE-600 system.

Two other migration barriers are provided for redundancy. The outer surface of the carbon steel inner liner is coated with Phenoline 300 orange primer and Phenoline 302 finish. Finally, the outer surface of the concrete will be coated with Carboline 195 surface and Carboline 191 HB. These coatings are nuclear qualified to greater than 10^9 Rad.

Nine kg of hydrated aluminum oxide will be placed inside the container to serve as an amphoteric agent to maintain the pH of the contents to greater than 5. A high-density polyethylene liner will be placed inside the container to protect the epoxy liners from damage due to contact with the payload container. A lead-in collar is placed in the container to protect the finish from chipping or abrasion during loading.

The high integrity container design uses a combination of redundancy, passive elements, and design conservatism to achieve the desired functional life expectancy. Simplicity of design and low-cost materials are used to minimize unit costs. The authors are satisfied that all design requirements and objectives are satisfied by the design.

REFERENCE

1. M. G. Vigil, et al., "Proposed Design Requirements for High Integrity Containers Used to Store, Transport, and Dispose of High Specific Activity, Low Level Radioactive Wastes from Three Mile Island Unit II," Sandia National Laboratories Energy Report, SAND-81-0567, TIC-098, WC-71 (April 1981).

TABLE 1. SYSTEM DESIGN REQUIREMENTS

Parameter/ Function	Design Requirement	Design Goal
Life	300 years	300 years
Vent	Prevent pressure buildup	0.052 mole/day
Lift provisions	Vertical load 3g	Factors of 3 on yield and 5 on ultimate
Stacking	Stack 6 high	265 kPa
Contour	Avoid water entrapment in voids/pockets	Smooth vertical sides, no pockets
Neutralizing agent	Permitted	Neutralize all corrosives by factor of 10
Decay heat	8 watts	--
Internal atmosphere	Saturated air with H ₂ , SO _x , CO, CO ₂ , NO ₂ , H ₂	--
Chloride content	2-200 ppm in free- standing liquid	--
pH	pH 2 to 11	Neutralized to pH 7 to 9; coating design requirement pH 6 to 10
Contact dose	Spec. estimate-- 20.00 Gy/hr	Internal coating = 32.76 Gy/hr; Seal = 4.43 Gy/hr
Becquerel deposition	80% of Bq in 0.54 m ³ at top	Uniform deposition over top 0.15 m of resin
Soil physicals	O ₂ = 3 mg/l; Cl = 0 to 300 ppm pH = 4 to 9; water = 0 to 100% sat. sulfates present	Eastern and western conditions separated
Burial depth	Up to 30 m	30-m burial depth capability in water-saturated soil

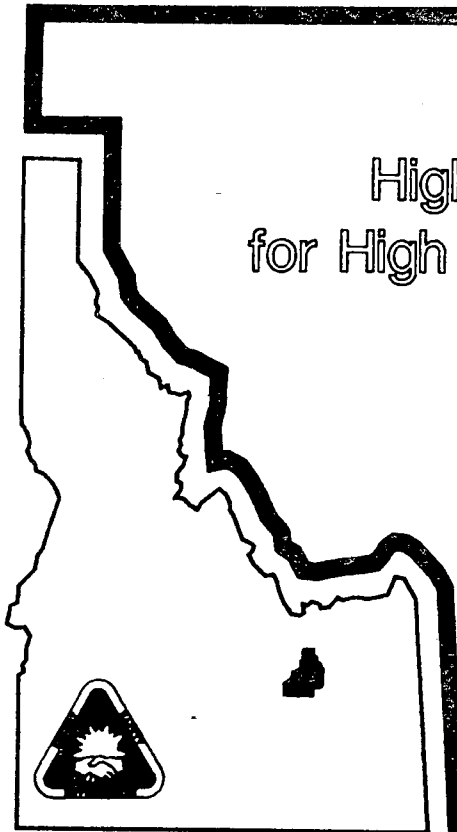

High-Integrity Container for High Specific Activity Wastes

ANS Winter Meeting
Washington, D.C.
November 14-18, 1982

presented by
R. L. Chapman



EPICOR-II Liner

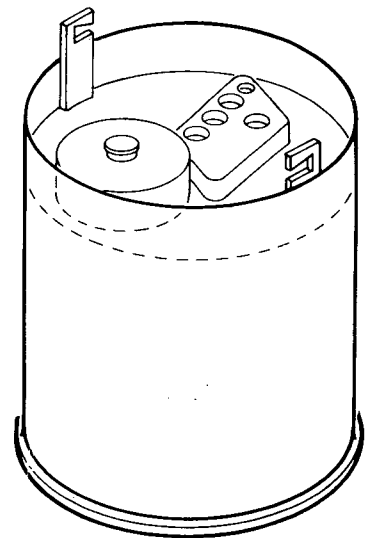
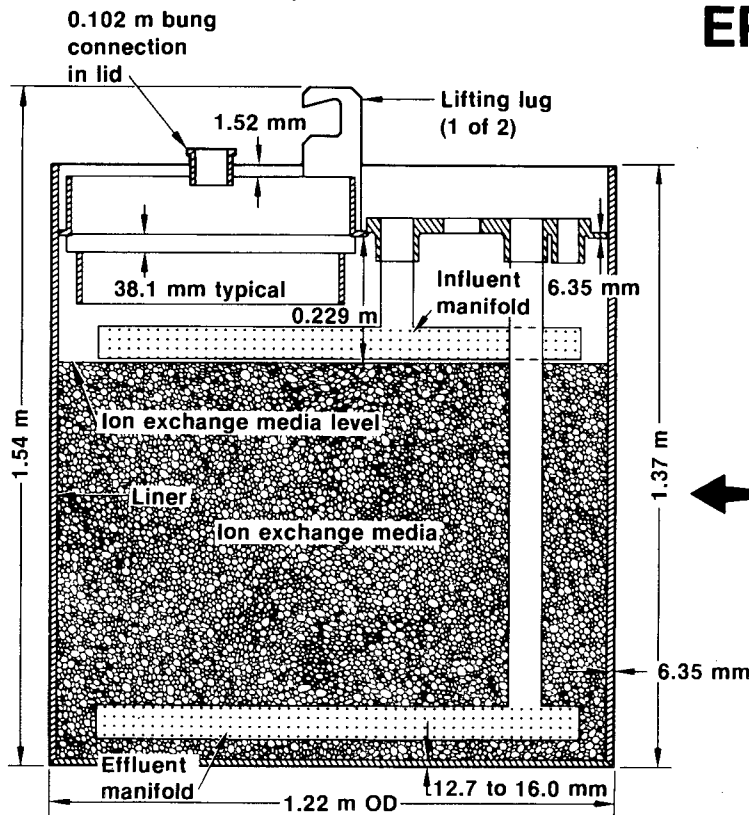

HIWDC Design Requirements

- Internal gas generation
 - Vent capacity sized for ≈ 0.052 moles/day (5 x best estimate)
 - Internal pressures
 - Vent function 10 psi
 - Structural capacity 25 psi
- Radiation dose to materials $\leq 1 \times 10^9$ rad γ & β
Varies with location

C2 0668

HIWDC Design Requirements (cont'd)

	<u>Maximum initial dose rate</u>	<u>Dose</u>
- Internal coating	3276 rad/hr	930 Mrad $\beta\gamma$
- Exterior coating	172 rad/hr	49 Mrad γ
- Vent	32 rad/hr	9 Mrad γ
- Seal	443 rad/hr	175 Mrad γ

C2 0669

Controlling Design Requirements/Environment

- Typical radioactive load
 - 1230 Ci Cs-137
 - 70 Ci Sr-90
 - 1275 $\mu\text{Ci}/\text{cm}^3$
 - Class "C" intruder waste per 10CFR61 (proposed)
- 300 year life
- Internal corrosion barrier
 - Chloride (0-200 ppm)
 - Gases (H_2 , SO_x , CH_4 , CO , CO_2 , NO_x)
 - pH 2-11

C2 0670

Controlling Design Requirements/Environment (cont'd)

- External corrosion resistance for:
 - Sulfates
 - Oxygen (0-3 mg/l)
 - Chlorides (0-300 ppm)
 - Water (0-100% saturation)
- External pressure combined 150 psi
- Lifting and handling with factors of 3 on yield;
5 on ultimate

C2 0671

High Integrity Container

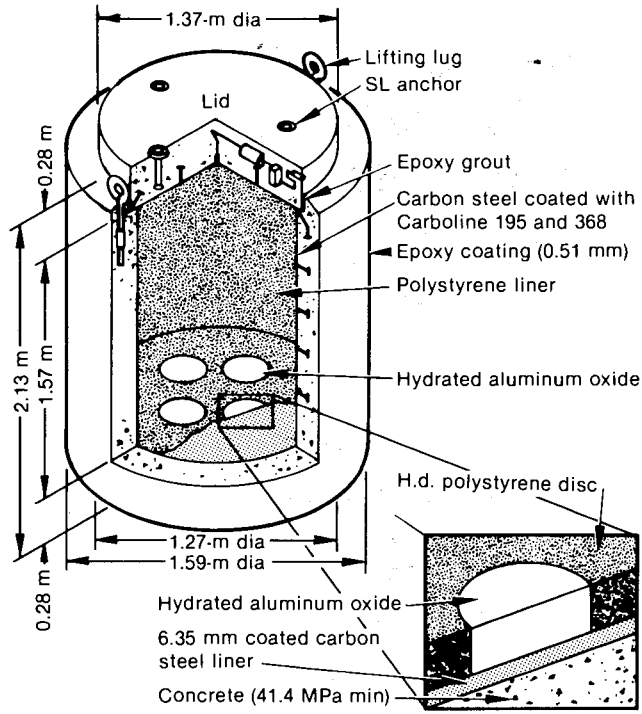

S2 3453

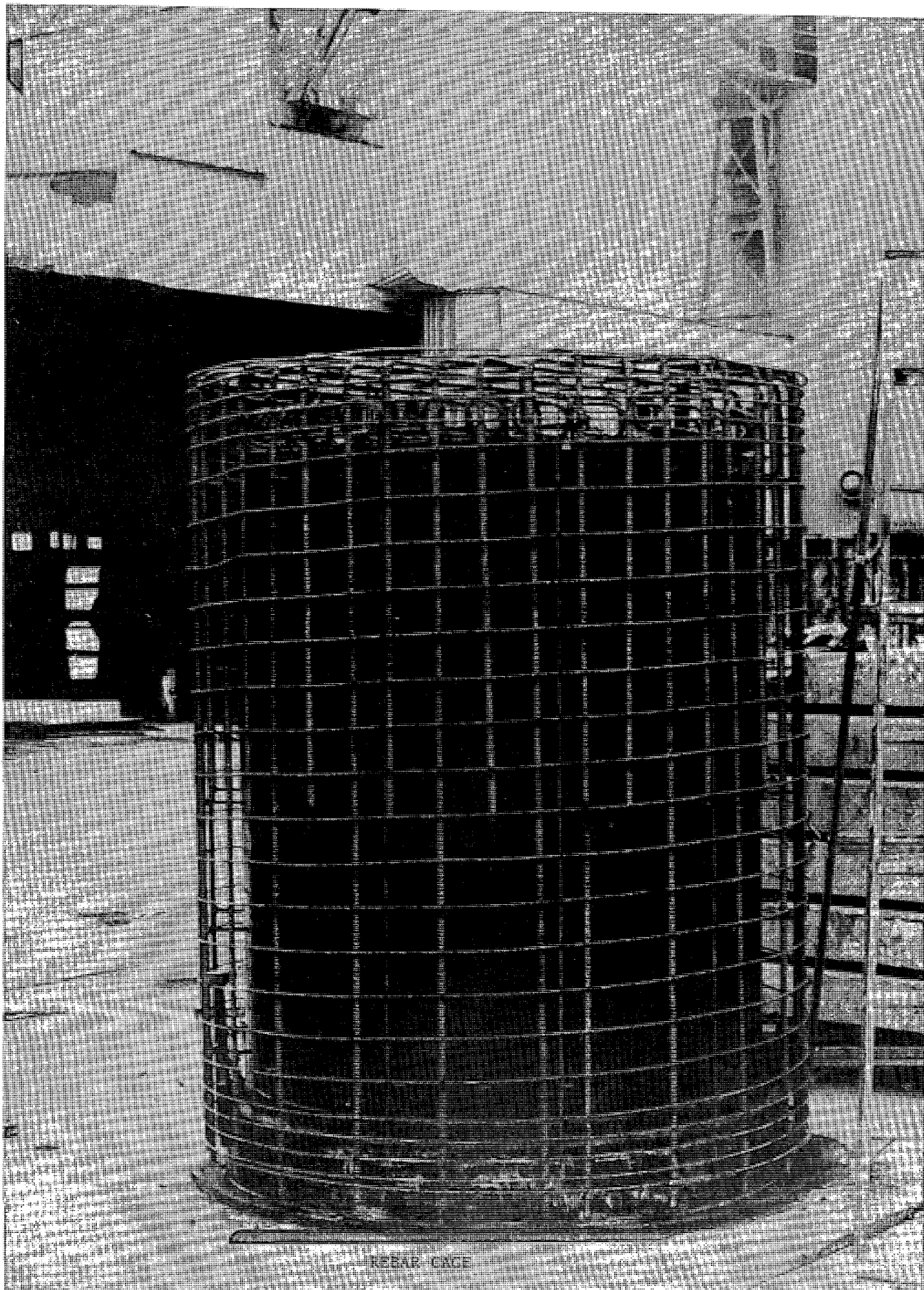

REBAR CYCLE

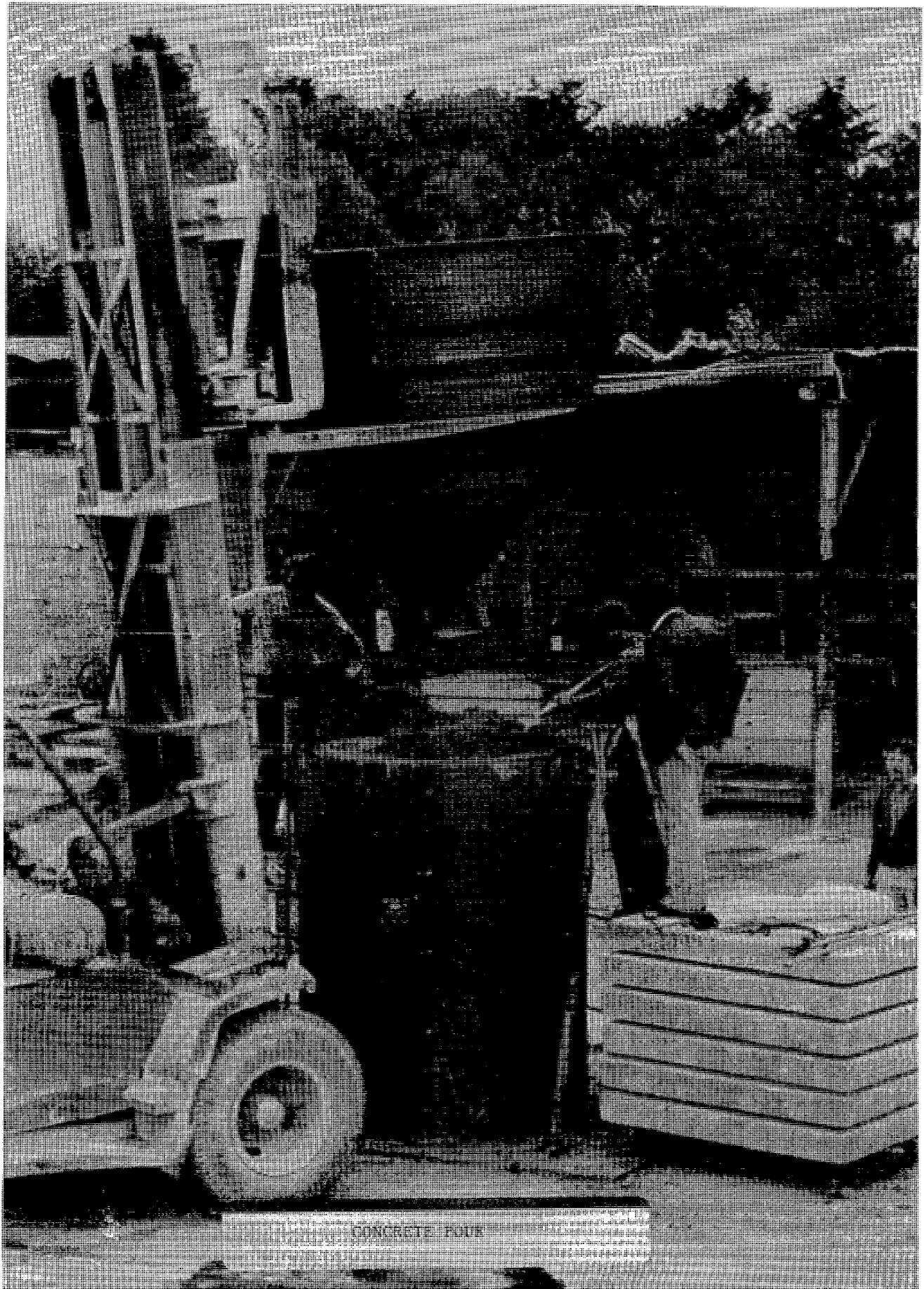

CONCRETE PIPE

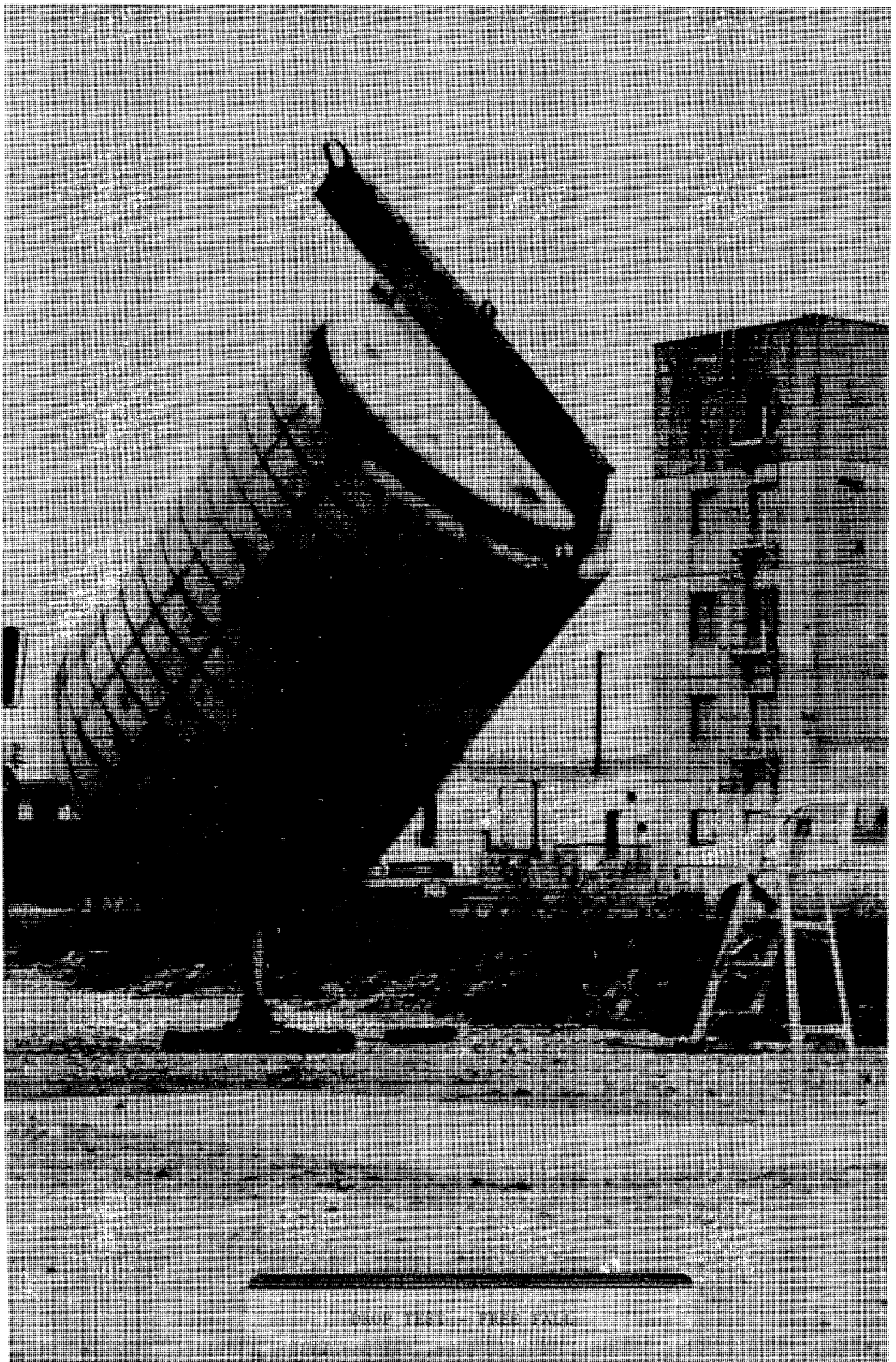

DROP TEST - FREE FALL



DROP TEST - CORNER IMPACT

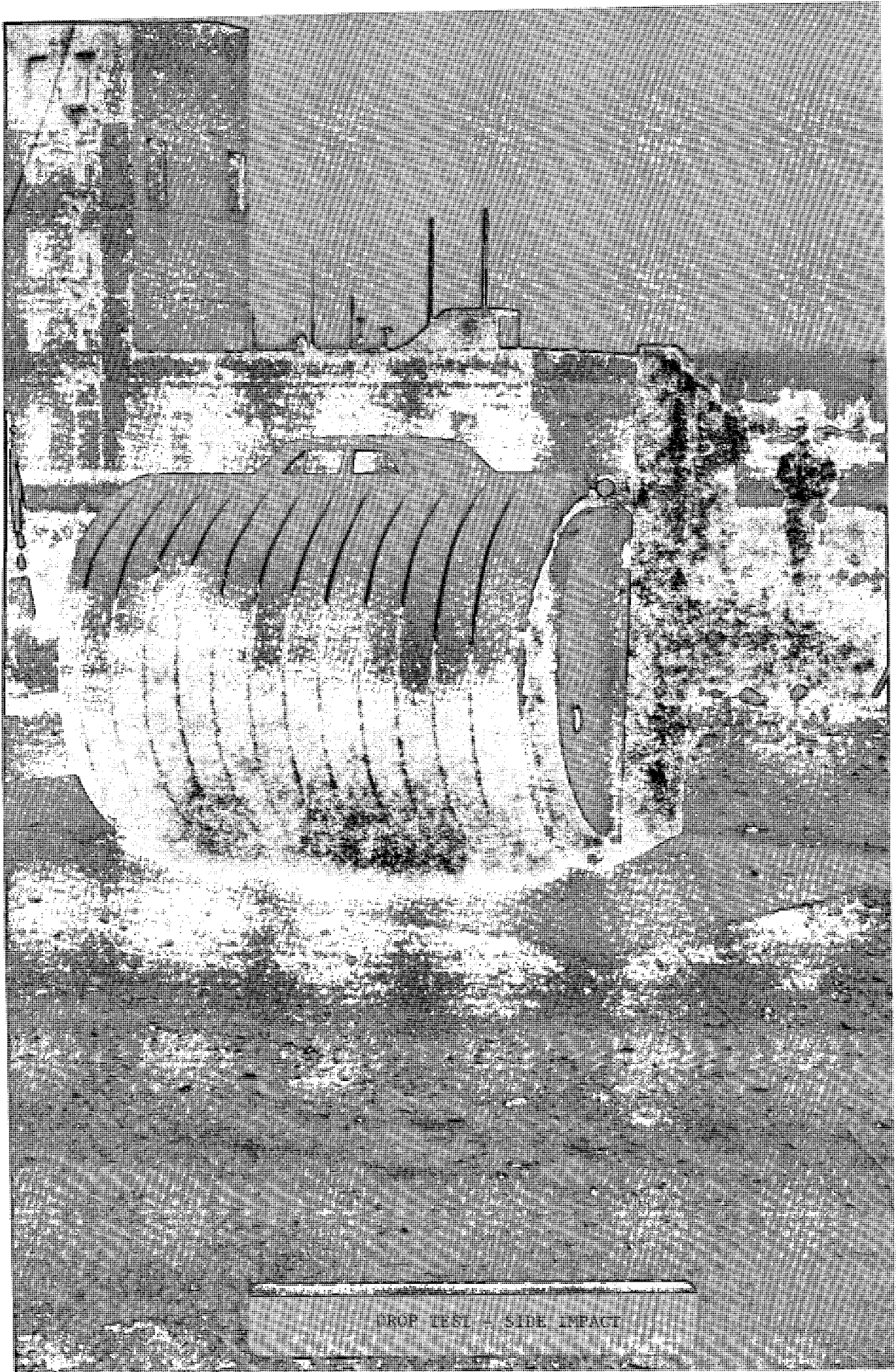

DROP TEST - SIDE IMPACT

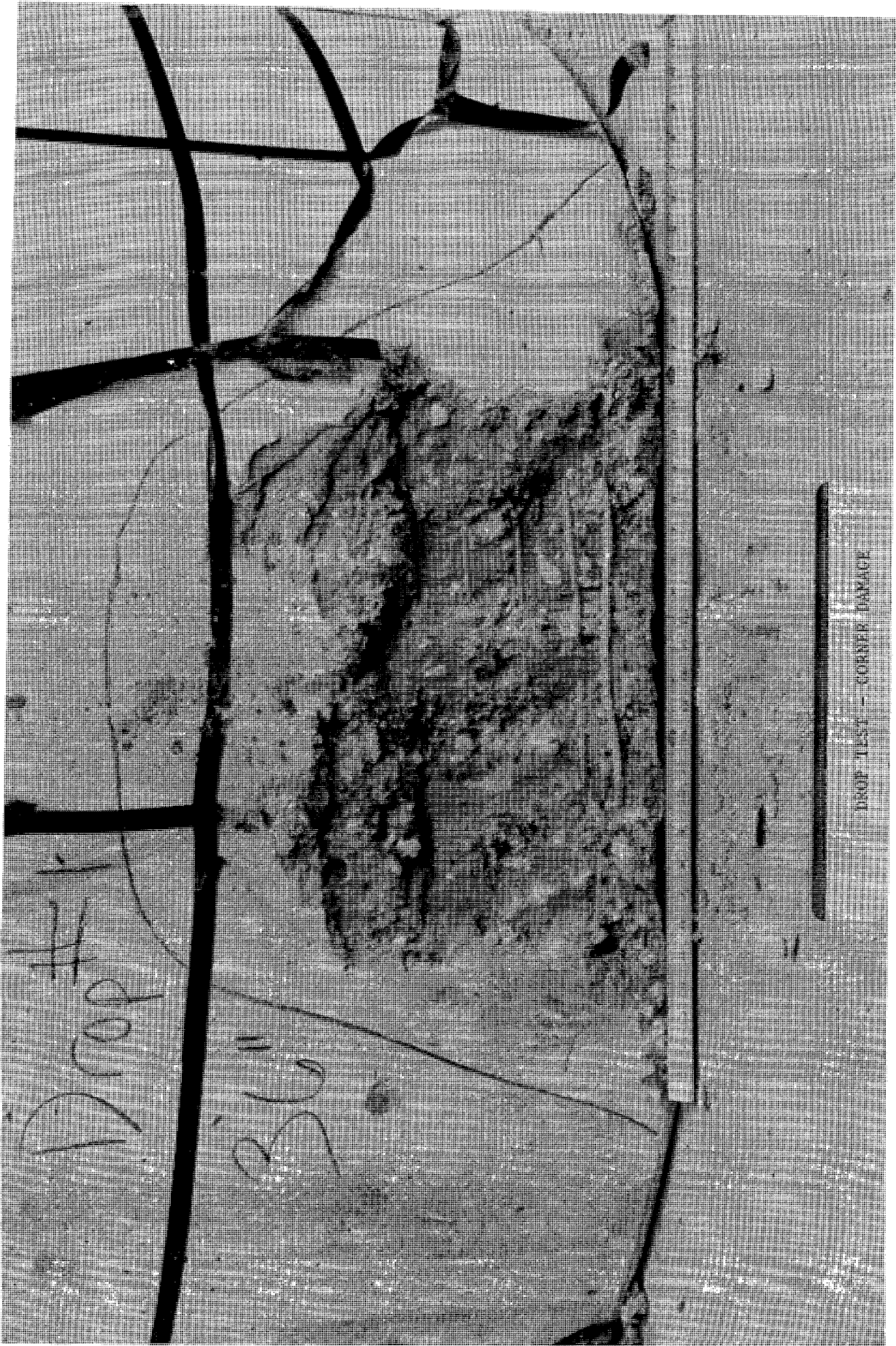

Drop #1

36"

DROP #1550 - CORNER DAMAGE

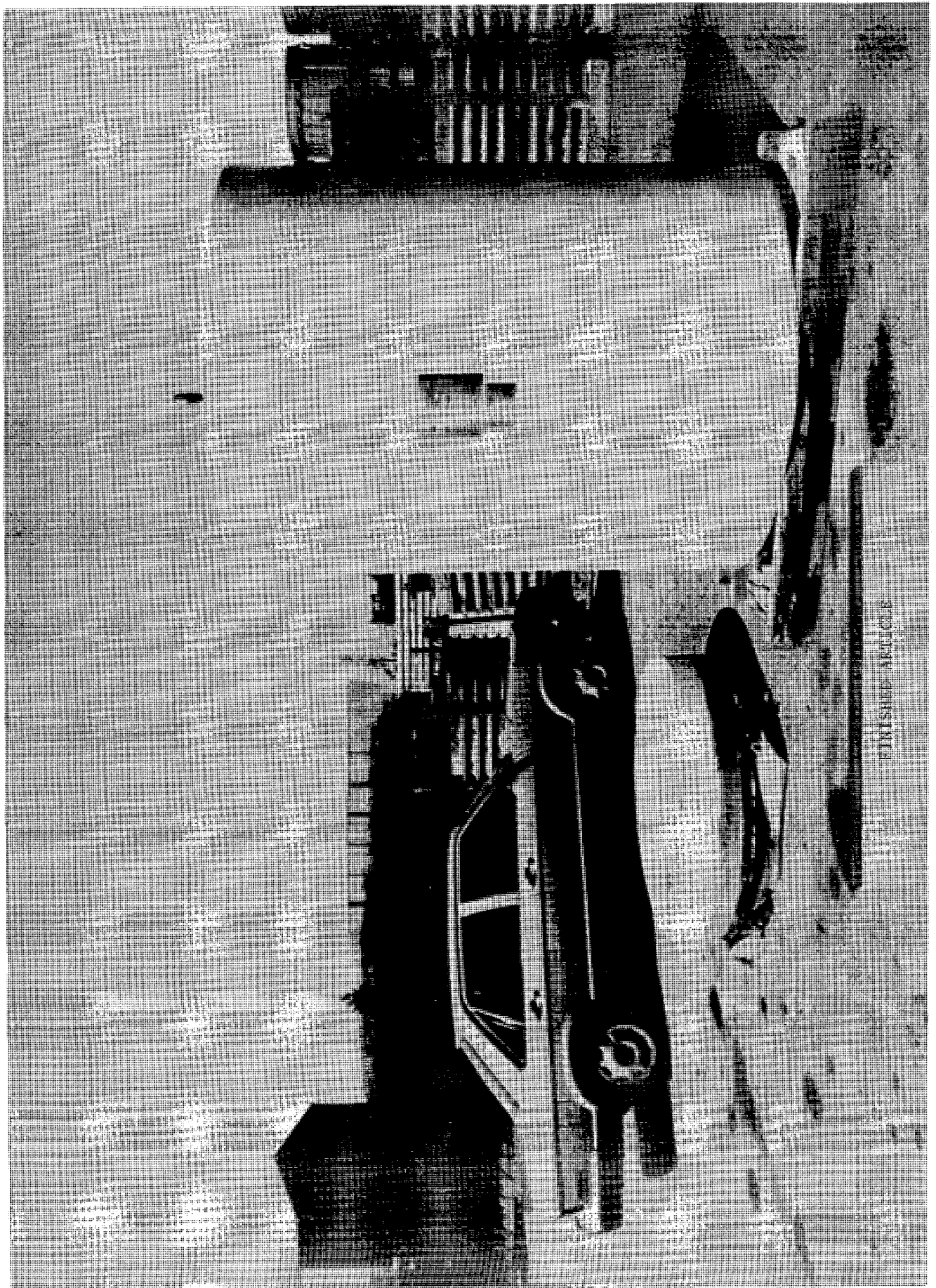

FINISHED ARTICLE



TMI-2 REACTOR BUILDING SUMP WATER
LEVEL MEASUREMENTS AND REMOVAL:
Ronald H. Greenwood (GPU Nuclear)

THE UNIVERSITY OF CHICAGO
LIBRARY

TMI-2

REACTOR BUILDING SUMP WATER
LEVEL MEASUREMENT AND REMOVAL

R. H. Greenwood

GPU Nuclear

Introduction

During the accident that occurred at TMI-2 on March 28, 1979, approximately 265,000 gallons of reactor coolant was discharged to the basement of the Reactor Building. After the accident, an additional 360,000 gallons of water was discharged to the basement from various sources. This resulted in a volume of water with a total depth of approximately 8½ feet. The water is referred to as the reactor building "sump water."

Monitoring of all in-leakage sources, water levels, and potential leak paths was initiated to assure the integrity of the Reactor Building. As of June 16, 1982, the water was removed, processed, and stored to be used for future cleaning of the Reactor Building.

Sump Water Level Measurement

The first sump water level measurements were taken 27 days after the accident by the use of a water pressure gauge installed on an 18 inch diameter emergency decay heat suction pipe from the Reactor Building sump. (See Figure 1 To assure that the contaminated water trapped in the pipe would move into the building during valve operation, an over-pressure of borated water from the borated water storage tank (BWST) was applied to outboard side of the outer

isolation valve. When the inner isolation valve was opened below the sump water, communication was established. This allowed measurements of total pressure to be obtained. These measurements, in conjunction with the reactor building air pressure gauge readings, provided the data to calculate the sump water depth. The sensitivity of the air and water pressure gauges along with the accuracy of locating the water pressure gauge reference level resulted in a calculated sump water depth to an accuracy of ± 3.0 inches.

Prior to these initial measurements, the water level was estimated from plant water inventories and the calculated reactor building volume. However, the first level measurements indicated a volume of the sump water greater than that calculated from inventories. Other systems that penetrate the reactor building were systematically surveyed to determine if they could cause additional in-leakage. It was found that the emergency river water cooling system was the only source that could not be monitored for in-leakage. Lifting of a reactor building cooler check valve, due to over-pressurization, was assumed to provide the potential in-leakage path. The cooling system was leak tested then reactivated and monitored closely to assure cooling water pressure remained within the operation limits. The rate of sump water level increases were determined by statistically averaging the daily readings. When more than three water level readings exceeded the standard deviation of previously measured data, investigations were made to evaluate the cause.

During August, 1979, a spare penetration located two feet above the water level was remotely drilled out (See Figure 2). A flexible tube was then inserted through the penetration and allowed to enter the contaminated water in the sump. As the tube was lowered, samples of sump water were drawn into shielded sample cylinders. These were analyzed to characterize the radioactivity of the sump water. The information was used to specify the design for the sump water cleanup system.

After this sampling operation, the same sample tube was used to monitor the water level. Water was flushed through the tube to eject any trapped air into the reactor building. Measurement of the vacuum needed to hold the water in the tube, above the sump water, gave a direct indication of sump level. This inverted manometer was used until January, 1982, when a continuous level readout using a bubbler system was installed.

Monitoring of sump water level changes provided assurance of the reactor building leak tight integrity. Known in-leakage from the reactor coolant system ranging from 0.1 gpm to 0.36 gpm or 0.02 to 0.07 inches per day, was compared to the accumulating sump water level. Since the accuracy of the inverted manometer readings were $\pm \frac{1}{2}$ inch (equivalent to ± 3000 gallons), a statistical treatment was required to monitor sump level trends.

In July of 1980, the first purging of the reactor building was performed to permit manned entries. The first direct observation and photograph of the water level was obtained during an entry on August 15, 1980. The picture showed that the water was just above a stair landing platform. The level of this platform could only be determined to be within construction tolerances. However, this level was within two inches of the inverted manometer measurement. This confirmed that there was not a large unknown systematic error in the inverted manometer sump water level measurements.

The reactor building was purged prior to each manned entry. The combination of this purging and the heated sump water permitted small amounts of water to be released in a purified vapor condition. The amount of water evaporated during purge was calculated and verified by the statistically treated water level measurements.

Sump Water Removal

In November of 1981, the first of the accumulated 600,000 gallons of sump water was removed for processing. This was accomplished using an assembly consisting of a conventional Goulds submersible sump pump attached to a polystyrene float (See Figure 3). The floatation allowed the pump to float on the sump surface and initially draw off the upper levels of water that had been clarified due to its inactivity for over two years. The float was designed such that it would initially float at an angle and then lie flat on its side as it approached the bottom. The final float configuration was wrapped with fiberglass cloth and epoxy to increase its strength and durability. The pump, float, attached flexible rubber discharge hose, and power cable were launched from a stairwell platform seven feet above the sump water. Quick disconnects were used to route additional hose to a reactor building penetration. Since this penetration lead directly into the fuel handling building, the routing of the highly contaminated water to the process area was simplified. All the piping installed outside of the reactor building was safety class to comply with the ASME Section III, Piping Codes. In addition, lead shielding was placed around the pipe along its route to minimize radiation exposures. The temporary equipment installed in the reactor building was not shielded nor was it safety grade because leaks resulting from its failure would be contained in the reactor building containment.

Batches of 30,000 gallons were removed, passed through sand filters located in the fuel pool, and stored for processing in tanks installed in the fuel pool. The floating pump was used until the water depth was reduced from 8.5 feet to 6.0 inches. At the 6.0 inch depth, the floating pump was no longer useful because it was laying on its side drawing air from the circumferential suction strainer around its midpoint.

In order to remove the remaining sump water, a domestic jet pump was then installed on the reactor building floor above the sump. The jet was lowered through a guide tube into the incore guide tube trench floor of the reactor building basement (See Figure 4). A jet pump was selected due to the lift limitations of suction pumps. The jet pump suction system was found to draw water down to a $\frac{1}{2}$ inch depth during mock up tests. The pump guide tube, which consisted of three sections of four inch diameter domestic plastic drain pipe, was inserted into the incore monitoring tube trench from the upper floor. The guide tube sections were threaded between the incore monitoring tubes and joined with tape as they were lowered into place. This rigid plastic guide tube permitted the flexible jet pump piping to reach the trench. The total installation required less than five minutes of exposure for two well rehearsed engineers.

The pump assembly was installed without a check valve so that the system could be backflushed after each operation. Priming the pump without a check valve before each operation was found to require a back flow rate in excess of 20 gpm. This criteria for starting the pump was determined from mock up operation of the system before it was installed.

As the water depth decreased to the floor level, the first of the two sand filters located in the fuel pool clogged. It was determined from the filter back pressure increase rate that the floor drain-down turbulated the sediment that had accumulated on the basement floor. The economics of replacing submerged sand filters led to the installation of a commercially available intermediate back-flushable sand filter in the reactor building with quick disconnects. This intermediate filter returns any collections of particulates to the reactor building basement for removal at a latter date.

This jet pump system, now installed and operating, also permits removal and reprocessing of the contaminated reactor building wash-down water.

The accident water which was processed by a demineralizer system submerged in the fuel pool is stored in onsite tanks. This same water is now being used as wash-down water for decontamination by hydro lasing. The wash water is returned to the sump via the reactor building drain system then again removed by the jet pump for reprocessing.

Summary

The use of conventional methods and commercially available equipment permitted the monitoring and removal of the contaminated water from the TMI-2 reactor building. Through unique applications of basic engineering principles, water levels were remotely monitored. Using "off the shelf equipment," innovative pumping systems were installed to first remove the clarified upper levels of sump water and then to remove the remaining sediment laden water.

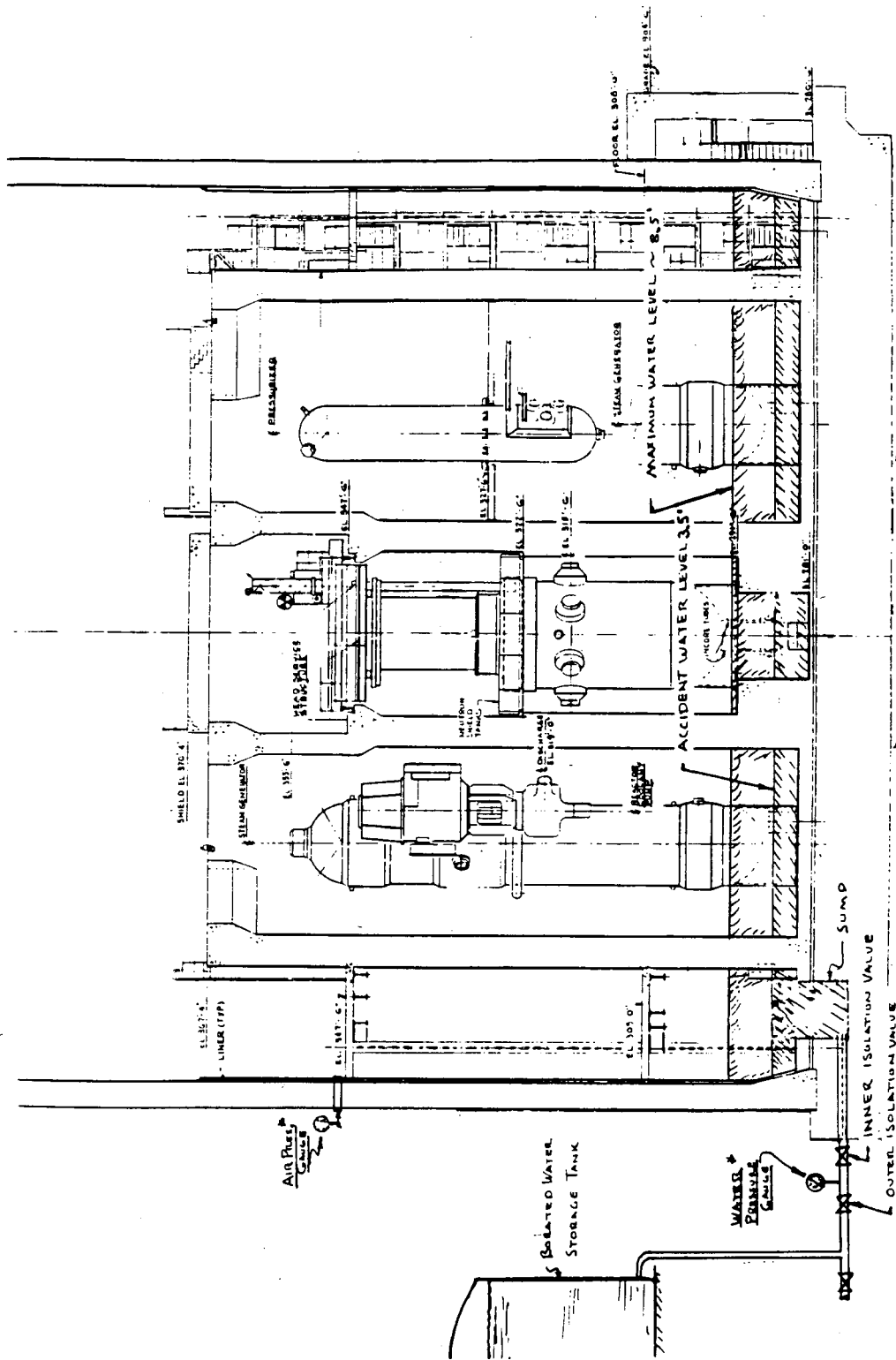

REACTOR BUILDING SECTION

SUMP WATER ACCUMULATION

FIGURE 1

* WATER LEVEL INDICATOR
INSTALLED APRIL 1979

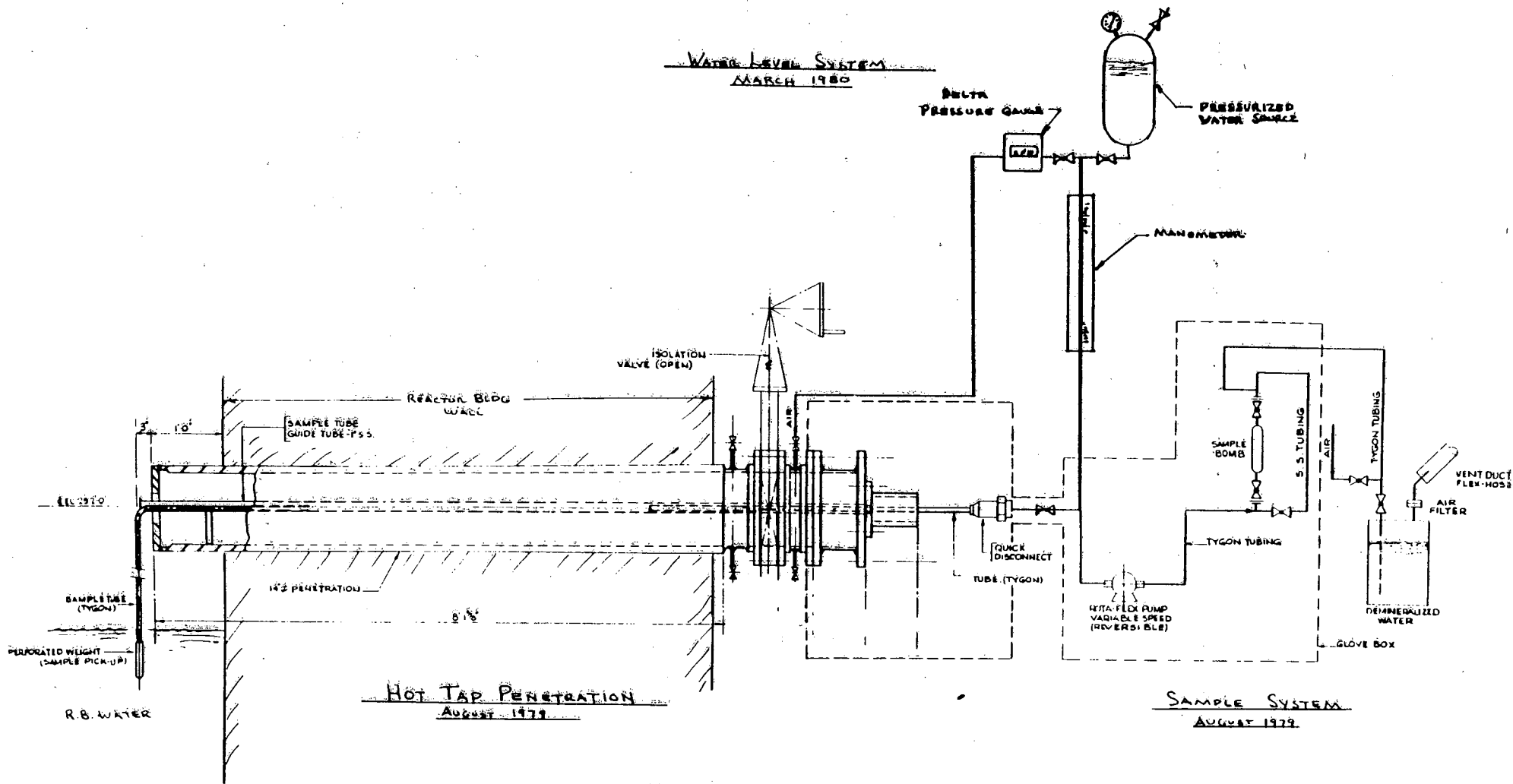

FIGURE 2

FLOATING PUMP
NOVEMBER 1961

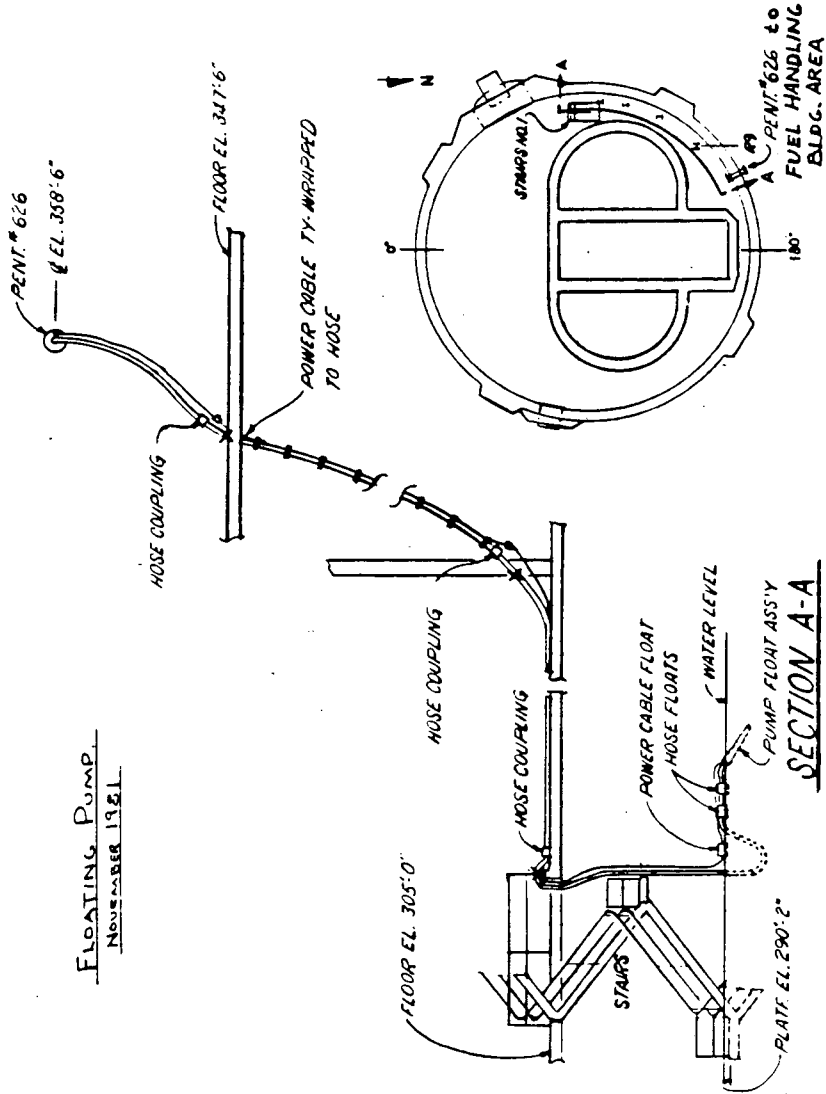

FIGURE 3

JET PUMP
APRIL 1982

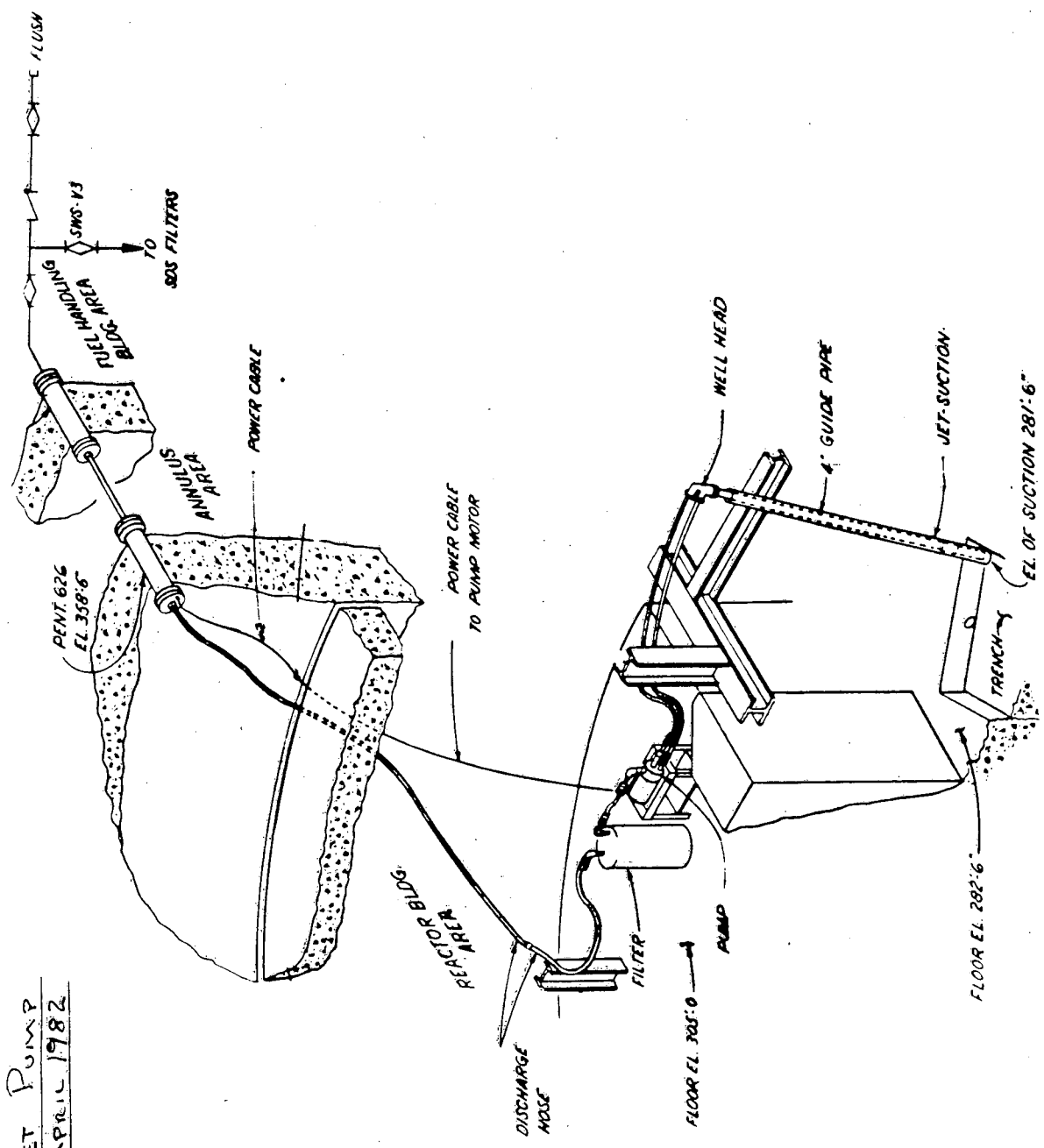

FIGURE 4

ZEOLITE PROCESSING OF THE TMI-2 REACTOR BUILDING SUMP
and Reactor Coolant System:
K. J. Hofstetter, C. G. Hitz (GPU Nuclear)

1944

Processing of the TMI-2
Reactor Building Sump and
the Reactor Coolant System

K. J. Hofstetter and C. G. Hitz
General Public Utilities Nuclear Corporation
P.O. Box 480
Middletown, Pa. 17057

As a result of the March 28, 1979 accident at the Three Mile Island Nuclear Station-Unit 2 (TMI-2), significant quantities of contaminated water were generated and stored in various locations in the reactor building and auxiliary buildings associated with the plant. Approximately 2300 m³ (600,000 gallons) of high level (> 100 µCi/ml) waste water was collected in the reactor building while approximately 340 m³ (90,000 gallons) of primary Reactor Coolant System (RCS) water was also contaminated to high activity levels.

In order to proceed with the decontamination of TMI-2, the Submerged Demineralizer System (SDS) was designed to process the highly contaminated water in the Reactor Containment Building (RCB) and the RCS.

Inorganic zeolites were chosen as the ion exchange media to be used in the SDS system. Their selection was based on the following criteria:

I. The ion exchange media must be extremely stable to ionizing radiation.

The water to be treated by the SDS system was highly contaminated, principally the long lived isotopes of Cs-137, and Sr-90. Many reports document the radiation instability of organic ion exchange resin. Total absorbed doses of 1×10^8 Rads have been shown to result in loss of functionality, gas generation and other dilatorious effects. Zeolites exposed to doses up to 1×10^{11} Rads have shown no loss of structure or functionality. Based

on the Cs-137 and Sr-90 concentrations in the highly contaminated water at TMI-2, activity loadings as high as 0.5 Ci/ml were projected (and achieved). This results in an integrated dose of $1 \times 10^{+10}$ - $1 \times 10^{+11}$ Rads to the zeolites.

II. The ion exchange media must be selective for the radioactive species in concentrated solutions of competing ions.

In addition to the radioactive contaminants of Cs-137 and Sr-90, high concentrations of chemicals were present in the RCB water and the RCS water. Sodium hydroxide released by the reactor building spray system early in the accident contributed to a sodium concentration of 1600 $\mu\text{g}/\text{ml}$ in the RCB water. Sodium hydroxide was added to the RCS for pH control at a level of 1000 $\mu\text{g}/\text{ml}$. Sodium competes with Cs and Sr for cation ion exchange sites. The high radioactive concentration of the Cs and Sr actually represents low chemical concentration (1-2 $\mu\text{g}/\text{ml}$ and less than 0.05 $\mu\text{g}/\text{ml}$ respectively). Therefore, an ion exchange medium with extremely high selectivity for the radionuclides was required. Two zeolites with this property were identified. The naturally occurring zeolite chabazite (sold commercially by Union Carbide as IONSIV-95) is highly selective for cesium. A synthetic zeolite, LINDE A was found to be highly selective for Sr-90. These two zeolites when mixed in the correct ratio selectively removed Cs and Sr in solutions with high sodium concentrations.

III. The ion exchange media must be compatible with the vitrification process.

After zeolites were identified as primary candidates for the SDS system, a program was sponsored by the DOE to demonstrate zeolite compatibility with the vitrification process. Bench scale tests carried out at the

Hanford, Washington facility confirmed zeolite compatibility.

Performance

Reactor Building Sump Water Processing

Processing of the original RCB water is complete. The overall SDS system processing performance is shown in Table I. These data show the average influent and effluent cesium and strontium concentrations after processing 2300 m³ of RCB water.

TABLE I.

SDS Effectiveness in Processing Reactor Building Sump Water

<u>Radionuclide</u>	<u>Influent</u> ($\mu\text{Ci/ml}$)	<u>Effluent</u> ($\mu\text{Ci/ml}$)	<u>Decontamination</u> <u>Factor</u>	<u>Curies</u> <u>Removed</u>
Cs-134	13.1	1.0E-4	1.3E+5	29,800
Cs-137	123	8.6E-4	1.4E+5	278,000
Sr-90	5.14	8.8E-3	5.9E+2	11,600
Sb-125	1.1E-2	1.1E-2	--	--
Ce-144	4E-4	4E-4	--	--
Co-60	2E-5	2E-5	--	--
			TOTAL	<u>319,400</u>

The nearly 320,000 curies of radioactivity removed from the sump was immobilized on 1550 Kg of 3:2 mixture of the IONSIV-95 and LINDE A zeolites. A volume reduction of approximately 1460 was achieved.

Reactor Coolant System Processing

It is expected that RCS processing will continue over several years to support various TMI-2 recovery tasks such as head removal and defueling. Because of the need to keep the core flooded, the RCS must be processed in a feed and bleed mode.

Prior to camera inspection of the core in July 1982, five batches of RCS water were processed by the SDS system. SDS performance during the clean-up of this 190 m³ of water are summarized in Table II.

TABLE II.

SDS Effectiveness in Processing Reactor Coolant System Water

<u>Batch Number</u>	<u>Radionuclide</u>	<u>Influent</u> ($\mu\text{Ci/ml}$)	<u>Effluent</u> ($\mu\text{Ci/ml}$)	<u>Curies Removed</u>
1	Cs-137	9.7	8.4E-4	1990
	Sr-90	9.5	4.7E-2	1940
2	Cs-137	6.7	8.0E-4	1280
	Sr-90	8.9	4.3E-2	1690
3	Cs-137	3.6	5.3E-4	712
	Sr-90	9.9	2.7E-2	1950
4	Cs-137	4.4	4.0E-4	840
	Sr-90	7.9	4.4E-2	1500
5	Cs-137	2.9	3.7E-4	550
	Sr-90	10	3.5E-2	1890

Because of the feed-bleed nature of the RCS processing, the SDS system is not as efficient as it was for RCB processing. However, a significant volume reduction factor is being achieved with decontamination still quite high by industry standards.

In summary, inorganic zeolites with their unique properties of radiation stability, chemical selectivity and solidification capability have contributed to the successful operation of the SDS at TMI-2. The continuing decontamination and recovery activities at TMI-2 will likely expand water processing technology as additional applications for zeolites using the SDS system are identified.

% BREAKTHROUGH (Sr^{90} , Cs^{137}) vs GALLONS PROCESSED
(3:2 RATIO)

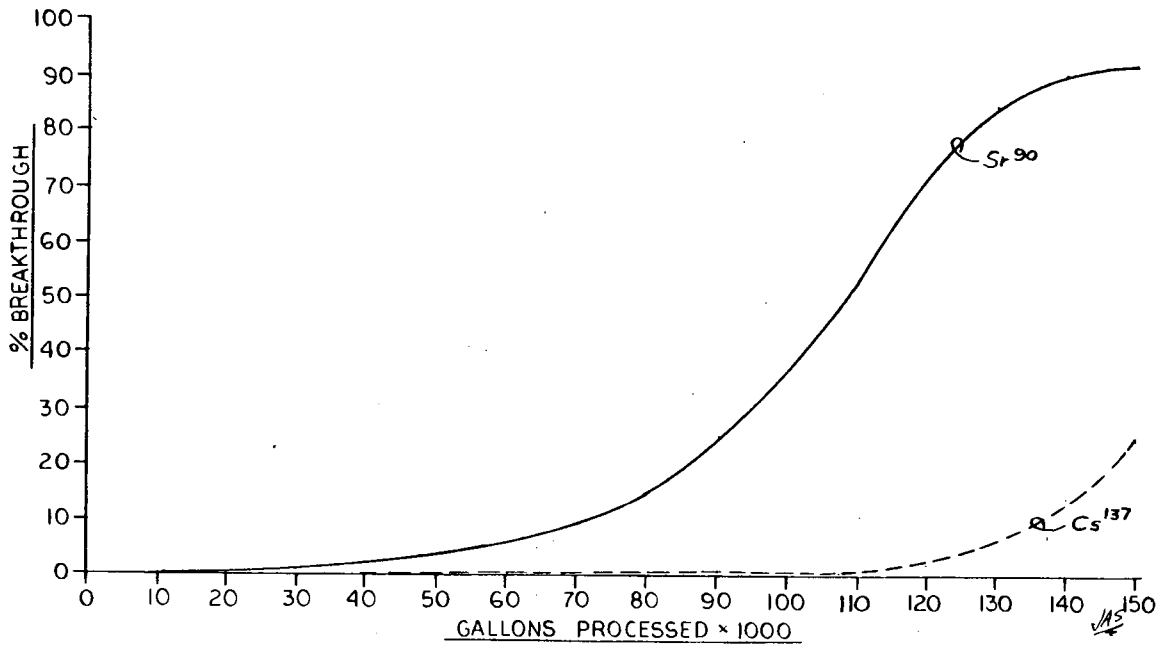

% BREAKTHROUGH (Sr^{90} , $Cs^{134+137}$) vs. GALLONS PROCESSED
(3:2 RATIO ; 1st CYCLE OF OPERATION)

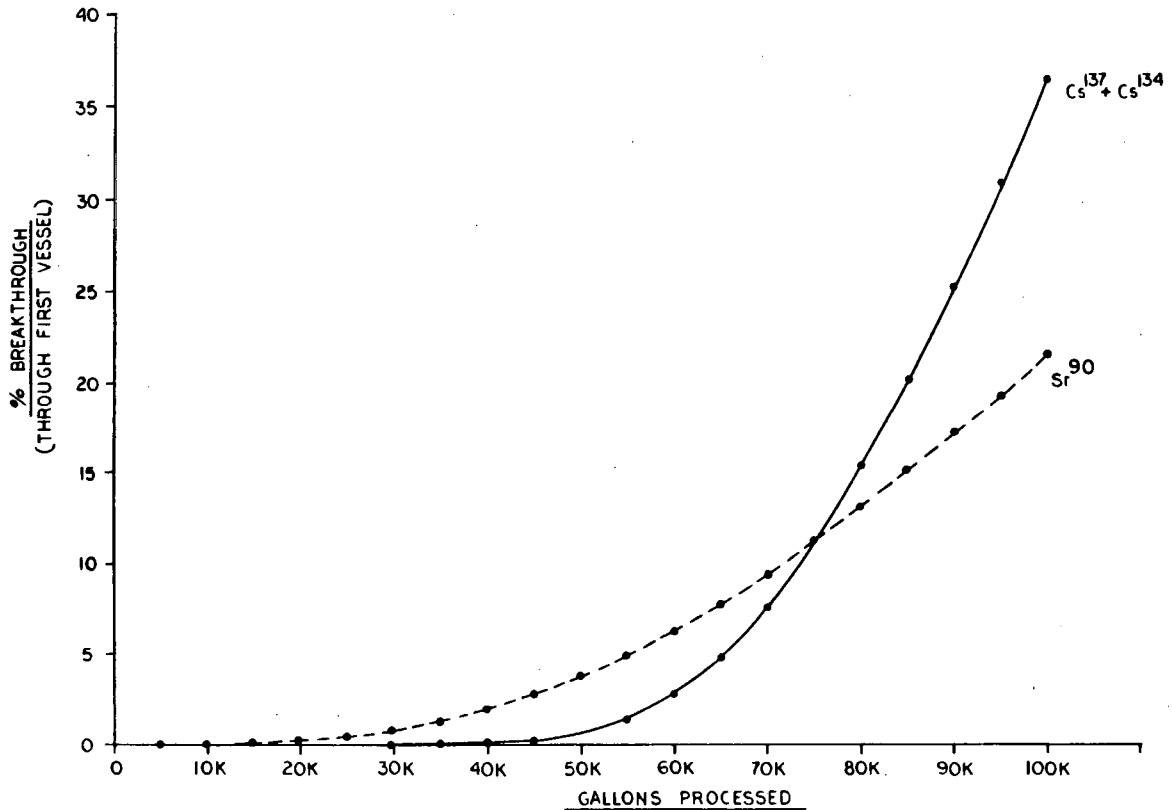

TMI-2 SUBMERGED DEMINERALIZER SYSTEM

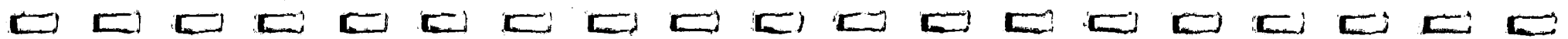
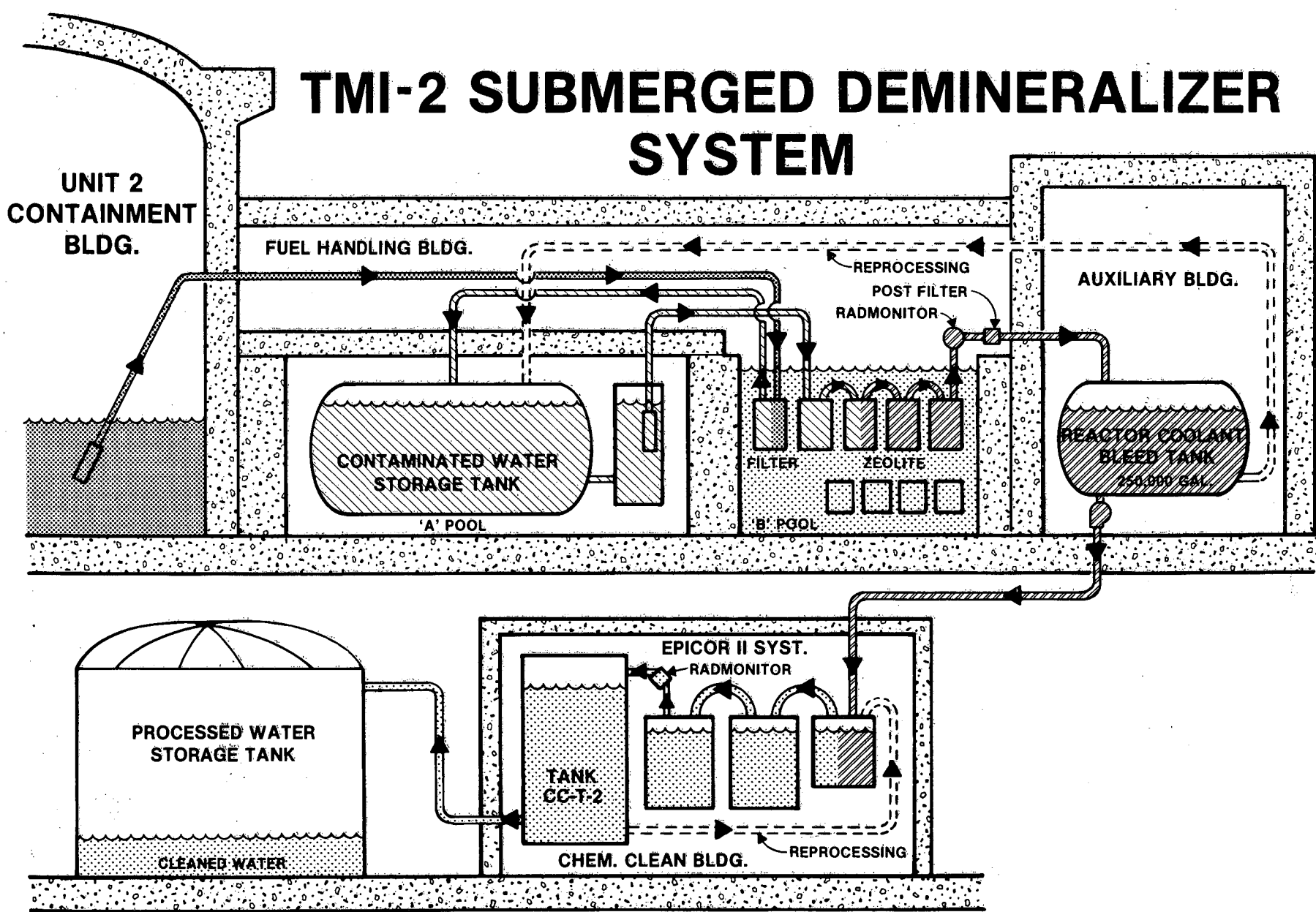

TABLE I

SDS EFFECTIVENESS IN PROCESSING REACTOR BUILDING SUMP WATER

<u>Radionuclide</u>	<u>Influent</u> ($\mu\text{Ci/ml}$)	<u>Effluent</u> ($\mu\text{Ci/ml}$)	<u>Decontamination</u> <u>Factor</u>	<u>Curies</u> <u>Removed</u>
Cs-134	13.1	1.0E-4	1.3E+5	29,800
Cs-137	123	8.6E-4	1.4E+5	278,000
Sr-90	5.14	8.8E-3	5.9E+2	11,600
Sb-125	1.1E-2	1.1E-2	--	
Ce-144	4E-4	4E-4	--	
Co-60	2E-5	2E-5	--	
			TOTAL	319,400

TABLE II

EPICOR-II PROCESSING OF SDS EFFLUENT

<u>Radionuclide</u>	<u>Influent</u> ($\mu\text{Ci/ml}$)	<u>Effluent</u> ($\mu\text{Ci/ml}$)	<u>Decontamination</u> <u>Factor</u>	<u>Curies</u> <u>Removed</u>	<u>Curies</u> <u>Remaining</u>
Cs-134	1.0E-4	<2E-7	500	0.23	4E-4
Cs-137	8.6E-4	3.2E-7	2,700	2.0	7E-4
Sr-90	8.8E-3	1.7E-5	500	19.9	3.9E-2
Sb-125	1.1E-2	<4E-7	27,500	24.9	9E-4
Ce-144	4E-4	<9.7E-7	400	0.9	3.2E-3
Co-60	2E-5	<2E-7	100	0.04	5E-4
		TOTAL (excluding TRITIUM)		47.97	4.5E-2
H-3	8.8E-1	8.8E-1	1		2000

TABLE III
ACTIVITIES IMMOBILIZED ON SDS ZEOLITES RCB PROCESSING

<u>Liner ID</u>	<u>Date</u>	<u>Sr-90</u>	<u>Curies Loaded</u>	
			<u>Cs-134</u>	<u>Cs-137</u>
D10011	11/28/81	2100	4450	41800
D10012	11/09/81	1930	5570	55000
D10013	01/10/82	2000	4800	46100
D10014	03/05/82	730	29	300
D10016	03/05/82	1890	5660	52600
D10017	10/04/81	1040	2890	28800
D20027	03/05/82	67	0.04	0.5
D20028	02/09/82	1680	4130	40150
D20029	03/05/82	3	0.006	0.08

SDS Effectiveness in Processing Reactor Coolant System Water

<u>Batch Number</u>	<u>Radionuclide</u>	<u>Influent</u> ($\mu\text{Ci}/\text{ml}$)	<u>Effluent</u> ($\mu\text{Ci}/\text{ml}$)	<u>Curies Removed</u>
1	Cs-137	9.7	8.4E-4	1990
	Sr-90	9.5	4.7E-2	1940
2	Cs-137	6.7	8.0E-4	1280
	Sr-90	8.9	4.3E-2	1690
3	Cs-137	3.6	5.3E-4	712
	Sr-90	9.9	2.7E-2	1950
4	Cs-137	4.4	4.0E-4	840
	Sr-90	7.9	4.4E-2	1500
5	Cs-137	2.9	3.7E-4	550
	Sr-90	10	3.5E-2	1890

CONTROLS OF RADIOLYTIC GASES IN LINERS OF RADIOACTIVE ZEOLITES:

J. Greenborg (GPU Nuclear),
J. O. Henrie (Richland Hanford Operations),
G. J. Quinn (EG&G Idaho, Inc.)

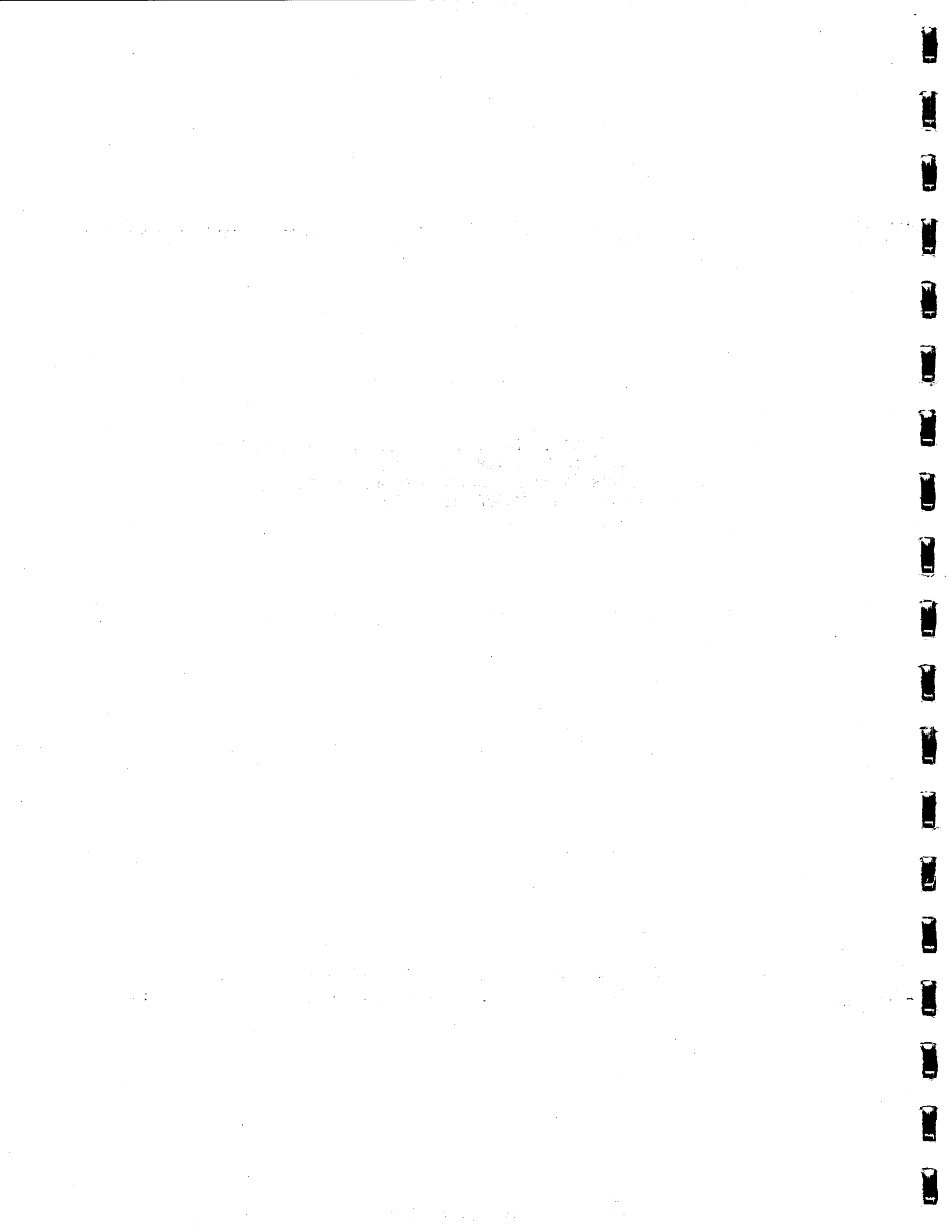

CONTROL OF RADIOLYTIC GASES IN LINERS OF RADIOACTIVE ZEOLITES*

J. Greenborg, General Public Utilities

J. O. Henrie, Rockwell Hanford Operations

G. J. Quinn, EG&G Idaho, Inc.

Early in the design evolution for the SDS demineralizer vessels (liners) at TMI-2, it was recognized that the production of gases due to the radiolytic decomposition of water in the liners would present a safety concern for in-plant storage, shipping, and disposal. Radiolytic gases were encountered during preparations to ship highly loaded zeolites to Pacific Northwest Laboratories (PNL) for vitrification R&D studies. Table 1 shows the estimated becquerel loadings of the seven liners first expended during SDS processing.

Data in the literature were not sufficient to predict the gas composition, generation rate, or final pressure on the liner with any degree of confidence. Therefore, a program was initiated to characterize the gas generation for each SDS demineralizer liner.

SDS liners have been tested in dewatered and non-dewatered states. To dewater, the free water in the SDS liner is forced out with nitrogen gas. Gas pressure rise and the void volume of the vessel are determined after the demineralizer vessel has been connected to the sampling system. Periodic samples drawn via the sample cylinders are used to determine the gas composition. Table 2 shows the composition and pressure of gas sampled from SDS Liner D10015 before and after shipment from TMI-2 to PNL.

The following observations have been drawn from the gas generation rate data collected in the program:

* Work supported by the U.S. Department of Energy, Assistant Secretary of Nuclear Energy, Office of Coordination and Special Projects, under DOE Contract No. DE-AC07-76ID01570.

- o The gas generation rate is approximately proportional to the becquerel loading
- o The gas generation rate is proportional to the amount of water in the demineralizer vessel.

In consultation with General Public Utilities, various DOE experts reviewed the available technical options for solving the gas generation problem. The possible solutions identified include the following:

- o Shipment of liners in a cask of sufficient volume to safely store the generated gases
- o Self-drying by radiolysis, which would probably require 8 years to reduce the water content to a level considered safe for shipping
- o Purging or elution drying, using gases such as CO and CO₂
- o Suppression of radiolysis in a water-filled SDS liner by adjusting the water to an alkaline pH by the addition of ammonia or hydrogen
- o Vacuum drying, with the assistance of the self-heating of radioactive decay
- o Catalytic gas recombining in combination with vacuum drying.

Catalytic recombiner-vacuum outgassing was selected to maintain the radiolytic gases at safe levels for shipment.

A DOE-sponsored R&D program was initiated at Rockwell Hanford Operations and at Westinghouse Hanford Engineering Development Laboratories to define the optimum conditions for the use of an aluminum oxide coated with palladium-platinum as catalyst. A catalyst volume of 130 cc was effective in controlling and recombining H₂/O₂ gases at test rates of 3000 cc (STP) per hour.

Placing the catalyst inside the 0.28 m³ zeolite containers is performed remotely. Tests show the catalyst to be effective during both normal and upset conditions.

Methods were also developed for testing and demonstrating compliance with the federal transportation requirements for combustible gases.

TABLE 1. ESTIMATED BECQUEREL LOADINGS OF THE FIRST SEVEN LINERS OF SDS ZEOLITE EXPENDED AT THREE MILE ISLAND

Liner	Water Type	Becquerel Loading x 10			
		Cs (134 + 137)	Sr	Total Cs + Sr	Total w/ Daughters
D10015	Bleed tank	2.13	0.37	2.50	4.77
D10017	Sump water	11.22	0.38	11.60	22.03
D10012	Sump water	20.14	0.57	20.71	39.27
D10011	Sump water	15.14	0.65	15.79	30.01
D10013	Sump water	13.71	0.37	14.08	26.76
D20028	Sump water	16.03	0.61	16.64	31.94
D10016	Sump water	19.95	0.59	20.54	39.37

TABLE 2. COMPOSITION AND PRESSURE OF GAS SAMPLED FROM SDS LINER D10015 BEFORE AND AFTER SHIPMENT

Time of Gas Sampling	Pressure (kPa)	Composition (%)			
		Hydrogen	Nitrogen	Oxygen	Carbon Dioxide
Before shipment (5/17/82)	13.97	0.0	100.0	0.00	--
After shipment (5/26/82)	25.51	5.6	93.8	0.05	0.55

(Paper received too late for proper placement)

CHEMICAL DECONTAMINATION METHODS
APPLICABLE TO THE TMI-2 RCS:

C. J. Card, J. R. Divine, L. F. Munson, M. D. Naughton
(Electric Power Research Institute)

1945

Chemical Decontamination Methods
Applicable to the TMI-2 RCS

C. J. Card
J. R. Divine
L. F. Munson
M. D. Naughton - EPRI

October 1982

Prepared for
Electric Power Research Institute
Under Contract 2311204906

To be Presented at the
Winter Meeting
American Nuclear Society
Washington, D.C.
November 14, 1982

Battelle
Pacific Northwest Laboratories
Richland, Washington 99352



CHEMICAL DECONTAMINATION METHODS
APPLICABLE TO TMI-2

C. J. Card, J. R. Divine, L. F. Munson, M. D. Naughton

In 1981 the Electric Power Research Institute initiated a number of studies on decontamination of reactor coolant systems after an accident involving fuel failure. The emphasis of the studies was to be generic but specific guidance for TMI-2 was to be provided also.

One part of the overall program was to evaluate previously used chemical decontamination processes as well as potentially useful new processes for possible use in accident recovery.^(1,2) A group of fourteen processes or types of processes were selected for review. Of these, seven have been used previously for fuel debris or fission product removal. The remaining seven processes are new processes developed specifically for corrosion product removal. Each process was then reviewed with respect to its:

- Technical description - chemical composition and general operating conditions,
- Past usage - types of situations where used including whether used to remove fuel debris, fission products, or corrosion products,
- Effectiveness - how well contamination is removed, with decontamination factors where available,
- Process limits - upper or lower limits of pressure, temperature or composition if given or predictable,
- Safety - information on fire, chemical, and health aspects of preparing and handling the chemicals and their solutions,
- Waste management - a review of possible methods of waste concentration and solidification,

- Applicability to TMI-2 - mainly a review of known corrosion behavior on the materials in the TMI-2 reactor coolant system and other limitations as described in the above areas, and
- Further development - general commentary on technical areas that need development prior to use.

Following the review, the processes were evaluated against a previously established set of criteria. The criteria consist of two subsets, prerequisites and a weighted quantitative set. In the prerequisites, any one of the criteria can eliminate the process; these criteria are objective in nature. Application of the criteria did, however, require some professional judgment because of the lack of quantitative data on some processes. Because of the way the initial selection of the processes was performed, there were no processes studied that definitely failed any of the prerequisites. There was, however, a substantial doubt regarding the ability of some of the processes to meet some of the prerequisites, in particular, the criteria on the effectiveness of uranium dioxide fuel and fission product removal. Ultimately the processes were grouped into three categories: Proven UO_2 and fission product decontamination agents; probable UO_2 and fission product decontamination agents, and questionable UO_2 and fission product decontamination agents.

The processes were then evaluated against the quantitative criteria. Quantitative criteria should be given weights by the reactor operator and are, therefore, reactor specific and somewhat more subjective than the prerequisites. The evaluation performed for this report assumed a reasonable set of weights although not necessarily those that might be representative of TMI-2. A range of weights was used to accommodate uncertainties in the available knowledge of the processes, Figure 1.

Based on the weights selected, the Can Decon process had the highest average score (uncertainties averaged numerically), Figure 1. It also had the narrowest range of uncertainty in the process application parameters. However, it fell into the group of processes with questionable effectiveness on uranium dioxide fuel and fission products. It is, therefore, our recommendation that it be tested in the laboratory for effectiveness. The second

highest ranking decontamination process was the class of processes, peroxide plus acid. This group had the greatest overall uncertainty regarding process application parameters, in part because it is a class of compounds, and in part because there are not well documented studies of its application. It is a member of the group of probably effective uranium dioxide fuel and fission product decontamination agents. A specific peroxide plus acid formulation evaluated separately, oxalic acid, hydrogen peroxide, and gluconic acid (OPG) ranked next and is a proven uranium dioxide fuel and fission product decontamination agent. Based on this evaluation, it is our recommendation that if Can Decon fails to be effective or is discarded for other reasons, a major development effort be directed at developing an OPG process that is effective, has acceptable corrosion behavior, and exhibits acceptable waste treatment characteristics.

The lowest ranking process was based on the use of concentrated mineral acids, in part because of operating difficulties but mainly because of large waste volumes.

References

1. Card, C. J., October 1982. "Post Accident Decontamination of Reactor Primary Systems and Test Loops," RP-2012-1, Topical Report, Prepared for Electric Power Research Institute by Battelle, Pacific Northwest Laboratories, Richland, Washington.
2. Munson, L. F., C. J. Card and J. R. Divine, October 1982. "An Assessment of Chemical Processes for the Decontamination of Reactor Coolant Systems," RP-2012-01, Final Report, Prepared for Electric Power Research Institute by Battelle, Pacific Northwest Laboratories, Richland, Washington.

Figure 1.
RANKING OF DECONTAMINATION PROCESSES
RELATIVE TO QUANTATIVE SELECTION CRITERIA

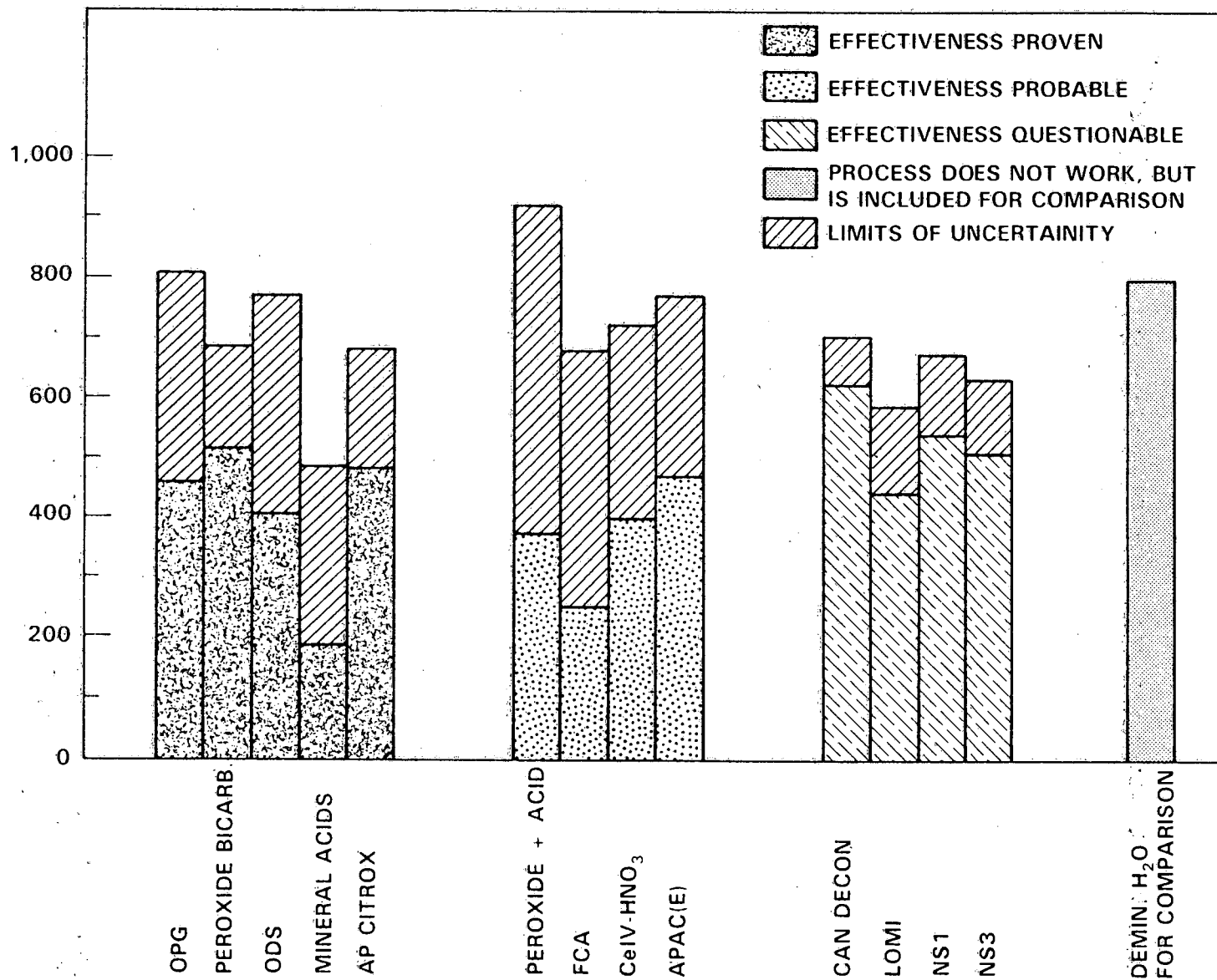

CHEMICAL DECONTAMINATION METHODS APPLICABLE TO THE TMI-2 RCS

**J.R. Divine, PNL
L.F. Munson, PNL
C.J. Card, PNL
M.D. Naughton, EPRI**



Battelle

Pacific Northwest Laboratories

OBJECTIVES

**TO PROVIDE A TECHNICAL REVIEW OF POTENTIAL PROCESSES AND
TO EVALUATE THE PROCESSES ON THE BASES OF A DEFINED SET
OF CRITERIA**

PROCESSES REVIEWED

- OXALIC-PEROXIDE-GLUCONIC (OPG)
- PEROXIDE PLUS ACID
- PEROXIDE-BICARBONATE (PBC)
- ALKALINE-TARTRATE-PEROXIDE (ATP)
- OXIDIZING DECONTAMINATION SOLUTION (ODS)
- FILM CONDITIONING AGENT (FCA)
- MINERAL ACIDS
- CAN-DECON
- L.O.M.I.
- CERIUM (IV)-NITRIC ACID
- AP-CITROX
- AP-AC/AP-ACE
- NS-1
- NS-3

METHOD

- PERFORM REVIEW USING PROPOSED OUTLINE
- ESTABLISH A SET OF EVALUATION CRITERIA
- EVALUATE EACH PROCESS

REVIEW OUTLINE

- TECHNICAL DESCRIPTION
- PAST USAGE
- EFFECTIVENESS
- LIMITATIONS
- SAFETY
- WASTE MANAGEMENT
- APPLICABILITY TO TMI-2
- DEVELOPMENT AND DEMONSTRATION NEEDS

EVALUATION CRITERIA

- PREREQUISITES - ABSOLUTE
- QUANTITATIVE - WEIGHTED

PREREQUISITES

- CAN REDUCE DOSE RATES BY MOBILIZING FISSION PRODUCTS OR FUEL DEBRIS
- RISK MUST BE NO WORSE THAN REACTOR OPERATION
- WASTE MUST BE DISPOSABLE
- NON-REPLACEABLE COMPONENTS WILL NOT LOSE MORE THAN 50% OF THE CORROSION ALLOWANCE
- NO CATASTROPHIC CORROSION

QUANTITATIVE

- EFFECTIVENESS AND AVAILABLE INFORMATION
- OPERATIONS
- WASTE MANAGEMENT
- HEALTH AND SAFETY

EFFECTIVENESS AND AVAILABLE INFORMATION

- DEMONSTRATED EFFECTIVENESS FOR URANIUM OXIDE 100 pts
- DEMONSTRATED EFFECTIVENESS FOR FISSION PRODUCTS 100 pts
- DEMONSTRATED EFFECTIVENESS FOR Zr COMPOUNDS
- EFFECTIVE AT CORROSION PRODUCT REMOVAL 30 pts
- MINIMUM DEVELOPMENT WORK NEEDED 100 pts

OPERATIONS

- MINIMAL CORROSION OF REPLACEABLE PARTS 30 pts
- LOW RISK FROM ACCIDENTS OR UPSETS 100 pts
- MINIMUM ADDITIONAL HEAT 50 pts
- MINIMUM TIME REQUIREMENTS 50 pts
- MINIMUM QUANTITY OF CHEMICALS 30 pts
- MINIMUM OF CONTROL DURING PROCESS 30 pts
- MINIMUM REPASSIVATION 50 pts

WASTE MANAGEMENT

- SMALL QUANTITY OF LIQUID WASTE 100 pts
- LIQUID WASTE READILY SOLIDIFIED 100 pts
- MINIMUM SOLID WASTE 100 pts

HEALTH AND SAFETY

- MINIMUM HEALTH PROBLEMS 20 pts
- LOW FIRE RISK 20 pts
- CONTROLLED DISSOLUTION RATE FOR CONTAMINATION 20 pts